



# PIATTO DOCCIA

Piatto doccia e piletta di ceramica, di spessore sottilissimo, h cm 3, realizzabile completamente su misura.

Super thin ceramic shower tray and drain, h cm 3, cut to measure.

sabbia  
sand/

ottanio  
ottanio/

nero  
black/

nero mat  
black matt/

bianco  
white/

bianco mat  
white matt/

PILETTA

Piletta di scarico realizzata in ceramica.

Ceramic drain.



SU MISURA

Piatto doccia tagliato a misura

Cut to measure shower tray.

3 cm

80 cm



80 cm

90 cm

100 cm

120 cm

140 cm

160 cm

ADATTABILITÀ  
/ Adaptability



Vasta gamma di piatti doccia realizzati in più formati.

A wide range of shower tray made in several sizes.

COLORI  
/ Colours

 **HIGHERGLAZE**

Innovativo smalto applicato sulla ceramica direttamente in fase di cottura. La superficie risulta essere perfettamente liscia non permettendo allo sporco e al calcare di depositarsi. Questo garantisce durevole brillantezza, piacevolezza al tatto, alta protezione da graffi, abrasioni ed agenti esterni.

Innovative enamel applied directly on the ceramic during firing. The surface appears to be perfectly smooth, not allowing dirt and limestone to settle. This ensures durable brilliance, pleasing to the touch, high protection from scratches, abrasions and from external agents.



**Idrorepellente:** l'acqua scivola velocemente sulla superficie.

Water-repellent: Water slides fast on the surface.



**IDROREPELENTE**

**LEVIGATO**

La superficie risulta essere perfettamente liscia.

The surface is perfectly smooth.



**Facilità e velocità di pulizia.**

Easy and quick cleaning.

**IGIENICO**



**Brillantezza della superficie.**

Greater surface brilliance.

**BRILLANTE**



**Sostenibilità ambientale:** ridotto consumo di acqua e detersivi per la pulizia.

Environmental Sustainability: reduced water consumption and cleaning detergents.

**GREEN**

GREEN CHALLENGE 



**Resistenza ad urti, graffi ed abrasioni.**

Impact, scratch and abrasion resistance.

**DUREVOLE**

**RESISTENTE**

Alta resistenza agli agenti esterni, maggior durevolezza nel tempo.

High resistance to external agents, longer durability



**ANTISCIVOLO**

Superficie con disegno antiscivolo.

Surface with antislip design.





-  bianco/white
-  bianco mat/white matt
-  nero/black
-  nero mat/black matt
-  sabbia/sand
-  ottanio/ottanio



# PIATTO DOCCIA **H3**

Piatto doccia e piletta di ceramica, di spessore sottilissimo, h cm 3, ideale per un motaggio a filo pavimento. Realizzabile completamente su misura.

Super thin ceramic shower tray and drain, h cm 3, ideal for floor level installation. Cut to measure.

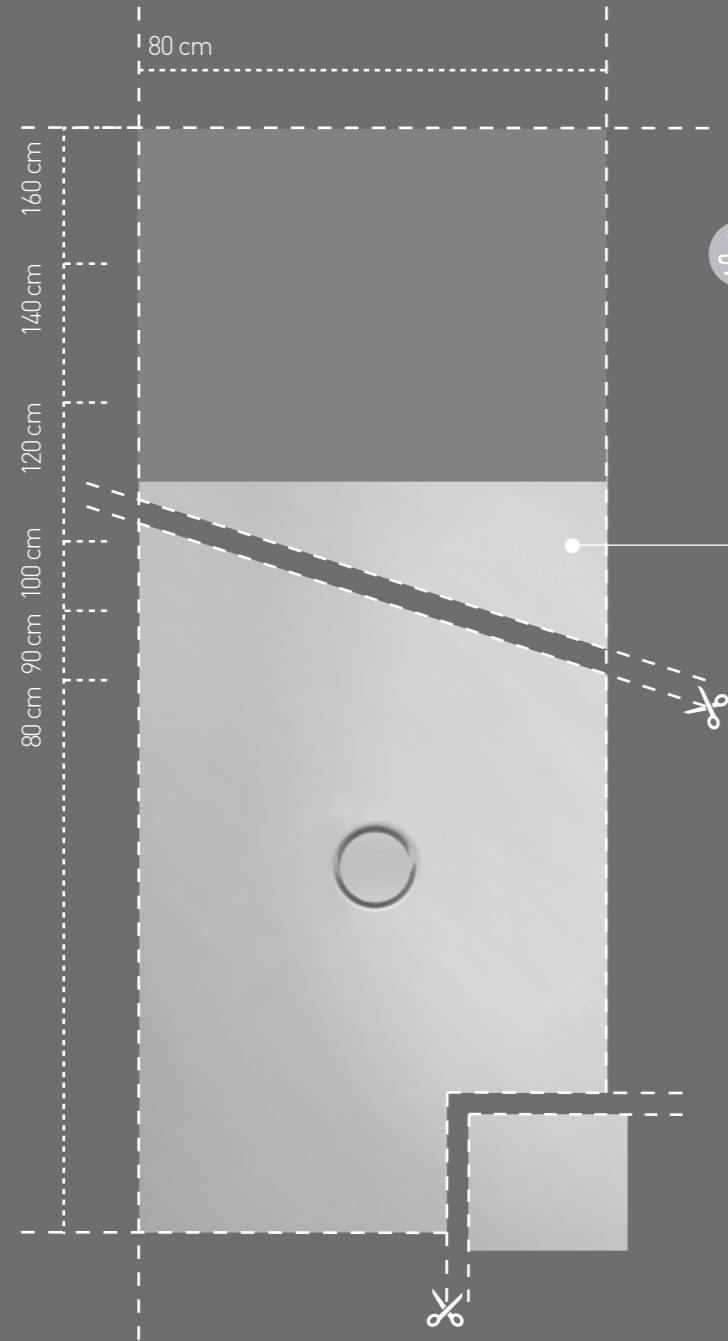

SU MISURA

Piatto doccia tagliato a misura  
Cut to measure shower tray.

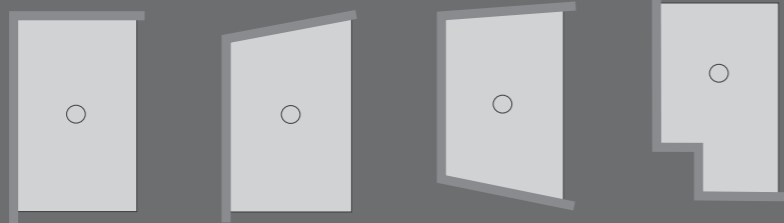



**AFFIDABILITÀ**  
/ Reliability

Ogni lavabo è testato per garantire la massima solidità e resistenza meccanica al carico di 150 Kg.

Each washbasin is tested to ensure the maximum strength and mechanical resistance of 150 kg.

**HIGHERGLAZE®**

Qualità superiore per l'innovativo smalto applicato sulla ceramica direttamente in fase di cottura. La superficie risulta essere perfettamente liscia non permettendo allo sporco e al calcare di depositarsi. Questo garantisce durevole brillantezza, piacevolezza al tatto, alta protezione da graffi, abrasioni ed agenti esterni. L'estrema facilità di pulizia inoltre permette l'utilizzo di un minor consumo di acqua e detersivi nel rispetto dell'ambiente.

Higher quality for the innovative enamel applied directly on the ceramic during firing. The surface appears to be perfectly smooth, not allowing dirt and limestone to settle. This ensures durable brilliance, pleasing to the touch, high protection from scratches, abrasions and from external agents. The extreme ease of cleaning also allows the use of a lower consumption of water and detergents, respecting the environment.

46 cm

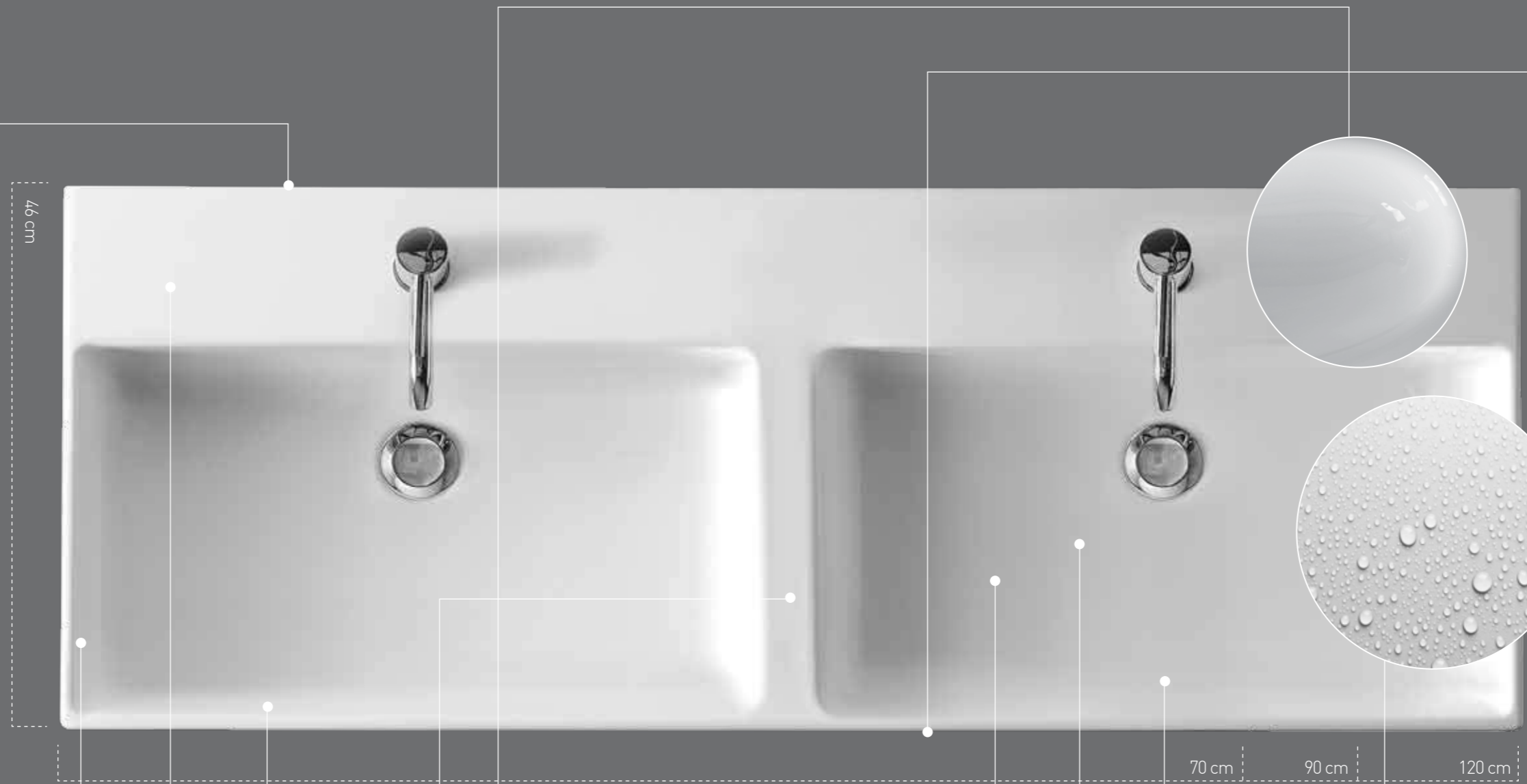

**ESTETICA**  
/ Aesthetics

Le linee decise e la riduzione degli spessori dei bordi perimetrali conferiscono alle forme dei lavabi un carattere contemporaneo.

Reduction of the washbasins edges' thickness for a more contemporary aesthetics.



**ADATTABILITÀ**  
/ Adaptability

Vasta gamma di lavabi realizzati in più formati.

A wide range of washbasins made in several sizes.

70 cm 90 cm 120 cm



**Idrorepellente:** l'acqua scivola velocemente sulla superficie.

Water-repellent: Water slides fast on the surface.



**Facilità e velocità di pulizia.**

Easy and quick cleaning.



**Sostenibilità ambientale:** ridotto consumo di acqua e detersivi per la pulizia.

Environmental Sustainability: reduced water consumption and cleaning detergents.



**Resistenza ad urti, graffi ed abrasioni.**

Impact, scratch and abrasion resistance.

**IDROREPELENTE**

**LEVIGATO**

**IGIENICO**

**BRILLANTE**

**GREEN**

**DUREVOLE**

**RESISTENTE**

La superficie risulta essere perfettamente liscia.

The surface is perfectly smooth.

Maggiore brillantezza della superficie.

Greater surface brilliance.



Alta resistenza agli agenti esterni, maggior durevolezza nel tempo.

High resistance to external agents, longer durability



MEG11 Pro

120cm  
90cm  
70cm  
60cm



46 cm



MEG11 Pro

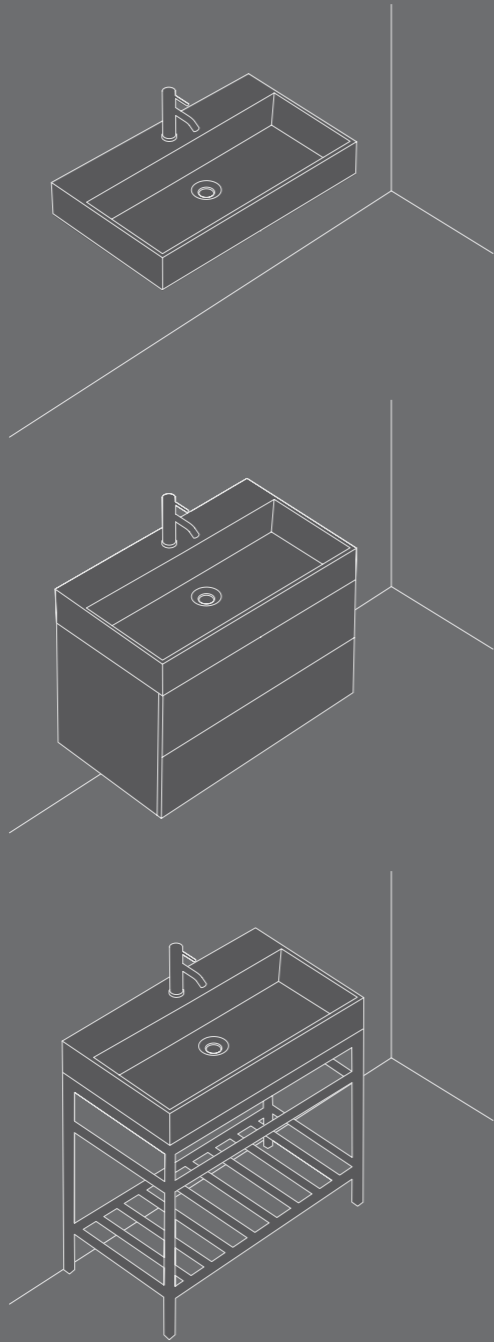

# MEG11 Pro

## ESTETICA / Aesthetics

Le linee decise e la riduzione degli spessori dei bordi perimetrali conferiscono alle forme dei lavabi un carattere contemporaneo.

Reduction of the washbasins edges' thickness for a more contemporary aesthetics.

## RIPIANO LEGNO / Wooden board

Ripiano realizzato in legno di okoumè con la funzione di tavola per il lavaggio.

Okoumè wooden board for washbasin designed for hand washing.

## HIGHERGLAZE

Innovativo smalto applicato sulla ceramica direttamente in fase di cottura. La superficie risulta essere perfettamente liscia non permettendo allo sporco e al calcare di depositarsi. Questo garantisce durevole brillantezza, piacevolezza al tatto, alta protezione da graffi, abrasioni ed agenti esterni.

Innovative enamel applied directly on the ceramic during firing. The surface appears to be perfectly smooth, not allowing dirt and limestone to settle. This ensures durable brilliance, pleasing to the touch, high protection from scratches, abrasions and from external agents.

38 cm

60 cm

150 KG

## AFFIDABILITÀ / Reliability

Ogni lavabo è testato per garantire la massima solidità e resistenza meccanica al carico di 150 Kg.

Each washbasin is tested to ensure the maximum strength and mechanical resistance of 150 kg.

## PILETTA

Piletta di scarico realizzata in acciaio inox.

Stainless steel drain.

## PIANI APPOGGIO / Shelves support

Ripiano di appoggio interno al lavabo.

Integrated ceramic shelves.

## COLORI / Colours

● bianco/white

● bianco mat/white matt



Idrorepellente: l'acqua scivola velocemente sulla superficie.

Water-repellent: Water slides fast on the surface.



## IDROREPELENTE

La superficie risulta essere perfettamente liscia.

The surface is perfectly smooth.



Facilità e velocità di pulizia.

Easy and quick cleaning.

## LEVIGATO



## IGIENICO

Maggiore brillantezza della superficie.

Greater surface brilliance.



Sostenibilità ambientale: ridotto consumo di acqua e detersivi per la pulizia.

Environmental Sustainability: reduced water consumption and cleaning detergents.

## BRILLANTE

GREEN CHALLENGE

High resistance to external agents, longer durability



## GREEN

Alta resistenza agli agenti esterni, maggior durevolezza nel tempo.

High resistance to external agents, longer durability



Resistenza ad urti, graffi ed abrasioni.

Impact, scratch and abrasion resistance.

## DUREVOLE

## RESISTENTE





MEG11 Pro

38 cm

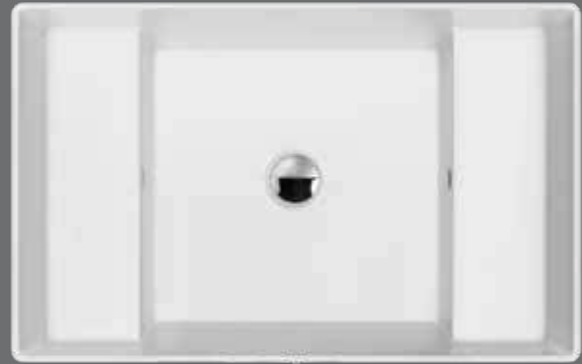

60 cm



DREAM

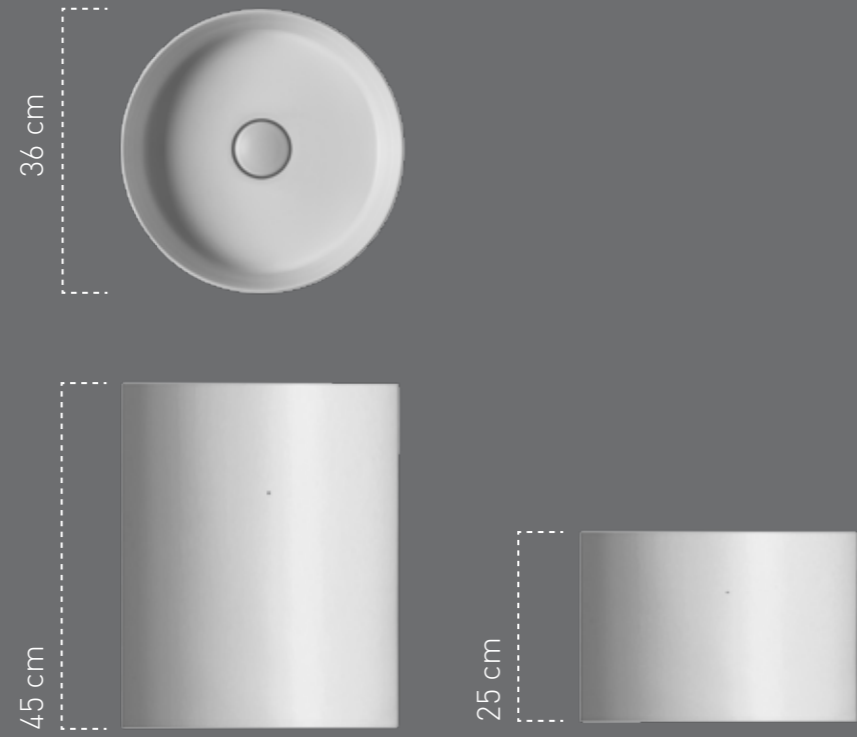

COLORI

-  **bianco**/white
-  **bianco mat**/white matt
-  **nero**/black
-  **nero mat**/black matt
-  **sabbia**/sand
-  **ottanio**/ottanio



COLORI  
/ Colours

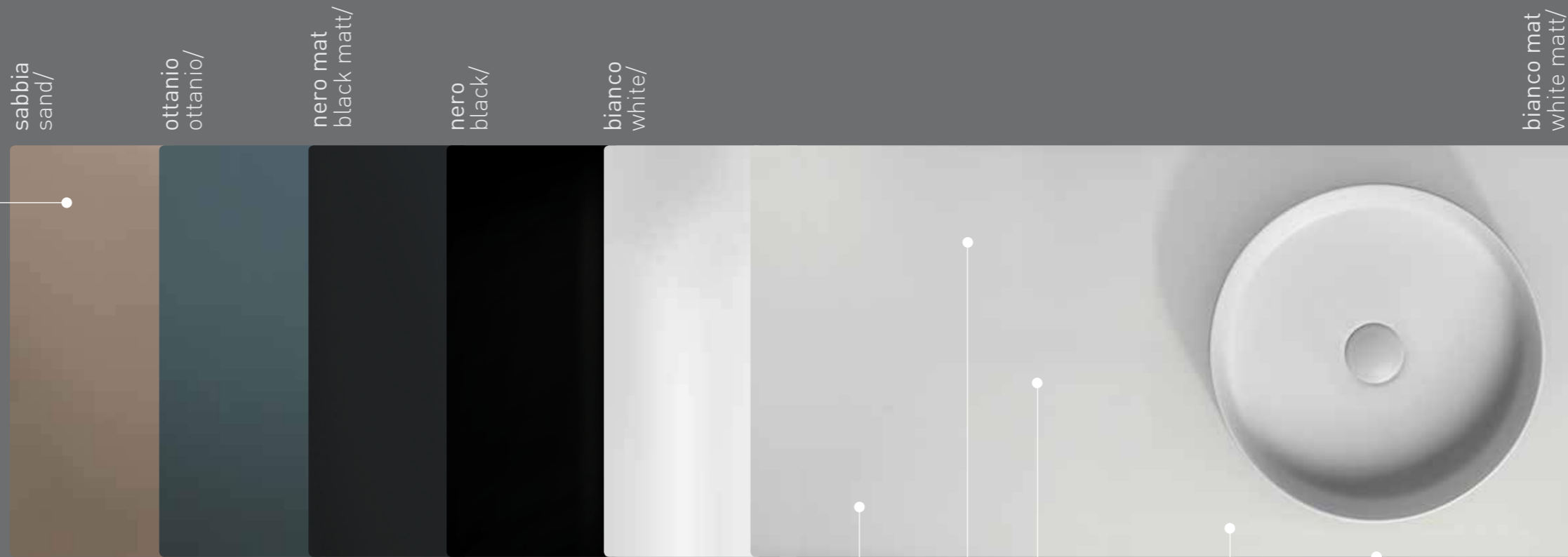

bianco mat  
white matt/



ADATTABILITÀ  
/ Adaptability

Vasta gamma di mensole realizzate in più formati.

A wide range of shelf made in several sizes.

46 cm

61 cm 81 cm 91 cm 111 cm 121 cm



SPessori SOTTILI  
/ Thicknesses

Gli spessori sottili conferiscono alla mensola leggerezza visiva ed un carattere contemporaneo.

The thin thicknesses give the shelf visual lightness and contemporary character.



ZEROBACT® è una barriera totale contro i batteri, un innovativo smalto antibatterico che viene applicato sulla ceramica direttamente in fase di cottura. È in grado di garantire una protezione duratura e definitiva da germi e batteri con un'efficacia quasi totale pari al 99,9%. Certificazione ISO 22196:2011.

ZEROBACT® is a total barrier against bacteria, an innovative antibacterial enamel which is applied directly on the ceramic during firing. The enamel is capable of ensuring a lasting and definitive protection against germs and bacteria with an effectiveness almost total, equal to 99.9%. Certification ISO 22196: 2011

Lo smalto ZEROBACT® viene fornito su richiesta. ZEROBACT® enamel is supplied on request.

I test di laboratorio hanno certificato secondo metodo ISO 22196:2011, un significativo abbattimento della carica batterica, pari al 99,9%.  
Laboratory tests certified according to ISO 22196: 2011 a significant reduction of bacterial load, equal to 99.9%



ANTIBATTERICO



Resistente al calcare e a urti ed abrasioni.

Resistant to limestone, to impact and to abrasion.

PULITO

Facilità e velocità di pulizia.

Easy and quick cleaning.

RESISTENTE

DUREVOLE

Il processo integrato di cottura dello smalto assicura maggior durevolezza delle superfici nel tempo.

The integrated process of enamel firing ensures greater durability of the surfaces over time.

# FLAT COLLECTION

MENSOLO IN CERAMICA

La mensola in ceramica FLAT è completata con la realizzazione della nuova collezione di mobili.

FLAT ceramic shelf is completed with the new furniture collection.



MENSOLO DI CERAMICA  
/ Ceramic shelf

## COLORI FINITURE MOBILE / Furniture Finishes colours

### Ecomalte

antracite/dark grey

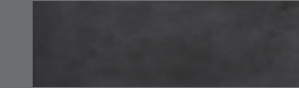

fango/mud



rosso mattone/brik red

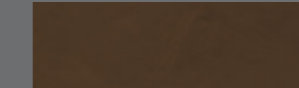

sabbia/sand



nero/black

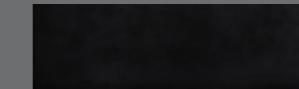

## COLORI MENSOLA / Shelf colours

bianco/white

bianco mat/white matt

sabbia/sand

nero/black

nero mat/black matt

ottanio/ottanio

## ANCORAGGIO / Anchorage

L'ancoraggio dei mobili è dotato di un particolare meccanismo di sicurezza antisgancio.

The anchorage of the furniture is equipped with a particular mechanism of hook safety catch.

## Legno

legno di recupero/raw wood



61 cm

81 cm

91 cm

111 cm

121 cm

## APERTURA "PUSH - PULL" / Opening "Push-Pull"

Il sistema Push-Pull permette, grazie all'applicazione di uno spintore con calamita, l'apertura dell'anta senza bisogno di maniglie, premendo su un punto della stessa e tirando verso l'esterno.

The Push-Pull system allows the opening of the door without the need for handles, thanks to the application of a magnet push, by pressing on a point of the same and pulling outwards.

## MATERIALI / Materials

Mobile in legno di recupero con interni placcati alluminio.

Disponibili varianti con rivestimento esterno in Ecomalta effetto cemento, un materiale innovativo, ecologico ed ecocompatibile. Materiale particolarmente adatto alla stanza da bagno: lavabile, antistatico, traspirante, ingelivo (non modifica le sue caratteristiche con sbalzi di temperatura), ignifugo e resistente e flessibile al tempo stesso.

Raw wood furniture with aluminum plated interiors.

Available versions with exterior coating in Ecomalta cement effect, an innovative, ecological and environmentally friendly material. This material is particularly suitable for the bathroom: washable, antistatic, breathable, frost resistant (it does not modify its characteristics with temperature changes), fireproof and resistant and flexible at the same time.



## ADATTABILITÀ / Adaptability

Vasta gamma di mobili realizzati in più formati.

A wide range of furniture made in several sizes.

## CHIUSURA RALLENTATA / Soft close

Il sistema di chiusura adopera guide a scomparsa BLUM con tecnologia BLUMOTION per una chiusura silenziosa e rallentata.

The closure system uses BLUM concealed runner with BLUMOTION technology for a slow and silent closing.

La mensola in ceramica FLAT è completata con la realizzazione della nuova collezione di strutture in metallo.



FLAT ceramic shelf is completed with the new collection of metal structures.

STRUTTURA IN METALLO  
/ Metal structure

Struttura realizzata in metallo verniciato finitura rame o nero opaco.

Metal structure with copper or black matte finish.

COLORI STRUTTURA  
/ Structure colours

-  rame/copper
-  nero matte/black matte



ADATTABILITÀ  
/ Adaptability

Vasta gamma di strutture realizzate in più formati.

A wide range of structures made in several sizes.

MENSOLA DI CERAMICA  
/ Ceramic shelf

COLORI MENSOLA  
/ Shelf colours

-  bianco/white
-  bianco mat/white matt
-  sabbia/sand
-  nero/black
-  nero mat/black matt
-  ottanio/ottanio

HIGHERGLAZE

Innovativo smalto applicato sulla ceramica direttamente in fase di cottura. La superficie perfettamente liscia non permette a sporco e calcare di depositarsi. Questo garantisce durevole brillantezza, piacevolezza al tatto, alta protezione da graffi, abrasioni ed agenti esterni.

Innovative enamel applied directly on the ceramic during firing. The surface perfectly smooth not allowing dirt and limestone to settle. This ensures durable brilliance, pleasing to the touch, high protection from scratches, abrasions and from external agents.



Idrorepellente: l'acqua scivola velocemente sulla superficie.

Water-repellent: Water slides fast on the surface.



LEVIGATO

La superficie risulta essere perfettamente liscia.

The surface is perfectly smooth.



Facilità e velocità di pulizia.

Easy and quick cleaning.



BRILLANTE

Maggiore brillantezza della superficie.

Greater surface brilliance.



Sostenibilità ambientale: ridotto consumo di acqua e detersivi per la pulizia.

Environmental Sustainability: reduced water consumption and cleaning detergents.

GREEN

GREEN CHALLENGE



Resistenza ad urti, graffi ed abrasioni.

Impact, scratch and abrasion resistance.

DUREVOLE

Alta resistenza agli agenti esterni, maggior durevolezza nel tempo.

High resistance to external agents, longer durability.

RESISTENTE

IDROREPELLENTE

LEVIGATO

IGIENICO

BRILLANTE

GREEN

DUREVOLE

RESISTENTE

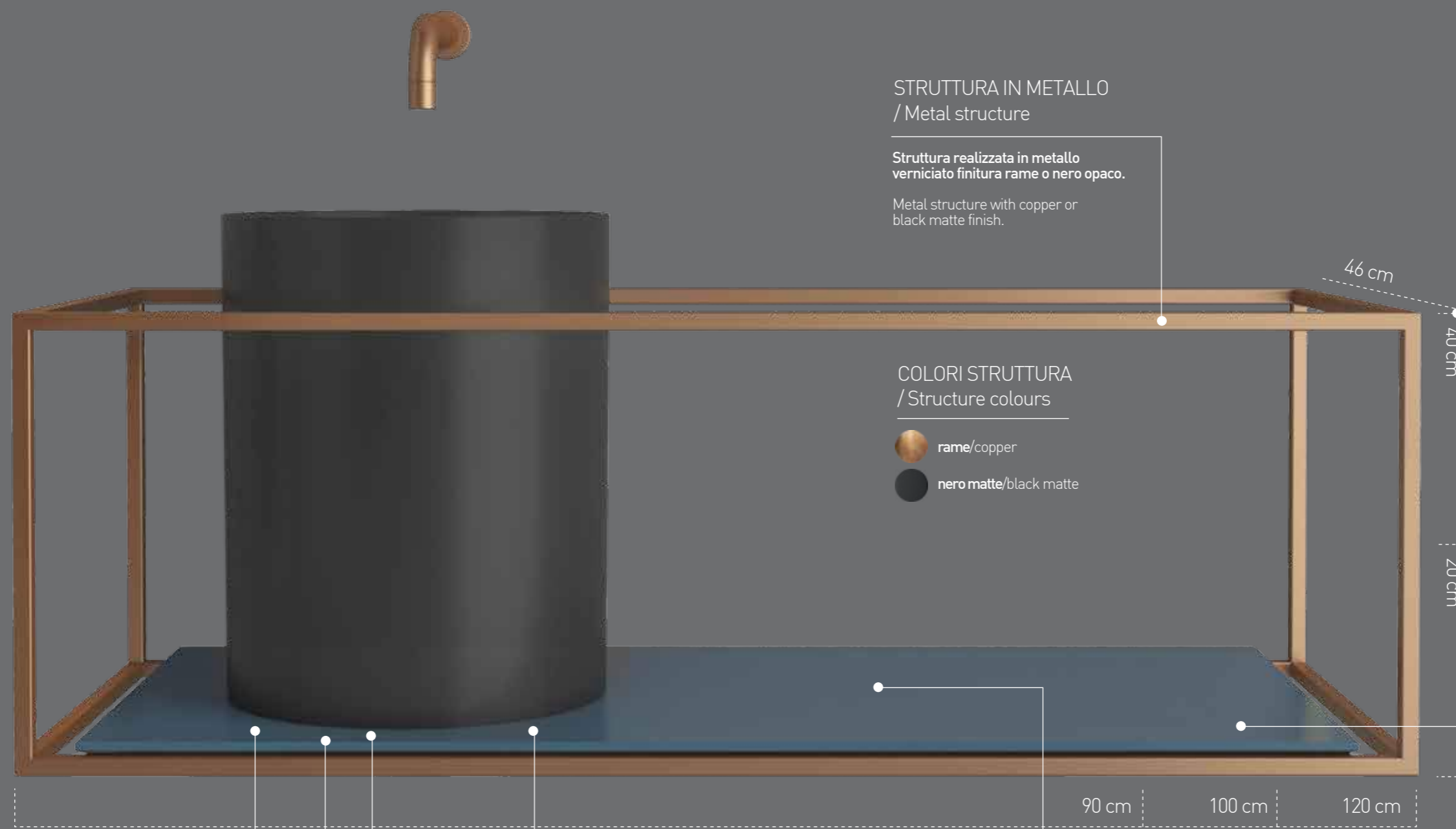

FLAT COLLECTION  
MENSOLA IN CERAMICA

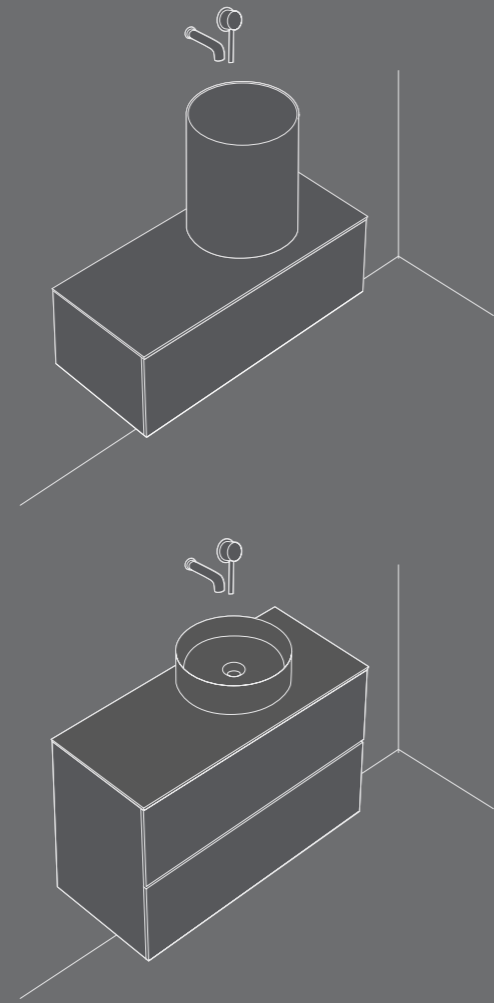

FLAT COLLECTION  
MENSOLA IN CERAMICA

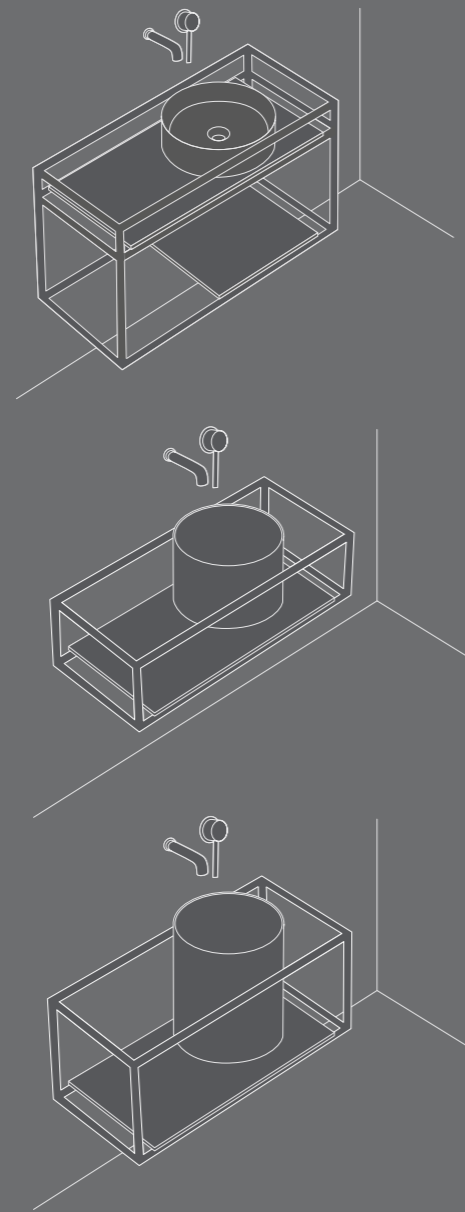

FLAT COLLECTION  
MENSOLA IN CERAMICA

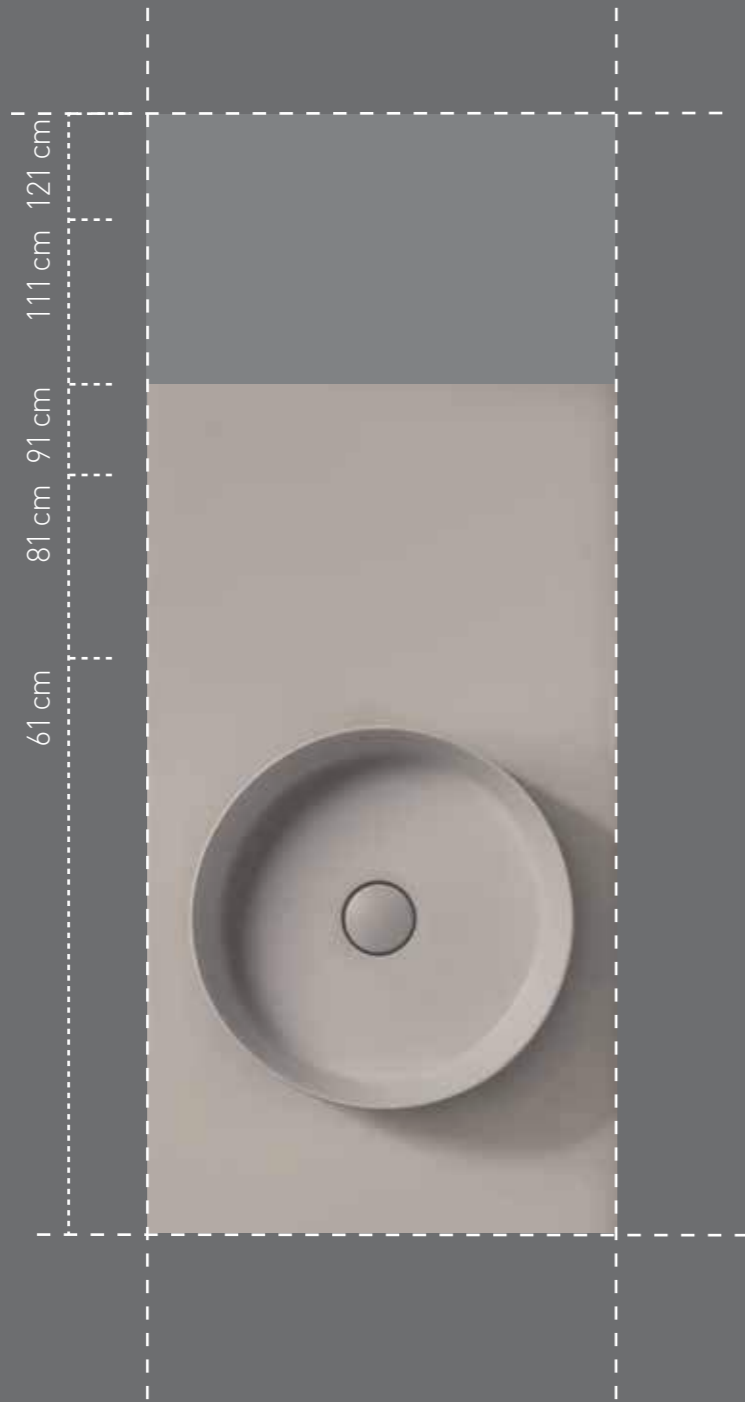



FLAT COLLECTION  
MENSOLA IN CERAMICA

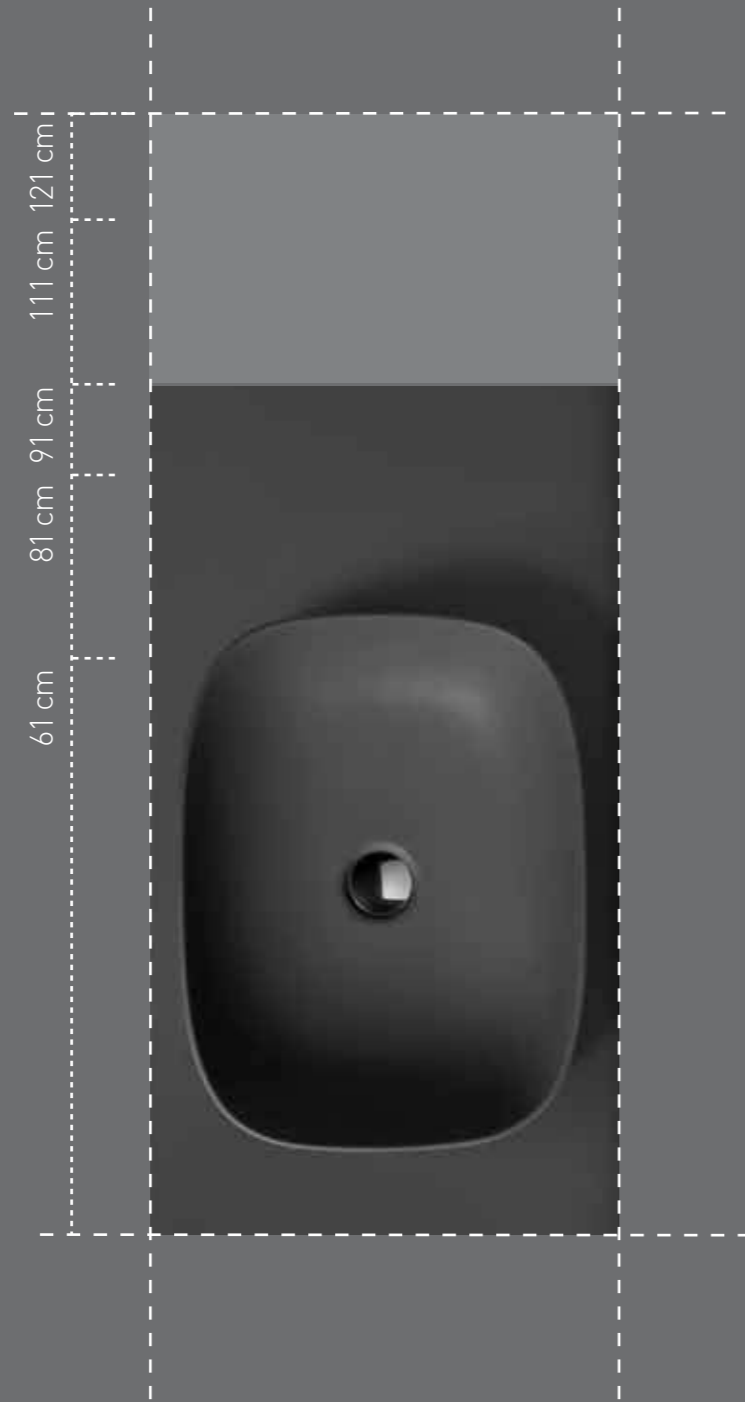

FLAT COLLECTION  
MENSOLA IN CERAMICA



La collezione DREAM si completa con la realizzazione del nuovo lavabo ultrasottile ( 5 mm di spessore ).

The Dream collection is completed with a new ultra-thin washbasin ( 5mm thickness ).

**HIGHERGLAZE**

Qualità superiore per l'innovativo smalto applicato sulla ceramica direttamente in fase di cottura. La superficie risulta essere perfettamente liscia non permettendo allo sporco e al calcare di depositarsi. Questo garantisce durevole brillantezza, piacevolezza al tatto, alta protezione da graffi, abrasioni ed agenti esterni. L'estrema facilità di pulizia inoltre permette l'utilizzo di un minor consumo di acqua e detersivi nel rispetto dell'ambiente.

Higher quality for the innovative enamel applied directly on the ceramic during firing. The surface appears to be perfectly smooth, not allowing dirt and limestone to settle. This ensures durable brilliance, pleasing to the touch, high protection from scratches, abrasions and from external agents. The extreme ease of cleaning also allows the use of a lower consumption of water and detergents, respecting the environment.



**Idrorepellente:** l'acqua scivola velocemente sulla superficie.

Water-repellent: Water slides fast on the surface.



**LEVIGATO**

La superficie risulta essere perfettamente liscia.

The surface is perfectly smooth.



**Facilità e velocità di pulizia.**

Easy and quick cleaning.



**BRILLANTE**

Maggiore brillantezza della superficie.

Greater surface brilliance.



**Sostenibilità ambientale:** ridotto consumo di acqua e detersivi per la pulizia.

Environmental Sustainability: reduced water consumption and cleaning detergents.

**GREEN**



**DUREVOLE**

Alta resistenza agli agenti esterni, maggior durevolezza nel tempo.

High resistance to external agents, longer durability



**Resistenza ad urti, graffi ed abrasioni.**

Impact, scratch and abrasion resistance.

**RESISTENTE**

46 cm

91 cm



**SPessori SOTTILI / Thicknesses**

La riduzione degli spessori dei bordi perimetrali esterni conferiscono alle forme dei lavabi un carattere contemporaneo.

Reduction of the washbasins external edges' thickness for a more contemporary aesthetics.

**PILETTA**

Piletta di scarico realizzata in ceramica.

Ceramic steel drain.

**COLORI / colours**



bianco/white



bianco mat/white matt



sabbia/sand



nero/black



nero mat/black matt



ottanio/ottanio

# DREAM

Il nuovo lavabo DREAM è completato con la realizzazione della nuova collezione di mobili.

The new DREAM washbasin is combined with a new furniture collection.

## MATERIALI / Materials

Mobile con finitura in Ecomalta effetto cemento, un materiale innovativo, ecologico ed ecocompatibile. Materiale particolarmente adatto alla stanza da bagno: lavabile, antistatico, traspirante, ingelivo (non modifica le sue caratteristiche con sbalzi di temperatura), ignifugo e resistente e flessibile al tempo stesso.

Disponibile anche la versione in legno di recupero con interni in alluminio.

Furniture with exterior coating in Ecomalta cement effect, an innovative, ecological and environmentally friendly material. This material is particularly suitable for the bathroom: washable, antistatic, breathable, frost resistant (it does not modify its characteristics with temperature changes), fireproof and resistant and flexible at the same time.

Available version with aluminum plated interiors.

Particolare dell'interno attrezzato dei cassetti  
/ Inside equipped drawer



## COLORI FINITURE MOBILE / Furniture Finishes colours

### Ecomalte

antracite/dark grey

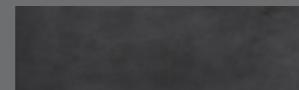

fango/mud



rosso mattone/brik red



sabbia/sand



nero/black

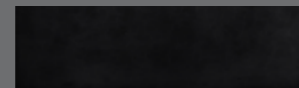

### Legno

legno di recupero/raw wood



## CHIUSURA RALLENTATA / Soft close

Il sistema di chiusura adopera guide a scomparsa BLUM con tecnologia BLUMOTION per una chiusura silenziosa e rallentata.

The closure system uses BLUM concealed runner with BLUMOTION technology for a slow and silent closing.

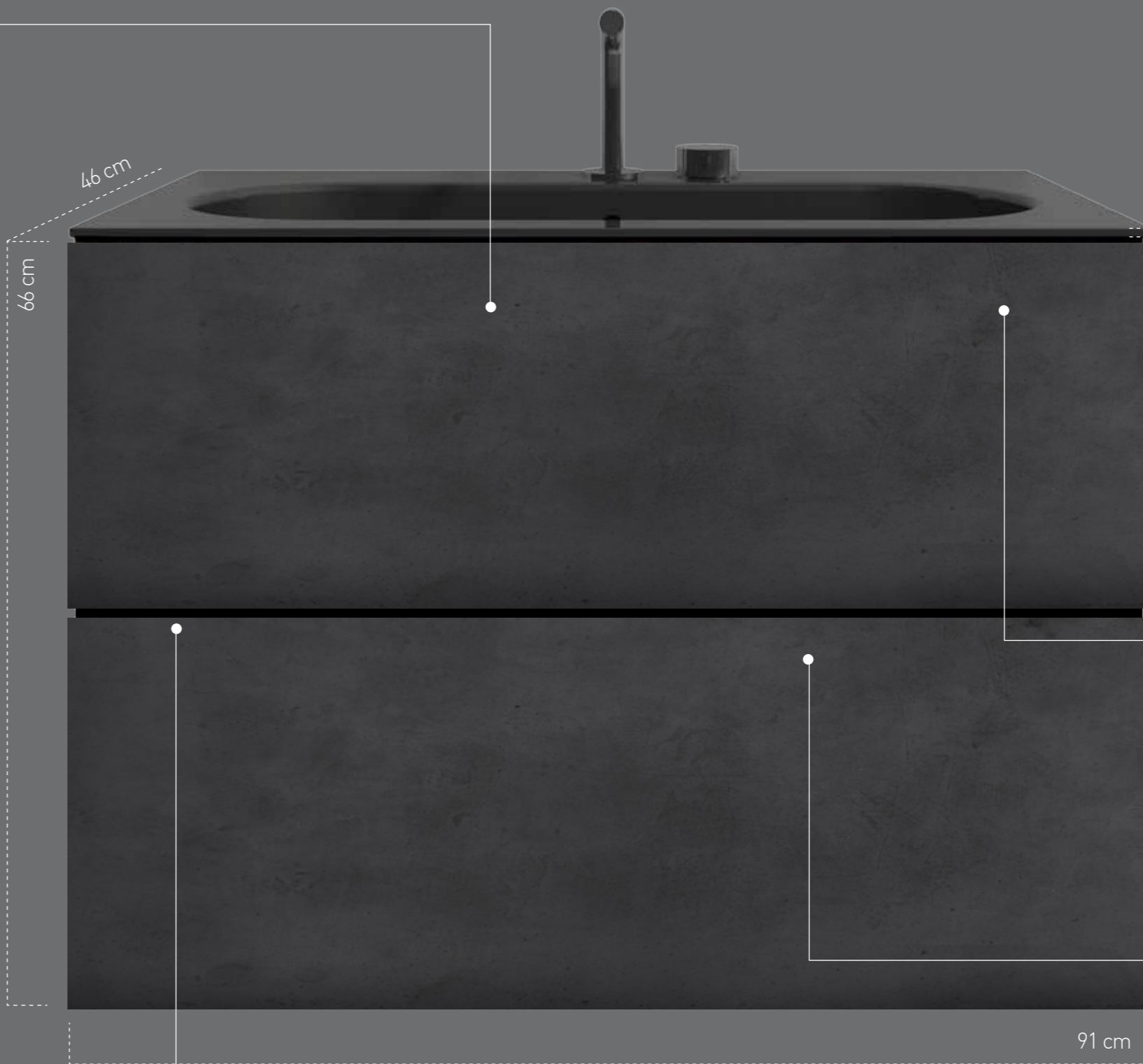

## SPessori SOTTILI / Thicknesses



La riduzione degli spessori dei bordi perimetrali esterni conferiscono alle forme dei lavabi un carattere contemporaneo.

Reduction of the washbasins external edges' thickness for a more contemporary aesthetics.

## ANCORAGGIO / Anchorage

L'ancoraggio dei mobili è dotato di un particolare meccanismo di sicurezza antisgancio.

The anchorage of the furniture is equipped with a particular mechanism of hook safety catch.

## APERTURA "PUSH - PULL" / Opening "Push-Pull"

L'apertura con sistema Push-Pull permette, grazie all'applicazione di uno spintore con calamita, l'apertura dell'anta senza bisogno di maniglie, premendo su un punto della stessa e tirando verso l'esterno.

The Push-Pull system allows the opening of the door without the need for handles, thanks to the application of a magnet push, by pressing on a point of the same and pulling outwards.

DREAM

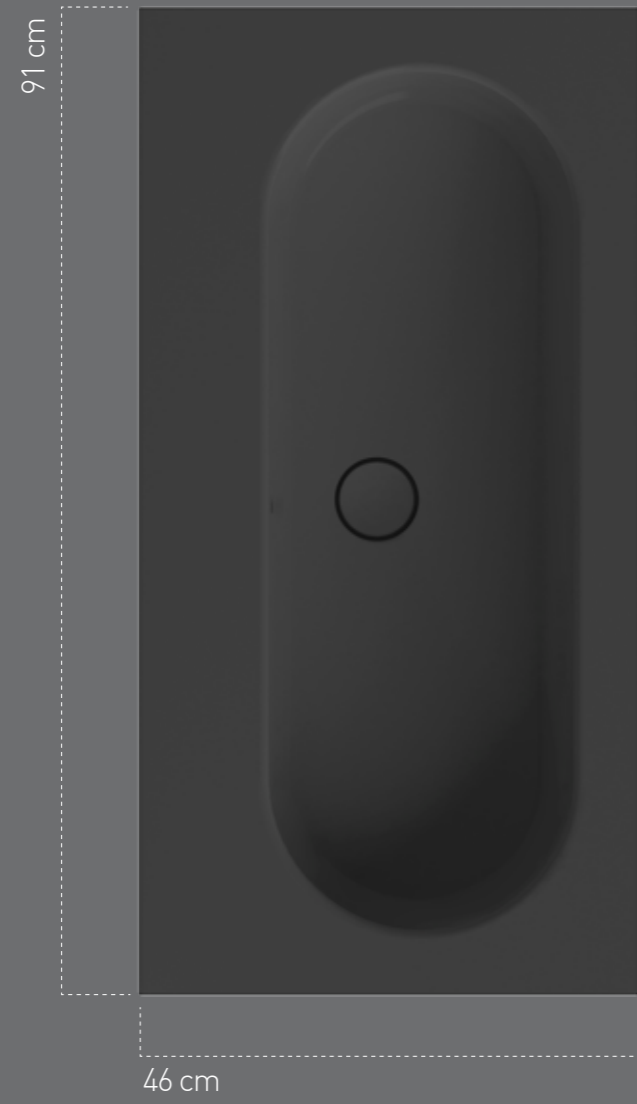



ZEROBACT® è una barriera totale contro i batteri, un innovativo smalto antibatterico che viene applicato sulla ceramica direttamente in fase di cottura. È in grado di garantire una protezione duratura e definitiva da germi e batteri con un'efficacia quasi totale pari al 99,9%.  
Certificazione ISO 22196:2011.

ZEROBACT® is a total barrier against bacteria, an innovative antibacterial enamel which is applied directly on the ceramic during firing. The enamel is capable of ensuring a lasting and definitive protection against germs and bacteria with an effectiveness almost total, equal to 99.9%.  
Certification ISO 22196: 2011

Lo smalto ZEROBACT® viene fornito su richiesta.  
ZEROBACT® enamel is supplied on request.

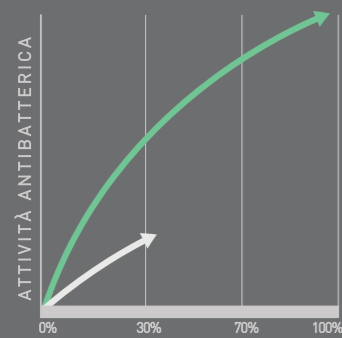

I test di laboratorio hanno certificato secondo metodo ISO 22196:2011, un significativo abbattimento della carica batterica, pari al 99,9%.

Laboratory tests certified according to ISO 22196:2011 a significant reduction of bacterial load, equal to 99.9%

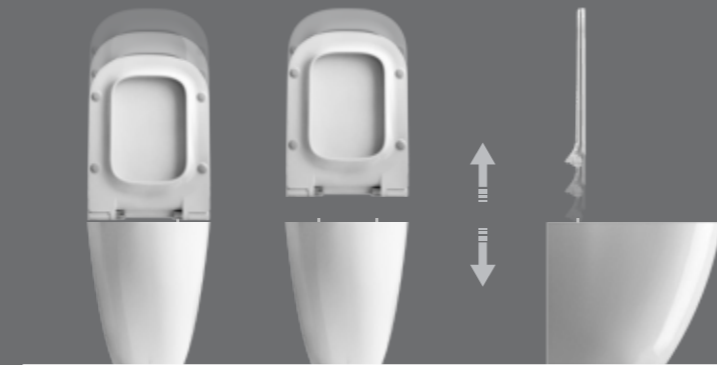

### SGANCIO RAPIDO / Quick release

Il nuovo dispositivo di sgancio rapido permette di estrarre il coprivaso in maniera semplice, agevolando così una più facile pulizia.

The new quick-release device allows to take the toilet seat off in a simple manner, making it easier to clean.

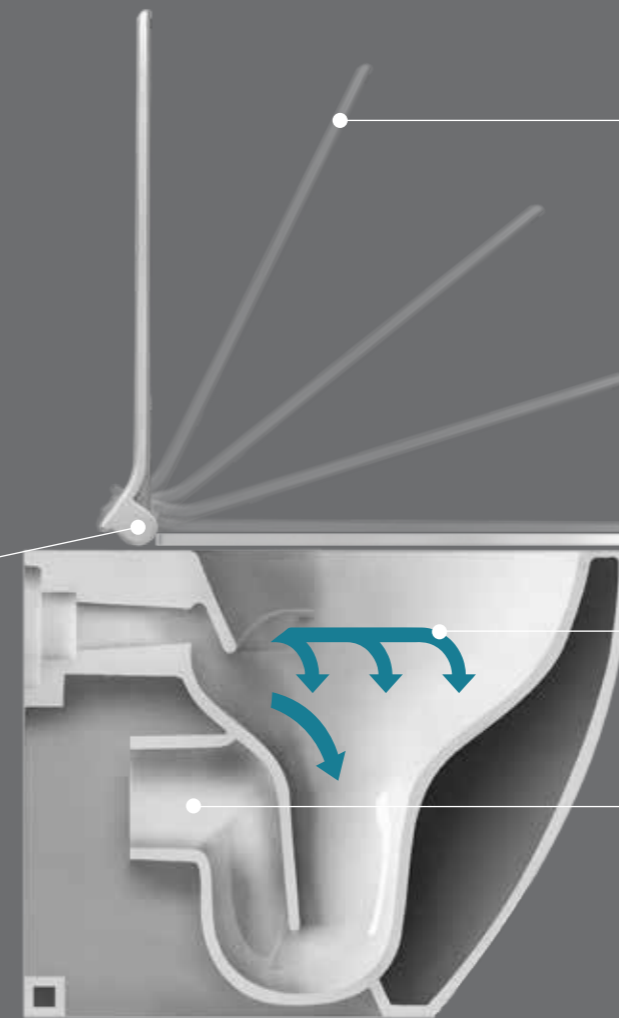

### SOFT CLOSE

Coprivaso avvolgente realizzato in resina termoindurente con meccanismo a chiusura rallentata.

Thermosetting seat cover with soft closing system.

### RIM AWAY

Nuovo sistema di scarico che permette all'acqua una più rapida ed accurata pulizia utilizzando solo 3 litri d'acqua per il risciacquo.

New drainage system which allows a more rapid and careful cleaning using only 3 liters of water for rinsing.

### SIFONE SMALTATO / Glazed siphon

Il sifone smaltato permette un utilizzo più igienico e duraturo

The glazed siphon allows a more hygienic and long lasting use.

ANTIBATTERICO

99,9%

PULITO

RESISTENTE

DUREVOLE

Facilità e velocità di pulizia.

Easy and quick cleaning.

Il processo integrato di cottura dello smalto assicura maggior durevolezza delle superfici nel tempo.

The integrated process of enamel firing ensures greater durability of the surfaces over time.

Resistente al calcare e a urti ed abrasioni.

Resistant to limestone, to impact and to abrasion.

### COLORI / Colours

- bianco/white
- bianco mat/white matt
- sabbia/sand
- nero/black
- nero mat/black matt



# MEG11 Pro WC - BIDET

## FINISHES



Bianco/White



MT Bianco mat/White matt



NEMT Nero/Black



NEMT Nero mat/Black matt



SA Sabbia/Sand

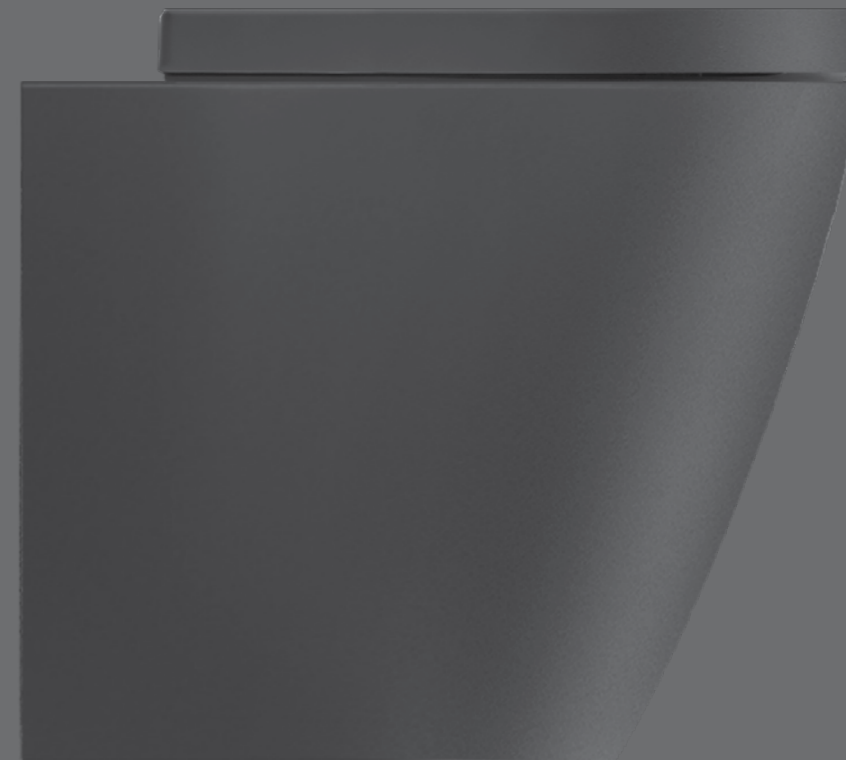
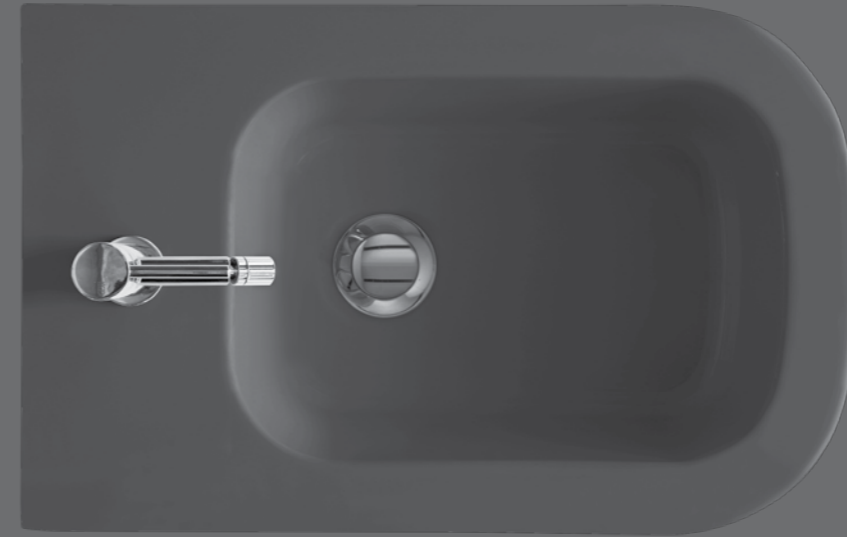

MEG11 Pro WC - BIDET

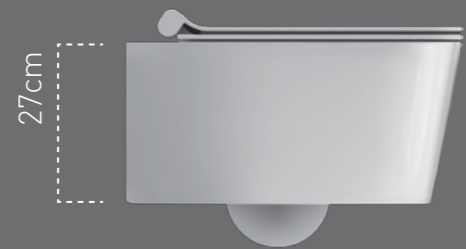
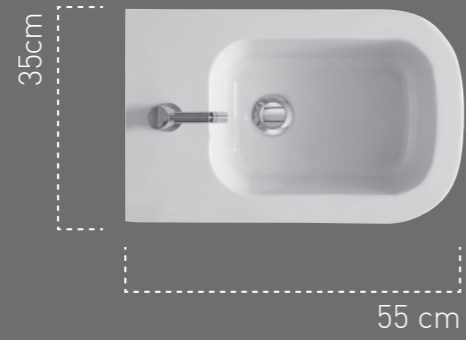

-  Rim Away
-  Soft Close
-  Sgancio rapido  
Quick-release system
-  Sifone smaltato  
Glazed siphon
-  Fissaggio nascosto  
Hidden fixing







ZEROBACT® è una barriera totale contro i batteri, un innovativo smalto antibatterico che viene applicato sulla ceramica direttamente in fase di cottura. È in grado di garantire una protezione duratura e definitiva da germi e batteri con un'efficacia quasi totale pari al 99,9%.  
Certificazione ISO 22196:2011.

ZEROBACT® is a total barrier against bacteria, an innovative antibacterial enamel which is applied directly on the ceramic during firing. The enamel is capable of ensuring a lasting and definitive protection against germs and bacteria with an effectiveness almost total, equal to 99.9%.  
Certification ISO 22196: 2011

Lo smalto ZEROBACT® viene fornito su richiesta.  
ZEROBACT® enamel is supplied on request.

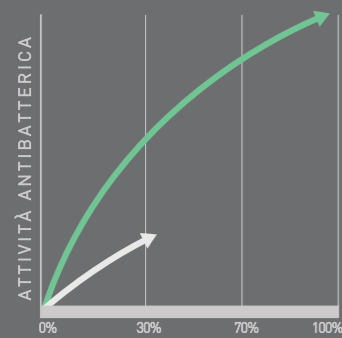

I test di laboratorio hanno certificato secondo metodo ISO 22196:2011, un significativo abbattimento della carica batterica, pari al 99,9%.

Laboratory tests certified according to ISO 22196: 2011 a significant reduction of bacterial load, equal to 99.9%

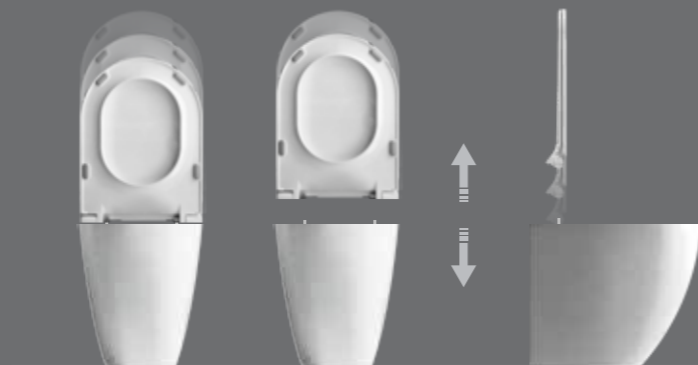

## SGANCIO RAPIDO / Quick release

Il nuovo dispositivo di sgancio rapido permette di estrarre il coprivaso in maniera semplice, agevolando così una più facile pulizia.

The new quick-release device allows to take the toilet seat off in a simple manner, making it easier to clean.

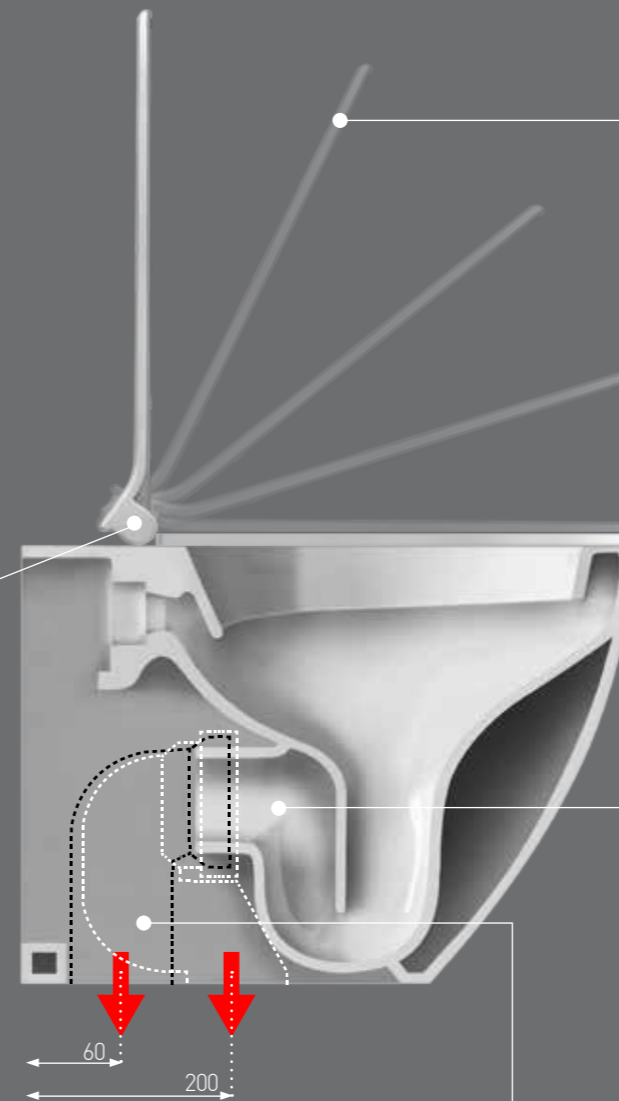

## SOFT CLOSE

Coprivaso avvolgente realizzato in resina termoindurente con meccanismo a chiusura rallentata.

Thermosetting seat cover with soft closing system.

## SIFONE SMALTATO / Glazed siphon

Il sifone smaltato permette un utilizzo più igienico e duraturo

The glazed siphon allows a more hygienic and long lasting use.

## COLORI / Colours

- bianco/white
- bianco matte/white matte

## SCARICO TRASLATO

Nuova soluzione tecnica che agevola gli interventi di ristrutturazione: l'installazione avviene senza dover intervenire su impianti di scarico già esistenti con foro di scarico distante dalla parete da 6 a 20 cm.

Floor drain adjustable flush  
New technical solution which makes the renovation work easier: the installation is done without compromising existing installations with a discharge hole far from the wall 6 to 20 cm.



DREAM WC - BIDET

FINISHES



Bianco/White



MT Bianco mat/White matt



DREAM

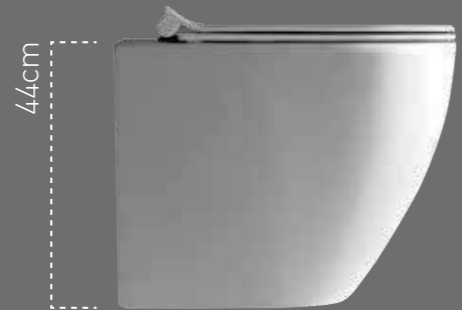

-  Rim Away
-  Soft Close
-  Sgancio rapido  
Quick-release system
-  Sifone smaltato  
Glazed siphon
-  Fissaggio nascosto  
Hidden fixing



# PIATTO DOCCIA BETON

Beton è un nuovo concetto di piatto doccia extrasottile, solo 3 cm di spessore, e personalizzabile su misura. Realizzato in MINERAL STONE, un innovativo e moderno materiale esclusivo di Ceramica Galassia composto da resina, polveri di marmo e pietre naturali.

Beton is an innovative shower tray concept idea with an extra thickness of only 3 cm which can be cut to measure. MINERAL STONE, a new and modern material exclusively by Ceramica Galassia, composed of resins and powders from marble and natural stones.

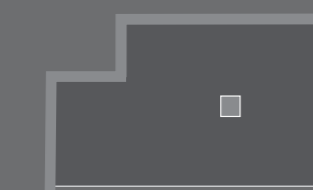
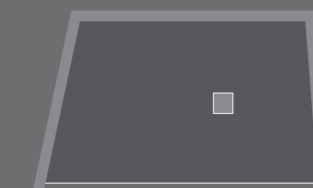

## SU MISURA

**Piatto doccia tagliato a misura**

Cut to measure shower tray.



## ANTISCIVOLO

**Antiscivolo classe3-R11.**

Class 3-R11 antislip.



## ANTIMACCHIA

**Resistente alle macchie.**

Resistant to stains.



## ANTI ABRASIONI

**Resistente alle abrasioni.**

Resistant to abrasions.



## ANTIMUFFA

**Resistente alla muffa.**

Resistant to mold.



## ADATTABILITÀ

**Vasta gamma di piatti doccia realizzati in più formati.**

A wide range of shower tray made in several sizes.

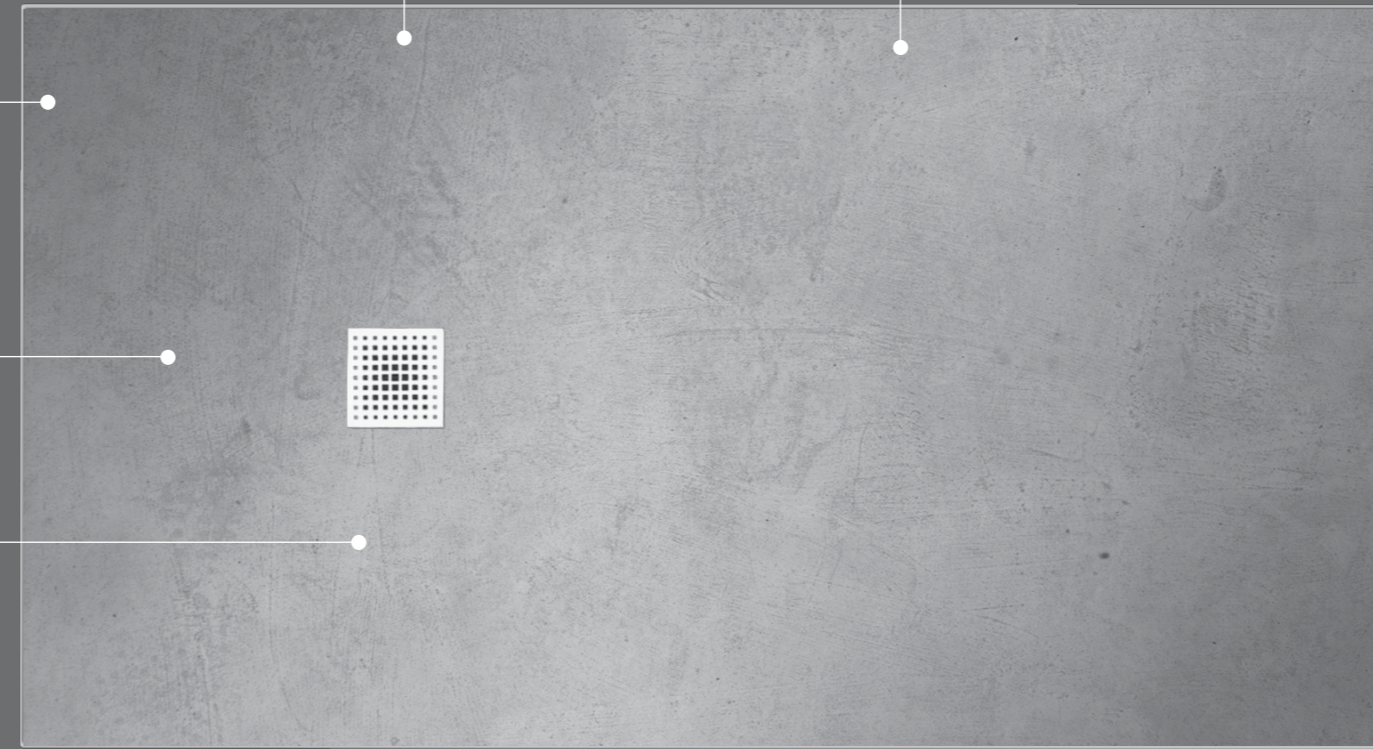

80 cm  
70 cm

80 cm 90 cm 100 cm 110 cm 120 cm 130 cm 140 cm 150 cm 160 cm 170 cm 180 cm

## COLORI / colours

**grigio cemento /concrete grey**

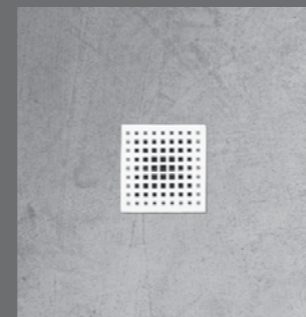

**bianco/white**

