

# ITALGRANITI

EXCLUSIVE ITALIAN SURFACES

## Year Book 2026



# ITALGRANITI

EXCLUSIVE ITALIAN SURFACES

## **06 Italgraniti Group**

- 08 Sustainability
- 10 New slabs plant
- 14 Circularity & recycling
- 16 New paradigm in ceramic surfaces
- 18 AI-Driven innovations
- 20 Innovative technologies
- 26 Mega®
- 30 Italstone®
- 32 Open®
- 34 New dimension 120x120x0.9 cm
- 36 Loom
- 40 Art Direction
- 42 Made in Italy

## **44 2026 Collections**

- 44 Marble Effect
- 120 Stone Effect
- 218 Concrete & Metal Effect
- 274 Color Effect
- 320 Wood Effect

## **356 LOOM**

- 358 Gallery
- 364 Products
- 371 Price List

## **376 Technical Information**

- 378 Certifications
- 388 Special trims 9 mm
- 390 Special trims 20 mm
- 396 Mega: handling, installation, packaging
- 408 Installation advice 9 mm thickness
- 410 Recommended adhesives
- 412 Grouting and cleaning after installation
- 414 Extraordinary cleaning
- 415 Working size chart
- 416 Technical specifications porcelain stoneware
- 418 Symbol captions
- 420 General conditions of sale

## **44 Marble Effect**

- 46 Calcis
- 62 Marble Touch
- 76 I Travertini
- 98 Marble
  - Charm Experience
  - Lux Experience
  - Marble Experience

## **120 Stone Effect**

- 122 Natural
- 142 Dorset
- 160 Origins
- 178 Shale
- 192 Silver Grain + Ceppo di Gré
- 208 Nordic Stone
- 214 Stone Mix

## **218 Concrete & Metal Effect**

- 220 I Cementi
- 244 Terre
- 260 Metaline















## **274 Color Effect**

- 276 Nuances

## **320 Wood Effect**

- 322 Essence Select
- 332 Essence
- 342 Allure
- 350 Alnus



	Marble Effect						Stone Effect						Concrete, Metal & Color Effect			Wood Effect							
	Calcis	Marble Touch	I Travertini	Charm Experience	Lux Experience	Marble Experience	Natural	Dorset	Origins	Shale	Silver Grain	Ceppo Di Grè	Nordic Stone	Stone Mix	I Cementi	Terre	Metaline	Nuances	Essence Select	Essence	Allure	Alnus	
<b>■ 6 mm</b>																							
 120x280 cm 47 <sup>1/4</sup> "x110 <sup>1/4</sup> "	■	■	■	■	■	■	■	■	■	■	■	■	■	■	■	■	■	■	■	■	■	■	■
<b>■ 12 mm</b>																							
 160x320 cm 62 <sup>7/8</sup> "x125 <sup>3/4</sup> "	■	■	■	■	■	■											■						
<b>■ 9 mm</b>																							
 120x120 cm 47 <sup>1/4</sup> "x47 <sup>1/4</sup> "	■	■	■	■		■	■	■	■	■	■	■	■	■	■	■	■	■	■	■	■	■	■
 80x160 cm 31 <sup>1/2</sup> "x63"			■				■		■	■		■					■						
 80x80 cm 31 <sup>1/2</sup> "x31 <sup>1/2</sup> "	■						■	■	■	■	■	■	■	■	■	■	■	■	■	■	■	■	■
 60x120 cm 23 <sup>1/2</sup> "x47 <sup>1/4</sup> "	■	■	■	■	■	■	■	■	■	■	■	■	■	■	■	■	■	■	■	■	■	■	■
 20x120 cm 8"x47 <sup>1/4</sup> "											■								■	■	■	■	■
 60x60 cm 23 <sup>1/2</sup> "x23 <sup>1/2</sup> "	■	■	■			■	■	■	■	■	■	■	■	■	■	■	■	■	■	■	■	■	■
 30x60 cm 11 <sup>7/8</sup> "x23 <sup>1/2</sup> "	■		■				■	■	■	■	■	■	■	■	■	■	■	■	■	■	■	■	■
 15x60 cm 6"x23 <sup>1/2</sup> "										■													
 10x30 cm 4"x11 <sup>7/8</sup> "										■													
 9x50 cm 3 <sup>1/2</sup> "x19 <sup>3/4</sup> "																							
<b>■ 20 mm - OPEN</b>																							
 60x120 cm 23 <sup>1/2</sup> "x47 <sup>1/4</sup> "	■		■				■	■	■	■	■	■	■	■	■	■	■	■	■	■	■	■	■
 60x60 cm 23 <sup>1/2</sup> "x23 <sup>1/2</sup> "							■	■	■	■	■	■	■	■	■	■	■	■	■	■	■	■	■

Index by sizes

## Italgraniti Group Milestones.

## 30 years of innovation and ceramic design.



### 1950

Nell'immediato dopoguerra, Romeo Giacobazzi e sua moglie Afra Fontana, entrambi imprenditori, partecipano alla ricostruzione del tessuto economico e sociale del Paese fondando una tra le prime aziende del distretto ceramico emiliano.

Immediately after the war, Romeo Giacobazzi and his wife Afra Fontana, both entrepreneurs, participated in the reconstruction of the economic and social fabric of the country by founding one of the first companies in the Emilia ceramic district.



### 1994

Nel 1994 Dante Giacobazzi, figlio di Romeo e Afra, co-fonda Italgraniti. L'anno successivo entra in funzione lo stabilimento di San Martino in Rio, dedicato alla produzione di gres porcellanato.

In 1994 Dante Giacobazzi, son of Romeo and Afra, co-founded Italgraniti. The following year, the San Martino in Rio factory, dedicated to the production of porcelain stoneware, began operations.



### 2003

Dal team di ricerca Italgraniti nasce, con il supporto tecnico di Sacmi, il primo prototipo di pressa Continua per i grandi formati, che entra in funzione nel 2003.

The Italgraniti research team created, with the technical support of Sacmi, the first prototype of Continua press for large formats, which entered into operation in 2003.



### 2015

Tra 2013 e 2015 lo stabilimento di San Martino in Rio viene completamente rinnovato e, in un'ottica industry 4.0, dotato di tecnologie digitali dedicate all'automazione delle linee, alla razionalizzazione dei processi e alla riduzione dei consumi.

Between 2013 and 2015, the San Martino in Rio plant was completely renovated and, in an industry 4.0 perspective, equipped with digital technologies dedicated to line automation, process rationalization and consumption reduction.



### 2022

Nel 2022 Italgraniti Group pubblica il suo primo bilancio di sostenibilità e ottiene la certificazione B Corp.

In 2022 Italgraniti Group published its first sustainability report and obtained the B Corp certification.



### 1960

In poco tempo arrivano a occupare 2.000 persone e a produrre oltre 20 milioni di mq/anno di piastrelle da pavimento e rivestimento.

In a short time they reach to occupy 2,000 people and to produce more than 20 million sqm/year of floor and wall tiles.



### 1998

In pochi anni Italgraniti raggiunge un ruolo da leader nel settore del gres porcellanato tecnico italiano e nel 1998 acquisisce Impronta, storico brand attivo dal 1974.

In a few years Italgraniti achieved a leading role in the Italian technical porcelain stoneware sector and in 1998 acquired Impronta, a historic brand active since 1974.



### 2007

Dante Giacobazzi viene poi affiancato dalla figlia Elisa e dal genero Francesco Maturo. Insieme guidano l'azienda secondo gli stessi valori di innovazione e di cultura imprenditoriale di sempre.

Dante Giacobazzi was then joined by his daughter Elisa and his son-in-law Francesco Maturo. Together they guide the company according to the same values of innovation and entrepreneurial culture as always.



### 2021

Tra il 2021 e il 2022 lo stabilimento produttivo viene dotato di una nuova linea di pressatura Continua+, di un post-combustore e di un cogeneratore da 4,5 Mw.

Between 2021 and 2022 the production plant was equipped with a new Continua+ pressing line, a post-combustor and a 4.5 Mw cogenerator.

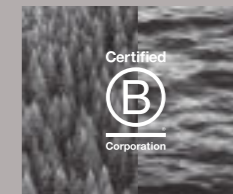

### 2025

Entra in funzione il nuovo stabilimento dedicato alle grandi lastre in gres porcellanato, un complesso produttivo tecnologicamente avanzato e progettato secondo i più elevati standard di sostenibilità.

The new plant dedicated to large-format porcelain stoneware slabs has entered into operation — a technologically advanced production facility designed according to the highest sustainability standards.

1950 Wenige Jahre nach Kriegsende sind der Unternehmer Romeo Giacobazzi und seine Frau Afra Fontana, ebenfalls Unternehmerin, aktiv am Wiederaufbau des wirtschaftlichen und sozialen Gefüges Italiens beteiligt, indem sie eines der ersten Unternehmen des Keramikdistrikts in der Emilia-Romagna gründen. - 1960 In wenigen Jahren steigt die Zahl der Beschäftigten auf 2.000 Personen, während die Boden- und Wandfliesenproduktion ein Volumen von über 20 Millionen Quadratmeter pro Jahr erreicht. - 1994 1994 ist Dante Giacobazzi, Sohn von Romeo und Afra, einer der Mitgründer der Gruppe Italgraniti. Im darauffolgenden Jahr wird das Werk in San Martino in Rio eingeweiht, in dem die Produktion von Feinsteinzeug vorgesehen ist. - 1998 In wenigen Jahren nimmt Italgraniti in Italien eine Führungsposition im Segment des technischen Feinsteinzeugs ein, und 1998 erwirbt es Impronta, eine historische Marke, die seit 1974 aktiv ist. - 2003 Mit der technischen Unterstützung von Sacmi entwirft das Forschungsteam der Italgraniti Group den ersten Prototyp der durchgehenden Presse für Großformate,

welcher 2003 in Betrieb genommen wird. - 2007 An der Seite von Dante Giacobazzi stehen seine Tochter Elisa und sein Schwiegersohn Francesco Maturo. Zusammen leiten sie das Unternehmen mit den gleichen Werten der Innovation und der unternehmerischen Kultur, die seit der Gründung ausschlaggebend waren. - 2015 Zwischen 2013 und 2015 wird das Werk in San Martino in Rio komplett erneuert und zur Erfüllung der Vorgaben für Industry 4.0 mit digitalen Technologien ausgestattet, die für die Automation der Produktionslinien, die Rationalisierung der Prozesse und die Reduzierung. - 2021 Zwischen 2021 und 2022 wurde das Werk mit einer neuen Continua+-Presslinie, einem Nachbrenner und einer 4,5-MW-Kraft-Wärme-Kopplungsanlage ausgestattet. - 2022 2022 veröffentlicht die Italgraniti Group die erste eigene Nachhaltigkeitsbilanz. - 2025 Das neue Werk für großformatige Feinsteinzeugplatten nimmt seinen Betrieb auf – ein technologisch hochmodernes Produktionszentrum, das gemäß den höchsten Nachhaltigkeitsstandards konzipiert wurde.

1950 Dans l'immédiat après-guerre, Romeo Giacobazzi et son épouse Afra Fontana, tous deux entrepreneurs, participent à la reconstruction du tissu économique et social de l'Italie en créant une des premières entreprises du district céramique d'Émilie-Romagne. - 1960 En quelques années, ils arrivent à employer 2 000 personnes et à produire plus de 20 millions de m<sup>2</sup> par an de carreaux pour revêtements de sol et muraux. - 1994 En 1994, Dante Giacobazzi, fils de Romeo et Afra, cofonde Italgraniti. L'année suivante, l'usine de San Martino in Rio, spécialisée dans la production de grès cérame, ouvre ses portes. - 1998 En quelques années, Italgraniti devient incontournable dans le secteur du grès cérame technique italien et, en 1998, elle acquiert Impronta, marque historique fondée en 1974. - 2003 Le service de Recherche d'Italgraniti conçoit, avec le support technique de Sacmi, le premier prototype de presse Continua pour les grands formats, qui entre en fonction en 2003. -

2007 Dante Giacobazzi est secondé par sa fille Elisa et son gendre Francesco Maturo. Ensemble, ils dirigent l'entreprise selon les mêmes valeurs immuables d'innovation et de culture entrepreneuriale. - 2015 Entre 2013 et 2015, l'usine de San Martino in Rio est entièrement rénovée et, dans une optique d'industrie 4.0, elle est équipée de technologies numériques dédiées à l'automatisation des lignes, à la rationalisation des processus et à la réduction des consommations. - 2021 Entre 2021 et 2022, l'usine de production est dotée d'une nouvelle ligne de presse Continua+, d'un brûleur de post-combustion et d'un cogénérateur de 4,5 MW. - 2022 En 2022, Italgraniti Group publie son premier Rapport de développement durable et obtient la certification B Corp. - 2025 La nouvelle usine dédiée aux grandes dalles en grès cérame entre en fonction : ce site de production de pointe est conçu selon les normes de durabilité les plus élevées.

## Sustainability, responsibility & interconnection.

Italgraniti Group è tra le maggiori aziende italiane produttrici di superfici in gres porcellanato per l'architettura e l'interior design che coniugano innovazione, estetica e sostenibilità. Dal 2022, il Gruppo è Società Benefit certificata B Corp e adotta un modello d'impresa che integra obiettivi economici, ambientali e sociali, generando valore condiviso lungo l'intera filiera. Tale impegno si traduce in investimenti strategici, utilizzo responsabile delle risorse e scelte coerenti con le aspettative di un mercato sempre più attento ai principi ESG. La profonda trasformazione industriale degli ultimi anni conferma la capacità di conciliare sviluppo tecnologico e tutela dell'ecosistema, consolidando la posizione dell'azienda come esempio autorevole di eccellenza produttiva e responsabilità etica.

Italgraniti Group is one of Italy's leading manufacturers of porcelain stoneware surfaces for architecture and interior design, combining innovation, aesthetics, and sustainability. Since 2022, the Group has been a B Corp certified Benefit Corporation, adopting a business model that integrates economic, environmental, and social objectives, generating shared value throughout the entire supply chain. This commitment translates into strategic investments, responsible use of resources, and choices consistent with the expectations of a market that is increasingly attentive to ESG principles. The profound industrial transformation of recent years confirms the company's ability to reconcile technological development with protection of the ecosystem, consolidating its position as an authoritative example of manufacturing excellence and ethical responsibility.

Die Italgraniti Group gehört zu den größten italienischen Herstellern von Feinsteinzeugoberflächen für Architektur und Innenarchitektur, die Innovation, Ästhetik und Nachhaltigkeit miteinander verbinden. Seit 2022 ist die Gruppe ein B-Corp-zertifiziertes Benefit-Unternehmen und verfolgt ein Geschäftsmodell, das wirtschaftliche, ökologische und soziale Ziele miteinander verbindet und so einen gemeinsamen Mehrwert entlang der gesamten Lieferkette schafft. Dieses Engagement zeigt sich in strategischen Investitionen, in einem verantwortungsvollen Umgang mit Ressourcen und in Entscheidungen, die den Erwartungen des Marktes entsprechen und zunehmend auf ESG-Prinzipien ausgerichtet sind. Der tiefgreifende industrielle Wandel der letzten Jahre bestätigt die Fähigkeit, technologische Entwicklung und Schutz des Ökosystems in Einklang zu bringen, und stärkt die Position des Unternehmens als maßgebliches Beispiel für Produktionskompetenz und ethische Verantwortung.

Italgraniti Group est l'un des principaux fabricants italiens de surfaces en grès cérame pour l'architecture et la décoration d'intérieur, alliant innovation, esthétique et durabilité. Depuis 2022, le groupe est une société certifiée B Corp et adopte un modèle d'entreprise qui intègre des objectifs économiques, environnementaux et sociaux, générant une valeur partagée tout au long de la chaîne d'approvisionnement. Cet engagement se traduit par des investissements stratégiques, une utilisation responsable des ressources et des choix cohérents avec les attentes d'un marché de plus en plus attentif aux principes ESG. La profonde transformation industrielle de ces dernières années confirme la capacité à concilier développement technologique et protection de l'écosystème, consolidant ainsi la position de l'entreprise comme un exemple autoritaire d'excellence productive et de responsabilité éthique.



Website





Total surface area  
30,000 m<sup>2</sup>

New slabs  
plant 5.0

Investments  
€60 million

### Innovative 5.0 production plant with the highest sustainability standards.

A inizio 2025 è entrato in funzione il nuovo stabilimento Italgraniti Group dedicato alla produzione di grandi lastre in gres porcellanato. Realizzato a San Martino in Rio (RE) con un investimento di oltre 60 milioni di euro, rappresenta un modello di industria 5.0 e parte di un hub produttivo-logistico altamente integrato e tecnologicamente avanzato. L'impianto si estende su circa 30.000 m<sup>2</sup>, adiacenti agli stabilimenti attivi dal 1994, e produce lastre fino al formato 160x320 cm, con spessori di 6, 12 e 20 mm. Progettato secondo i più elevati standard di sostenibilità del settore, il sito produttivo assicura benefici economici e ambientali, contribuendo allo sviluppo sostenibile del Gruppo e del territorio.

At the beginning of 2025, Italgraniti Group's new plant dedicated to the production of large porcelain stoneware slabs came into operation. Built in San Martino in Rio (RE) with an investment of over €60 million, it represents a model of Industry 5.0 and is part of a highly integrated and technologically advanced production and logistics hub. The plant covers approximately 30,000 m<sup>2</sup>, adjacent to the factories that have been in operation since 1994, and produces slabs up to 160x320 cm in size, with thicknesses of 6, 12, and 20 mm. Designed to the highest sustainability standards in the industry, the production site ensures economic and environmental benefits, contributing to the sustainable development of the Group and the local area.

Anfang 2025 wurde das neue Werk der Italgraniti Group für die Herstellung großformatiger Feinsteinzeugplatten in Betrieb genommen. Es wurde in San Martino in Rio (RE) mit einer Investition von über 60 Millionen Euro errichtet und gilt als Vorzeigeprojekt der Industrie 5.0 sowie als Teil eines hochintegrierten und technologisch fortschrittlichen Produktions- und Logistikzentrums. Die Anlage erstreckt sich über eine Fläche von rund 30.000 m<sup>2</sup>, angrenzend an die seit 1994 in Betrieb befindlichen Werke, und produziert Platten bis zu einer Größe von 160x320 cm mit Stärken von 6, 12 und 20 mm. Die Produktionsstätte wurde nach den höchsten Nachhaltigkeitsstandards der Branche konzipiert und gewährleistet wirtschaftliche und ökologische Vorteile, die zur nachhaltigen Entwicklung der Gruppe und der Region beitragen.

Début 2025, la nouvelle usine Italgraniti Group dédiée à la production de grandes dalles en grès cérame a été mise en service. Construite à San Martino in Rio (RE) grâce à un investissement de plus de 60 millions d'euros, elle représente un modèle d'industrie 5.0 et fait partie d'un pôle de production et de logistique hautement intégré et technologiquement avancé. L'usine s'étend sur environ 30 000 m<sup>2</sup>, à côté des usines en activité depuis 1994, et produit des dalles pouvant atteindre 160x320 cm, avec des épaisseurs de 6, 12 et 20 mm. Conçu selon les normes de durabilité les plus élevées du secteur, le site de production garantit des avantages économiques et environnementaux, contribuant ainsi au développement durable du groupe et du territoire.



Website

## A sustainable and energy-independent production model.

Il nuovo stabilimento è un modello sostenibile ed efficiente, capace di unire tecnologia avanzata e rispetto ambientale. Sarà completamente autosufficiente dal punto di vista elettrico grazie a un impianto fotovoltaico, attualmente in fase di completamento, che genererà 3,4 milioni di kWh/anno, evitando l'emissione di 1.800 tonnellate di CO<sub>2</sub>, pari all'assorbimento di un bosco di 82 mila alberi. Dalla struttura agli impianti, fino al packaging e all'illuminazione ad alta efficienza, ogni componente è stato progettato con l'obiettivo di valorizzare un ciclo produttivo altamente virtuoso, caratterizzato da un uso ridotto delle materie prime e dal recupero efficiente di tutte le risorse disponibili: acqua, energia termica, scarti crudi e cotti.

The new plant is a sustainable and efficient model, combining advanced technology and environmental respect. It will be completely self-sufficient in terms of electricity thanks to a photovoltaic system, currently being completed, which will generate 3.4 million kWh/year, avoiding the emission of 1,800 tons of CO<sub>2</sub>, equivalent to the absorption of a forest of 82,000 trees. From the structure to the systems, to the packaging and high-efficiency lighting, every component has been designed with the aim of enhancing a highly virtuous production cycle, characterized by reduced use of raw materials and efficient recovery of all available resources: water, thermal energy, raw and fired waste.

Das neue Werk ist ein nachhaltiges und effizientes Modell, das fortschrittliche Technologie mit Umweltverträglichkeit vereint. Es wird dank einer derzeit fertiggestellten Photovoltaikanlage vollständig energieautark sein, die jährlich 3,4 Millionen kWh erzeugt und so den Ausstoß von 1.800 Tonnen CO<sub>2</sub> vermeidet – was dem Absorptionsvermögen eines Waldes von 82.000 Bäumen entspricht. Von der Gebäudestruktur über die Anlagen bis hin zur Verpackung und zur energieeffizienten Beleuchtung wurde jede Komponente mit dem Ziel entwickelt, einen hochgradig nachhaltigen Produktionskreislauf zu fördern. Dieser zeichnet sich durch einen reduzierten Einsatz von Rohstoffen und durch die effiziente Rückgewinnung aller verfügbaren Ressourcen aus: Wasser, thermische Energie sowie Roh- und Brennabfälle.

La nouvelle usine est un modèle durable et efficace, capable d'allier technologie de pointe et respect de l'environnement. Elle sera entièrement autonome sur le plan électrique grâce à une installation photovoltaïque, actuellement en cours d'achèvement, qui produira 3,4 millions de kWh/an, évitant ainsi l'émission de 1 800 tonnes de CO<sub>2</sub>, soit l'absorption d'une forêt de 82 000 arbres. De la structure aux installations, en passant par les emballages et l'éclairage à haute efficacité, chaque composant a été conçu dans le but de valoriser un cycle de production hautement vertueux, caractérisé par une utilisation réduite des matières premières et une récupération efficace de toutes les ressources disponibles : eau, énergie thermique, déchets crus et cuits.

Photovoltaic system  
**3.4 million  
kWh/year**

CO<sub>2</sub> reduction  
**1,800  
t/year**

Equal to the absorption of  
**82 thousand  
trees**



# Circularity & recycling

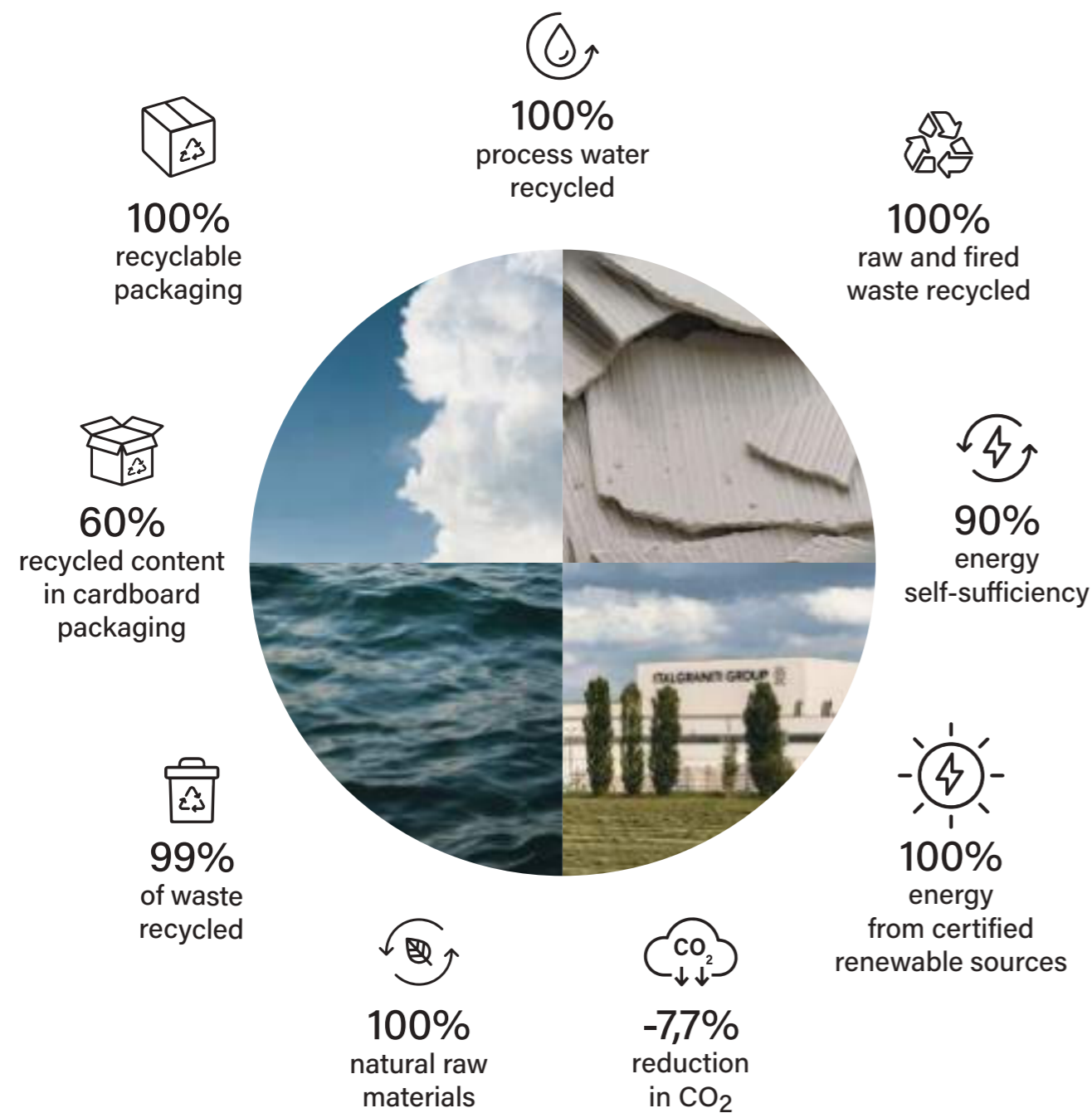

## Italgraniti Group embraces reuse, reduction, and circularity for sustainable growth.

Il Gruppo si impegna, nell'ottica della riduzione del cambiamento climatico, a sviluppare prodotti e processi che minimizzino l'impatto ambientale. L'impegno si concretizza nell'adozione di pratiche responsabili lungo la catena di approvvigionamento, nell'impiego di materiali riciclabili e nell'utilizzo di tecnologie in grado di ridurre le emissioni di carbonio e gli effetti negativi sull'ecosistema. La gestione delle materie prime rappresenta un elemento fondamentale di questo approccio: i materiali impiegati sono naturali, ampiamente disponibili sulla superficie del pianeta, non costituiscono fonte di tensioni geopolitiche e provengono da cave autorizzate, soggette a piani di riqualificazione ambientale al termine delle attività estrattive.

The Group is committed to developing products and processes that minimize environmental impact with a view to reducing climate change. This commitment is reflected in the adoption of responsible practices throughout the supply chain, the use of recyclable materials, and the use of technologies that reduce carbon emissions and negative effects on the ecosystem. The management of raw materials is a fundamental part of this approach: the materials used are natural, widely available on the planet's surface, do not constitute a source of geopolitical tension, and come from authorized quarries that are subject to environmental redevelopment plans at the end of their mining activities.

Im Hinblick auf die Eindämmung des Klimawandels verpflichtet sich die Gruppe, Produkte und Prozesse zu entwickeln, die die Auswirkungen auf die Umwelt minimieren. Dieses Engagement konkretisiert sich in der Einführung verantwortungsbewusster Praktiken entlang der gesamten Lieferkette, in der Verwendung recycelbarer Materialien und im Einsatz von Technologien, die den CO<sub>2</sub>-Ausstoß sowie die negativen Auswirkungen auf das Ökosystem reduzieren. Die Verwaltung der Rohstoffe ist ein wesentlicher Bestandteil dieses Ansatzes: Die verwendeten Materialien sind natürlicher Herkunft, auf der Erde reichlich vorhanden, verursachen keine geopolitischen Spannungen und stammen aus zugelassenen Steinbrüchen, die nach Abschluss der Abbauarbeiten einer Umweltsanierung unterzogen werden.

Dans le but de réduire le changement climatique, le Groupe s'engage à développer des produits et des processus qui minimisent l'impact environnemental. Cet engagement se traduit par l'adoption de pratiques responsables tout au long de la chaîne d'approvisionnement, l'utilisation de matériaux recyclables et le recours à des technologies capables de réduire les émissions de carbone et les effets négatifs sur l'écosystème. La gestion des matières premières est un élément fondamental de cette approche : les matériaux utilisés sont naturels, largement disponibles à la surface de la planète, ne constituent pas une source de tensions géopolitiques et proviennent de carrières autorisées, soumises à des plans de réhabilitation environnementale à la fin des activités d'extraction.

## A new paradigm in ceramic surfaces.

Le superfici Italgraniti definiscono un nuovo paradigma di performance e qualità. Alla base vi è un modello produttivo che integra innovazione tecnologica ed efficienza dei processi, garantendo standard sempre più elevati. Tra le soluzioni più avanzate spicca l'innovativo forno di cottura lungo 230 metri, che assicura un controllo termico estremamente preciso, riducendo i tensionamenti interni delle lastre e migliorando uniformità, resistenza e sicurezza. Il risultato è una superficie ceramica ad alte prestazioni, autentica espressione dell'evoluzione tecnologica e produttiva di Italgraniti.

Italgraniti surfaces define a new paradigm of performance and quality. At the heart of this is a production model that integrates technological innovation and process efficiency, guaranteeing ever higher standards. Among the most advanced solutions is the innovative 230-meter-long firing kiln, which ensures extremely precise temperature control, reducing internal stresses in the slabs and improving uniformity, resistance, and safety. The result is a high-performance ceramic surface, an authentic expression of Italgraniti's technological and production evolution.

Die Oberflächen von Italgraniti setzen neue Maßstäbe in Sachen Leistung und Qualität. Grundlage dafür ist ein Produktionsmodell, das technologische Innovation und Prozesseffizienz miteinander verbindet und immer höhere Standards garantiert. Zu den fortschrittlichsten Lösungen zählt der innovative 230 Meter lange Brennofen, der eine äußerst präzise Temperaturregelung gewährleistet, die inneren Spannungen der Platten reduziert und deren Gleichmäßigkeit, Widerstandsfähigkeit und Sicherheit verbessert. Das Ergebnis ist eine hochleistungsfähige Keramikoberfläche, die ein authentischer Ausdruck der technologischen und produktiven Entwicklung von Italgraniti ist.

Les surfaces Italgraniti définissent un nouveau paradigme en matière de performances et de qualité. À la base, il y a un modèle de production qui intègre innovation technologique et efficacité des processus, garantissant des standards toujours plus élevés. Parmi les solutions les plus avancées, on remarque le four de cuisson innovant de 230 mètres de long, qui assure un contrôle thermique extrêmement précis, réduisant les tensions internes des dalles et améliorant l'uniformité, la résistance et la sécurité. Le résultat est une surface céramique haute performance, expression authentique de l'évolution technologique et productive d'Italgraniti.



Website



**230-Meter**  
Hydrogen-Ready  
efficient kiln

**Balanced firing cycles**  
ensure tension free-slabs  
eliminating internal stresses





AI  
quality  
control

Cutting-Edge  
technology

Advanced  
digital decoration

## Artificial intelligence at the heart of a technological evolution that is redefining the ceramic industry.

Italgraniti integra l'intelligenza artificiale nei propri processi produttivi, raggiungendo nuovi standard di precisione, efficienza e qualità estetica. All'interno della tecnologia brevettata RealUp®, l'AI affianca i tecnici nel perfezionare il matching tra grafica e struttura, restituendo superfici di straordinaria matericità e profondità visiva. Nel controllo qualità, un avanzato sistema di visione ottica intelligente impiega l'intelligenza artificiale per rilevare anomalie inferiori al millimetro, apprendere automaticamente dagli errori e correggerli in tempo reale. Un'evoluzione tecnologica che conferma Italgraniti tra i protagonisti più innovativi dell'industria ceramica.

Italgraniti integrates artificial intelligence into its production processes, achieving new standards of precision, efficiency, and aesthetic quality. Within the patented RealUp® technology, AI assists technicians in perfecting the matching between graphics and structure, resulting in surfaces with extraordinary texture and visual depth. In quality control, an advanced intelligent optical vision system uses artificial intelligence to detect anomalies smaller than a millimeter, automatically learning from errors and correcting them in real time. This technological evolution confirms Italgraniti as one of the most innovative players in the ceramic industry.

Italgraniti integriert künstliche Intelligenz in seine Produktionsprozesse und erreicht damit neue Standards in Sachen Präzision, Effizienz und ästhetischer Qualität. Im Rahmen der patentierten RealUp®-Technologie unterstützt die KI die Techniker dabei, die Übereinstimmung zwischen Grafik und Struktur zu perfektionieren, wodurch Oberflächen mit außergewöhnlicher Materialität und visueller Tiefe entstehen. In der Qualitätskontrolle nutzt ein fortschrittliches intelligentes optisches Bildverarbeitungssystem künstliche Intelligenz, um Abweichungen von weniger als einem Millimeter zu erkennen, automatisch aus Fehlern zu lernen und diese in Echtzeit zu korrigieren. Eine technologische Entwicklung, die Italgraniti als einen der innovativsten Akteure der Keramikindustrie bestätigt.

Italgraniti intègre l'intelligence artificielle dans ses processus de production, atteignant ainsi de nouveaux standards de précision, d'efficacité et de qualité esthétique. Au sein de la technologie brevetée RealUp®, l'IA aide les techniciens à perfectionner l'harmonisation entre le graphique et la structure, offrant ainsi des surfaces d'une matérialité et d'une profondeur visuelle extraordinaires. Dans le domaine du contrôle qualité, un système avancé de vision optique intelligente utilise l'intelligence artificielle pour détecter des anomalies inférieures au millimètre, apprendre automatiquement des erreurs et les corriger en temps réel. Une évolution technologique qui confirme Italgraniti parmi les acteurs les plus innovants de l'industrie céramique.

## RealUp®: new sensory experience on a large scale.

L'innovativa tecnologia RealUp® rappresenta una delle più avanzate espressioni dell'evoluzione ceramica Italgraniti. Grazie a un sofisticato sistema digitale, due tecnologie di ultima generazione lavorano in perfetta sinergia, allineando con estrema precisione grafica e tridimensionalità: il dato cromatico e quello materico coincidono senza margine d'errore, generando superfici di straordinario realismo e profondità. Questa esclusiva innovazione si estende oggi anche alle grandi lastre Mega®: applicata su larga scala, la tecnologia RealUp® amplifica l'autenticità della superficie, esaltando la continuità estetica e le potenzialità progettuali delle collezioni Italgraniti.

The innovative RealUp® technology represents one of the most advanced expressions of Italgraniti's ceramic evolution. Thanks to a sophisticated digital system, two latest-generation technologies work in perfect synergy, aligning graphics and three-dimensionality with extreme precision: color and material data coincide without margin for error, generating surfaces of extraordinary realism and depth. This exclusive innovation now also extends to Mega® large slabs: applied on a large scale, RealUp® technology amplifies the authenticity of the surface, enhancing the aesthetic continuity and design potential of Italgraniti collections.



Website

Die innovative RealUp®-Technologie ist einer der fortschrittlichsten Ausdrucksformen der keramischen Entwicklung von Italgraniti. Dank eines ausgeklügelten digitalen Systems arbeiten zwei Technologien der neuesten Generation in perfekter Synergie zusammen und stimmen Grafik und Dreidimensionalität mit äußerster Präzision aufeinander ab: Die Farb- und Materialdaten stimmen ohne Fehlerquote überein und erzeugen Oberflächen von außergewöhnlichem Realismus und Tiefe. Diese exklusive Innovation erstreckt sich heute auch auf die großen Mega®-Platten: In großem Maßstab angewendet, verstärkt die RealUp®-Technologie die Authentizität der Oberfläche und unterstreicht die ästhetische Kontinuität und das Gestaltungspotenzial der Italgraniti-Kollektionen.

La technologie innovante RealUp® représente l'une des expressions les plus avancées de l'évolution céramique d'Italgraniti. Grâce à un système numérique sophistiqué, deux technologies de dernière génération fonctionnent en parfaite synergie, alignant avec une extrême précision le graphisme et la tridimensionnalité : les données chromatiques et matérielles coïncident sans marge d'erreur, générant des surfaces d'un réalisme et d'une profondeur extraordinaires. Cette innovation exclusive s'étend aujourd'hui également aux grandes dalles Mega® : appliquée à grande échelle, la technologie RealUp® amplifie l'authenticité de la surface, mettant en valeur la continuité esthétique et le potentiel de conception des collections Italgraniti.



RealUp®  
Innovative technology

REAL UP® FOR  
**MEGA**



**StrideUp®**  
Innovative technology

**StrideUp®: safe surfaces that are pleasant to the touch and easy to clean.**

StrideUp® è la tecnologia che combina un'elevata resistenza allo scivolamento con una morbidezza di superficie unica. Garantisce un alto coefficiente di attrito dinamico, indispensabile per pavimentare aree a intenso calpestio o contesti in cui le normative edilizie richiedono specifiche performance antiscivolo, senza tuttavia rinunciare al comfort tattile tipico delle superfici da interni. StrideUp® rappresenta un'innovazione che amplia la versatilità del gres porcellanato, stabilendo nuovi standard prestazionali e qualitativi che si traducono in un maggiore valore progettuale e in un ampliamento delle possibilità applicative.

StrideUp® is a technology that combines high slip resistance with a unique surface softness. It guarantees a high dynamic friction coefficient, which is essential for flooring in high-traffic areas or contexts where building regulations require specific anti-slip performance, without sacrificing the tactile comfort typical of interior surfaces. StrideUp® is an innovation that expands the versatility of porcelain stoneware, setting new performance and quality standards that translate into greater design value and a wider range of application possibilities.

StrideUp® ist eine Technologie, die hohe Rutschfestigkeit mit einer einzigartigen Oberflächenweicheit verbindet. Sie gewährleistet einen hohen dynamischen Reibungskoeffizienten, der für Bodenbeläge in stark frequentierten Bereichen oder in Umgebungen, in denen die Bauvorschriften spezifische rutschhemmende Eigenschaften verlangen, unerlässlich ist – ohne dabei auf den für Innenflächen typischen taktilen Komfort zu verzichten. StrideUp® ist eine Innovation, die die Vielseitigkeit von Feinsteinzeug erweitert und neue Leistungs- und Qualitätsstandards setzt, die sich in einem höheren Gestaltungswert und einer Erweiterung der Anwendungsmöglichkeiten widerspiegeln.

StrideUp® est une technologie qui combine une résistance élevée au glissement et une douceur de surface unique. Elle garantit un coefficient de frottement dynamique élevé, indispensable pour le revêtement de sols dans des zones à fort passage ou dans des contextes où les normes de construction exigent des performances antidérapantes spécifiques, sans pour autant renoncer au confort tactile typique des surfaces intérieures. StrideUp® représente une innovation qui élargit la polyvalence du grès cérame, établissant de nouvelles normes de performance et de qualité qui se traduisent par une plus grande valeur conceptuelle et un élargissement des possibilités d'application.

## Sana®: antimicrobial surfaces for healthy and safe environments.

L'ultima tecnologia messa a punto da Italgraniti si chiama Sana® e sfrutta le proprietà antimicrobico degli ioni d'argento per eliminare fino al 99,9% dei batteri presenti sulla superficie ceramica e prevenirne la formazione. Questa innovazione si basa su un additivo aggiunto all'impasto ceramico prima della cottura, che diventa parte integrante del prodotto senza alterarne le qualità estetiche né le performance. Sana® rappresenta un ulteriore passo avanti nell'evoluzione dei prodotti di Italgraniti Group perché contribuisce a elevare la qualità dei contesti abitativi e il valore degli edifici contemporanei.

The latest technology developed by Italgraniti is called Sana® and exploits the antimicrobial properties of silver ions to eliminate up to 99.9% of bacteria present on ceramic surfaces and prevent their formation. This innovation is based on an additive added to the ceramic mixture before firing, which becomes an integral part of the product without altering its aesthetic qualities or performance. Sana® represents a further step forward in the evolution of Italgraniti Group products because it contributes to raising the quality of living environments and the value of contemporary buildings.

Die neueste von Italgraniti entwickelte Technologie heißt Sana® und nutzt die antimikrobiell Eigenschaften von Silberionen, um bis zu 99,9 % der auf der Keramikoberfläche vorhandenen Bakterien zu beseitigen und deren Neubildung zu verhindern. Diese Innovation basiert auf einem Zusatzstoff, der der Keramikmasse vor dem Brennen beigemischt wird und dadurch zu einem integralen Bestandteil des Produkts wird, ohne dessen ästhetische Eigenschaften oder Leistungsmerkmale zu verändern. Sana® stellt einen weiteren Fortschritt in der Produktentwicklung der Italgraniti Group dar, da es zur Verbesserung der Wohnraumqualität und zur Aufwertung zeitgenössischer Architektur beiträgt.

La dernière technologie mise au point par Italgraniti s'appelle Sana® et exploite les propriétés antimicrobien des ions d'argent pour éliminer jusqu'à 99,9 % des bactéries présentes à la surface de la céramique et empêcher leur formation. Cette innovation repose sur un additif ajouté au mélange céramique avant la cuisson, qui devient partie intégrante du produit sans en altérer les qualités esthétiques ni les performances. Sana® représente une nouvelle avancée dans l'évolution des produits du groupe Italgraniti, car elle contribue à améliorer la qualité des environnements résidentiels et la valeur des bâtiments contemporains.



The advertisement features a central image of a black microscope on a light-colored surface. To the left of the microscope are two glass slides, each with a circular area in the center. Above the microscope, the Sana® logo is displayed, consisting of a stylized diamond shape followed by the word 'sana' in lowercase. Below the logo, the text 'THE ANTIMICROBIAL TECHNOLOGY' is written in all caps. At the bottom of the image, two columns of text are present: 'Active 24/7, even in the dark' on the left and 'Silver ions active against bacteria' on the right.

**sana®**  
THE ANTIMICROBIAL TECHNOLOGY

Active 24/7,  
even in the dark

Silver ions  
active against bacteria



**Mega® large slabs: excellence in design and architectural innovation.**

Le grandi lastre 120x280x0,6 cm svolgono un ruolo sempre più significativo in edilizia e in architettura, sia nelle nuove costruzioni sia negli interventi di ristrutturazione. Il programma di superfici Mega® offre ai progettisti la possibilità di utilizzare un grande formato che coniuga valore estetico, spessore ridotto, elevata resistenza e stabilità. Le caratteristiche tecniche e le proprietà cromatiche delle lastre restano inalterate nel tempo, garantendo durabilità e prestazioni costanti in qualsiasi condizione ambientale. Realizzate attraverso processi produttivi a basso impatto, le superfici Mega® contribuiscono all'ottenimento dei crediti ambientali nei più avanzati progetti di Green Building.

Large 120x280x0.6 cm slabs are playing an increasingly significant role in construction and architecture, both in new buildings and in renovation projects. The Mega® surface range offers designers the possibility of using a large format that combines aesthetic value, reduced thickness, high resistance, and stability. The technical characteristics and chromatic properties of the slabs remain unchanged over time, ensuring durability and consistent performance in all environmental conditions. Manufactured using low-impact production processes, Mega® surfaces contribute to obtaining environmental credits in the most advanced Green Building projects.

Die großformatigen Platten im Format 120x280x0,6 cm spielen im Bauwesen und in der Architektur eine zunehmend wichtige Rolle – sowohl im Neubau als auch bei Renovierungsprojekten. Das Oberflächenprogramm Mega® bietet Planern die Möglichkeit, ein großes Format zu verwenden, das ästhetischen Wert, geringe Stärke, hohe Widerstandsfähigkeit und außergewöhnliche Stabilität vereint. Die technischen Eigenschaften und die Farbbeständigkeit der Platten bleiben im Laufe der Zeit unverändert und gewährleisten Langlebigkeit sowie konstante Leistungsfähigkeit unter allen Einsatzbedingungen. Die Mega®-Oberflächen werden in umweltfreundlichen Produktionsprozessen hergestellt und tragen dazu bei, in anspruchsvollen Green-Building-Projekten wertvolle Umweltpunkte zu erzielen.

Les grandes dalles 120x280x0,6 cm jouent un rôle de plus en plus important dans le bâtiment et l'architecture, tant dans les nouvelles constructions que dans les rénovations. La gamme de surfaces Mega® offre aux concepteurs la possibilité d'utiliser un grand format qui allie esthétique, faible épaisseur, haute résistance et stabilité. Les caractéristiques techniques et les propriétés chromatiques des dalles restent inchangées dans le temps, garantissant une durabilité et des performances constantes dans toutes les conditions environnementales. Réalisées à l'aide de processus de production à faible impact, les surfaces Mega® contribuent à l'obtention de crédits environnementaux dans les projets de construction écologique les plus avancés.



Download Catalogue

**Mega®: a sustainable design choice with a reduced environmental impact.**

Il gres Italgraniti ultrasottile rappresenta una scelta progettuale sostenibile e ad alto valore tecnico. Pur mantenendo le stesse performance delle superfici a spessore tradizionale, le lastre Mega® richiedono un minore impiego di materie prime ed energia nei processi produttivi, contribuendo così a ridurre l'impatto ambientale complessivo. Anche la fase logistica trae vantaggio da queste caratteristiche: il ridotto spessore permette di ottimizzare il trasporto e di diminuire le emissioni di CO<sub>2</sub>. Sul piano applicativo, le lastre consentono di rinnovare pavimenti e rivestimenti senza la necessità di demolire le superfici esistenti, con una significativa riduzione dei rifiuti di cantiere.

Italgraniti ultra-thin stoneware is a sustainable design choice with high technical value. While maintaining the same performance as traditional thickness surfaces, Mega® slabs require less raw materials and energy in the production process, thus helping to reduce the overall environmental impact. The logistics phase also benefits from these characteristics: the reduced thickness optimizes transport and reduces CO<sub>2</sub> emissions. In terms of application, the slabs allow floors and wall coverings to be renovated without the need to demolish existing surfaces, significantly reducing construction waste.

Das ultradünne Feinsteinzeug von Italgraniti ist eine nachhaltige Wahl mit hohem technischem Wert. Bei gleicher Leistungsfähigkeit wie Oberflächen mit herkömmlicher Stärke benötigen die Mega®-Platten weniger Rohstoffe und Energie in den Produktionsprozessen und tragen so zur Verringerung der Gesamtumweltbelastung bei. Auch die Logistik profitiert von diesen Eigenschaften: Die reduzierte Stärke ermöglicht eine Optimierung des Transports und eine Verringerung der CO<sub>2</sub>-Emissionen. In der Anwendung ermöglichen die Platten die Erneuerung von Fußböden und Verkleidungen, ohne dass die bestehenden Oberflächen abgerissen werden müssen, was zu einer erheblichen Reduzierung des Bauabfalls führt.

Le grès Italgraniti ultrafin représente un choix durable et à haute valeur technique. Tout en conservant les mêmes performances que les surfaces d'épaisseur traditionnelle, les dalles Mega® nécessitent moins de matières premières et d'énergie dans les processus de production, contribuant ainsi à réduire l'impact environnemental global. La phase logistique bénéficie également de ces caractéristiques: l'épaisseur réduite permet d'optimiser le transport et de diminuer les émissions de CO<sub>2</sub>. Sur le plan de l'application, les dalles permettent de rénover les sols et les revêtements sans avoir à démolir les surfaces existantes, ce qui réduit considérablement les déchets de chantier.

**MEGA**<sup>®</sup>  
INNOVATIVE SLABS

<b>-35%</b> water consumption	<b>-33%</b> raw materials	<b>-30%</b> energy consumption	<b>-30%</b> CO <sub>2</sub> emissions
-------------------------------------	---------------------------------	--------------------------------------	---

I dati fanno riferimento a un prodotto a spessore sottile, confrontato con un grès porcellanato di spessore tradizionale.  
The data refer to a thin-thickness product compared to a traditional-thickness porcelain stoneware.



**ITAL**<sup>®</sup>  
**STONE**

**Italstone<sup>®</sup>, large slabs up to 160x320 cm,  
with thicknesses of 1.2 and 2 cm.**

Italstone<sup>®</sup> è il progetto di Italgraniti dedicato alle grandi lastre in gres porcellanato, con formati fino a 160x320 cm. I prodotti nascono da un attento studio dei marmi e delle pietre più preziose disponibili in natura, espressione di un sistema produttivo tecnologicamente evoluto e sostenibile. Superfici che uniscono rigore tecnico, materie prime purissime e finiture impeccabili in una soluzione ceramica versatile, dalle performance eccezionali. Affidabili e dal grande potenziale espressivo, sono pensate per chi immagina nuove visioni dell'abitare contemporaneo.

Italstone<sup>®</sup> is Italgraniti's project dedicated to large porcelain stoneware slabs, with sizes up to 160x320 cm. The products are the result of careful study of the most precious marbles and stones available in nature, expressing a technologically advanced and sustainable production system. Surfaces that combine technical rigor, the purest raw materials, and impeccable finishes in a versatile ceramic solution with exceptional performance. Reliable and with great expressive potential, they are designed for those who imagine new visions of contemporary living.



Italstone<sup>®</sup> ist das Projekt von Italgraniti, das sich großen Feinsteinzeugplatten mit Formaten bis zu 160x320 cm widmet. Die Produkte sind das Ergebnis einer sorgfältigen Untersuchung der wertvollsten Marmor- und Steinsorten, die in der Natur vorkommen, und Ausdruck eines technologisch fortschrittlichen und nachhaltigen Produktionssystems. Oberflächen, die technische Präzision, reinste Rohstoffe und makellose Oberflächen in einer vielseitigen Keramiklösung mit außergewöhnlicher Leistungsfähigkeit vereinen. Zuverlässig und mit großem Ausdruckspotenzial, sind sie für diejenigen gedacht, die neue Visionen des zeitgenössischen Wohnens entwickeln.

Italstone<sup>®</sup> est le projet d'Italgraniti dédié aux grandes dalles en grès cérame, avec des formats allant jusqu'à 160x320 cm. Les produits sont le fruit d'une étude attentive des marbres et des pierres les plus précieux disponibles dans la nature, expression d'un système de production technologiquement avancé et durable. Des surfaces qui allient rigueur technique, matières premières très pures et finitions impeccables dans une solution céramique polyvalente aux performances exceptionnelles. Fiables et dotées d'un grand potentiel expressif, elles sont conçues pour ceux qui imaginent de nouvelles visions de l'habitat contemporain.



Website

**Open®: outdoor surfaces powered by innovative StrideUp20® technology.**

Open® è il progetto di superfici per esterno in gres porcellanato tecnico con spessore extra di 2 cm: una selezione di materiali ineguagliabili dedicati al landscape design e agli spazi outdoor contemporanei. Grazie all'innovativa tecnologia StrideUp 20®, queste superfici garantiscono un altissimo coefficiente di attrito dinamico (R11 A+B+C) senza rinunciare a una piacevole morbidezza al tatto, paragonabile a quella dei pavimenti da interno. StrideUp 20® rappresenta una nuova generazione di superfici che coniuga sicurezza, comfort e facilità di pulizia, mantenendo nel tempo prestazioni costanti e un'estetica impeccabile.

Open® is a range of technical porcelain stoneware surfaces for outdoor use with an extra thickness of 2 cm: a selection of unparalleled materials dedicated to landscape design and contemporary outdoor spaces. Thanks to the innovative StrideUp 20® technology, these surfaces guarantee a very high dynamic friction coefficient (R11 A+B+C) without sacrificing a pleasant softness to the touch, comparable to that of indoor flooring. StrideUp 20® represents a new generation of surfaces that combine safety, comfort, and ease of cleaning, maintaining consistent performance and impeccable aesthetics over time.

Open® ist das Projekt für Außenflächen aus technischem Feinsteinzeug mit einer zusätzlichen Stärke von 2 cm: eine Auswahl unvergleichlicher Materialien für die Landschaftsgestaltung und zeitgemäße Außenbereiche. Dank der innovativen StrideUp 20®-Technologie garantieren diese Oberflächen einen sehr hohen dynamischen Reibungskoeffizienten (R11 A+B+C), ohne dabei auf eine angenehme Weichheit zu verzichten, die mit der von Innenböden vergleichbar ist. StrideUp 20® steht für eine neue Generation von Oberflächen, die Sicherheit, Komfort und einfache Reinigung vereinen und dabei eine konstante Leistung und eine makellose Ästhetik über lange Zeit gewährleisten.

Open® est le projet de surfaces extérieures en grès cérame technique d'une épaisseur supplémentaire de 2 cm : une sélection de matériaux incomparables dédiés à l'aménagement paysager et aux espaces extérieurs contemporains. Grâce à la technologie innovante StrideUp 20®, ces surfaces garantissent un coefficient de frottement dynamique très élevé (R11 A+B+C) sans renoncer à un toucher agréable, comparable à celui des sols intérieurs. StrideUp 20® représente une nouvelle génération de surfaces qui allient sécurité, confort et facilité de nettoyage, tout en conservant des performances constantes et une esthétique impeccable dans le temps.



Download  
Catalogue

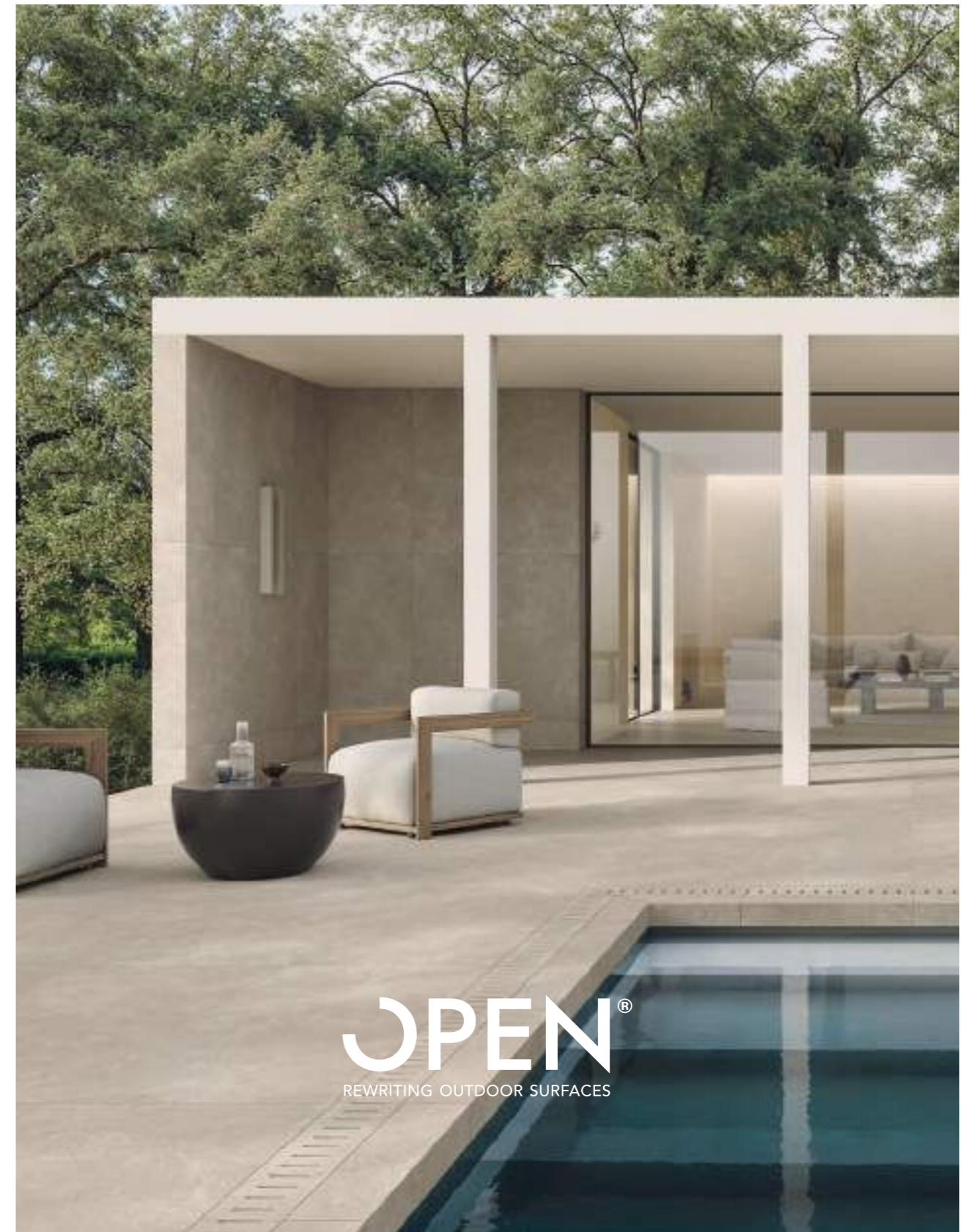

**StrideUp 20®**  
Innovative technology



**New dimensions: 120x120x0.9 cm with a non-slip surface.**

Italgraniti introduce un'importante novità nell'ambito delle superfici per l'outdoor: il formato 120x120 cm in spessore 9 mm. Una soluzione inedita per le applicazioni esterne, che amplia le possibilità progettuali grazie allo spessore tradizionale perfettamente coordinato con le superfici interne. I moduli 120x120 antislip, integrano la tecnologia StrideUp®, che combina un'elevata resistenza allo scivolamento con una matericità sorprendentemente morbida al tatto. Con questa innovazione Italgraniti rafforza il proprio ruolo di riferimento nello sviluppo di soluzioni ceramiche evolute per l'architettura contemporanea.

Italgraniti introduces an important innovation in the field of outdoor surfaces: the 120x120 cm format in 9 mm thickness. A brand new solution for outdoor applications, which expands design possibilities thanks to its traditional thickness, perfectly coordinated with indoor surfaces. The 120x120 anti-slip modules incorporate StrideUp® technology, which combines high slip resistance with a surprisingly soft texture. With this innovation, Italgraniti reinforces its role as a leader in the development of advanced ceramic solutions for contemporary architecture.

Italgraniti führt eine wichtige Neuheit im Bereich der Oberflächen für den Außenbereich ein: das Format 120x120 cm in einer Stärke von 9 mm. Eine neuartige Lösung für Außenanwendungen, die dank der traditionellen Stärke, die perfekt auf die Innenflächen abgestimmt ist, die Gestaltungsmöglichkeiten erweitert. Die rutschhemmenden Module 120x120 sind mit der StrideUp®-Technologie ausgestattet, die eine hohe Rutschfestigkeit mit einer überraschend weichen Haptik verbindet. Mit dieser Innovation festigt Italgraniti seine Vorreiterrolle bei der Entwicklung fortschrittlicher Keramiklösungen für die zeitgenössische Architektur.

Italgraniti présente une nouveauté importante dans le domaine des surfaces pour l'extérieur : le format 120x120 cm d'une épaisseur de 9 mm. Une solution inédite pour les applications extérieures, qui élargit les possibilités de conception grâce à son épaisseur traditionnelle parfaitement coordonnée avec les surfaces intérieures. Les modules antidérapants 120x120 intègrent la technologie StrideUp®, qui combine une résistance élevée au glissement avec une texture étonnamment douce au toucher. Avec cette innovation, Italgraniti renforce son rôle de référence dans le développement de solutions céramiques avancées pour l'architecture contemporaine.

**LOOM, furniture and design components.  
Design Andrea Parisio & Giuseppe Pezzano**

LOOM è il brand di arredi e complementi in ceramica per la stanza da bagno, firmato dagli architetti e art director Andrea Parisio e Giuseppe Pezzano. Un progetto innovativo che si caratterizza per la possibilità di personalizzare gli arredi con le lastre di tutte le collezioni Mega® a spessore 6 mm di Italgraniti. Con un effetto ogni volta originale e sorprendente di continuità materica fra elementi di arredo, pareti e pavimenti, secondo un concetto dell'ambiente bagno come oasi avvolgente di benessere.

LOOM is the ceramic bathroom furnishings and accessories brand styled by architects and art directors Andrea Parisio and Giuseppe Pezzano. This innovative project enables clients to customise furnishings with slabs from all the Italgraniti Mega® collections in 6 mm thickness. It provides a stunning, constantly original effect of continuity of material across furnishings, walls and floors, transforming bathrooms into enticing oases of wellbeing.

LOOM ist die Marke für Keramikmöbel und -accessoires für das Badezimmer, entworfen von den Architekten und Artdirektoren Andrea Parisio und Giuseppe Pezzano. Ein innovatives Projekt, das sich durch die Möglichkeit auszeichnet, die Möbel mit den 6 mm starken Platten aller Mega®-Kollektionen von Italgraniti individuell zu gestalten. Mit einem stets originellen und überraschenden Effekt der materiellen Kontinuität zwischen Einrichtungselementen, Wänden und Böden, gemäß einem Konzept des Badezimmers als einhüllende Oase des Wohlbefindens.

LOOM est la marque de mobilier et d'accessoires en céramique pour la salle de bains, signée par les architectes et directeurs artistiques Andrea Parisio et Giuseppe Pezzano. Un projet innovant qui se caractérise par la possibilité de personnaliser le mobilier avec les dalles de toutes les collections Mega® de 6 mm d'épaisseur d'Italgraniti. Avec un effet toujours original et surprenant de continuité matérielle entre les éléments d'ameublement, les murs et les sols, selon un concept de la salle de bains comme une oasis enveloppante de bien-être.



Website





LOOM  
BY ITALGRANITI

## New elements: functionality and material harmony.

Nuovi elementi d'arredo ampliano e completano il progetto LOOM: piani con lavabi integrati e d'appoggio, mensole e piatti doccia, ogni elemento è progettato per garantire coerenza stilistica e materica in un perfetto equilibrio tra funzionalità e design. L'intero progetto si sviluppa all'insegna della massima coordinazione con le grandi lastre Mega®, dando vita a un dialogo continuo tra arredi, rivestimenti e pavimenti che esalta la forza espressiva del gres porcellanato Italgraniti.

New furnishing elements expand and complete the LOOM project: countertops with integrated sinks and shelves, shelves, and shower trays. Each element is designed to ensure stylistic and material consistency in a perfect balance between functionality and design. The entire project is developed with maximum coordination with the large Mega® slabs, creating a continuous dialogue between furnishings, wall coverings, and floors that enhances the expressive power of Italgraniti porcelain stoneware.

Neue Einrichtungselemente erweitern und vervollständigen das Projekt LOOM: Waschtische mit integrierten Waschbecken und Ablageflächen, Regale und Duschwannen – jedes Element ist so konzipiert, dass es stilistische und materielle Kohärenz in einer perfekten Balance zwischen Funktionalität und Design gewährleistet. Das gesamte Projekt steht im Zeichen einer maximalen Abstimmung mit den großen Mega®-Platten und schafft einen kontinuierlichen Dialog zwischen Einrichtungsgegenständen, Verkleidungen und Fußböden, der die Ausdruckskraft des Feinsteinzeugs von Italgraniti unterstreicht.

De nouveaux éléments d'ameublement viennent compléter et enrichir le projet LOOM : plans avec lavabos intégrés et d'appoint, étagères et receveurs de douche, chaque élément est conçu pour garantir une cohérence stylistique et matérielle dans un équilibre parfait entre fonctionnalité et design. L'ensemble du projet se développe sous le signe d'une coordination maximale avec les grandes dalles Mega®, créant un dialogue continu entre le mobilier, les revêtements et les sols qui met en valeur la force expressive du grès cérame Italgraniti.

### Art direction Andrea Parisio & Giuseppe Pezzano.

La direzione artistica degli architetti Andrea Parisio e Giuseppe Pezzano è parte integrante del percorso stilistico di Italgraniti e contribuisce, con continuità e visione, alla valorizzazione dell'identità dell'azienda. La sinergia con architetti e designer di fama internazionale arricchisce l'espressività dei prodotti e conferma l'impegno di Italgraniti nel proporre soluzioni che integrano qualità, responsabilità ambientale e visione progettuale.

The artistic direction of architects Andrea Parisio and Giuseppe Pezzano is an integral part of Italgraniti's stylistic approach and contributes, with continuity and vision, to enhancing the company's identity. The synergy with internationally renowned architects and designers enriches the expressiveness of the products and confirms Italgraniti's commitment to offering solutions that integrate quality, environmental responsibility, and design vision.



Die künstlerische Leitung der Architekten Andrea Parisio und Giuseppe Pezzano ist ein wesentlicher Bestandteil der stilistischen Entwicklung von Italgraniti und trägt mit Kontinuität und Weitblick zur Stärkung der Identität des Unternehmens bei. Die Zusammenarbeit mit international renommierten Architekten und Designern bereichert die Ausdruckskraft der Produkte und bestätigt das Engagement von Italgraniti, Lösungen anzubieten, die Qualität, Umweltbewusstsein und gestalterische Vision miteinander verbinden.

La direction artistique des architectes Andrea Parisio et Giuseppe Pezzano fait partie intégrante du parcours stylistique d'Italgraniti et contribue, avec continuité et vision, à la valorisation de l'identité de l'entreprise. La synergie avec des architectes et des designers de renommée internationale enrichit l'expressivité des produits et confirme l'engagement d'Italgraniti à proposer des solutions qui allient qualité, responsabilité environnementale et vision conceptuelle.





## Designed, industrialised and produced in Italy.

Italgraniti è riconosciuta a livello internazionale per le altissime prestazioni del suo gres porcellanato, sintesi di innovazione, design e qualità produttiva. Un risultato che affonda le proprie radici nel modello Made in Italy, da sempre al centro dell'identità industriale dell'azienda. Tutte le superfici ceramiche sono disegnate, sviluppate e realizzate in Italia, nel distretto ceramico, dove Italgraniti ha consolidato un sistema produttivo avanzato che unisce competenze tecniche, cultura del progetto e responsabilità sociale.

Italgraniti is internationally renowned for the high performance of its porcelain stoneware, which combines innovation, design, and production quality. This achievement has its roots in the Made in Italy model, which has always been at the heart of the company's industrial identity. All ceramic surfaces are designed, developed, and manufactured in Italy, in the ceramic district, where Italgraniti has consolidated an advanced production system that combines technical expertise, design culture, and social responsibility.



**MADE IN ITALY**

Italgraniti ist international für die hohe Leistungsfähigkeit seines Feinsteinzeugs bekannt, das Innovation, Design und Produktionsqualität vereint. Ein Ergebnis, das seine Wurzeln im Modell „Made in Italy“ hat, das seit jeher im Mittelpunkt der industriellen Identität des Unternehmens steht. Alle Keramikoberflächen werden in Italien entworfen, entwickelt und hergestellt, im Keramikbezirk, wo Italgraniti ein fortschrittliches Produktionssystem etabliert hat, das technisches Know-how, Designkultur und soziale Verantwortung vereint.

Italgraniti est reconnue au niveau international pour les performances exceptionnelles de son grès cérame, synthèse d'innovation, de design et de qualité de production. Un résultat qui trouve ses racines dans le modèle Made in Italy, depuis toujours au cœur de l'identité industrielle de l'entreprise. Toutes les surfaces céramiques sont conçues, développées et réalisées en Italie, dans le district céramique, où Italgraniti a consolidé un système de production avancé qui allie compétences techniques, culture du projet et responsabilité sociale.

**44 Marble Effect**

46 Calcis

62 Marble Touch

76 I Travertini

98 Marble

Charm Experience

Lux Experience

Marble Experience



Visone 120x280x0,6, Corda 120x120

# Calcis

Gres porcellanato - Rettificato / Porcelain Stoneware - Rectified  
Feinsteinzeug - Kalibriert / Gres Cerame - Rectifié

New Innovative  
Technology

RealUp®



Download  
Catalogue

Conforming to Standards

EN 14411 ISO 13006 APPENDICE G GRUPPO BIa UGL CON Ev ≤ 0,5%

\* EN 14411 ISO 13006 APPENDICE G GRUPPO BIa GL CON Ev ≤ 0,5%

Caratteristiche tecniche  
Technical features

BENDING STRENGTH	FROST RESISTANCE	CHEMICAL RESISTANCE	STAIN RESISTANCE			
ANSI A326.3 > 0,42	R10 / A+B	R11 / A+B+C	TRAFFICO MEDIO MEDIUM TRAFFIC	TRAFFICO INTENSO HEAVY TRAFFIC	V2 MODERATE	UNITÀ DI BRILLANTEZZA GLOSS UNIT
RealUp Antislip OPEN	RealUp	Antislip OPEN	Lappato / Polished (Crema)	RealUp Antislip	All Colours	Lappato > 80 Very Glossy Surface (Crema)

Formati  
Sizes

	6 mm	12 mm	9 mm						20 mm - OPEN
<b>SUPERFICIE SURFACE</b>	120x280x0,6 cm 47 <sup>1/4</sup> "x110 <sup>1/4</sup> "x1/4"	160x320x1,2 cm 62 <sup>7/8</sup> "x125 <sup>3/4</sup> "x1/2"	120x120 cm 47 <sup>1/4</sup> "x47 <sup>1/4</sup> "	80x80 cm 31 <sup>1/2</sup> "x31 <sup>1/2</sup> "	60x120 cm 23 <sup>1/2</sup> "x47 <sup>1/4</sup> "	60x60 cm 23 <sup>1/2</sup> "x23 <sup>1/2</sup> "	30x60 cm 11 <sup>7/8</sup> "x23 <sup>1/2</sup> "	Not rectified 30x60 cm 11 <sup>7/8</sup> "x23 <sup>1/2</sup> "	60x120 cm 23 <sup>1/2</sup> "x47 <sup>1/4</sup> "
RealUp	■		■	■	■	■	■		
*Lappato / Polished Anpoliert / Adouci	■		■		■				
Stripe					■				
RealUp Seta / Silk		■							
Antislip					■			■	■

Colori  
Colours



Avorio Crema Visone Corda

Superficie  
Surface finishes



RealUp \*Lappato Polished Available only in Crema Stripe Antislip



Calcis Avorio 120x280, Calcis Crema Antislip 60x120, Calcis Crema Listello Tratto 20x120



Avorio 120x280x0,6, Crema 120x120



Corda Stripe 60x120, Corda 60x120



Corda 60x120, Visone 60x120 20mm

### Avorio



### Avorio Stripe

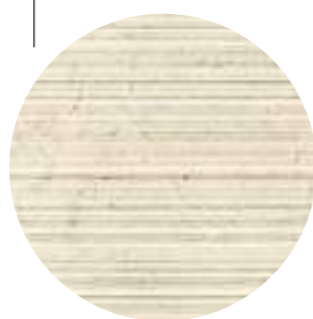

Il Decoro Stripe non garantisce continuità di struttura tra un pezzo e l'altro. / The Stripe Decor does not guarantee continuity of the structure between pieces. / Bei dem Dekor Stripe ist die Kontinuität der Linienstruktur zwischen einem Stück und dem nächsten nicht gewährleistet. / Le décor Stripe ne garanti aucune continuité entre une pièce et l'autre.

### Crema



### Crema Stripe

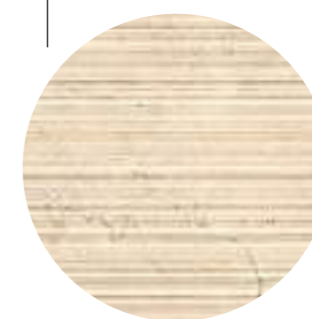

Il Decoro Stripe non garantisce continuità di struttura tra un pezzo e l'altro. / The Stripe Decor does not guarantee continuity of the structure between pieces. / Bei dem Dekor Stripe ist die Kontinuität der Linienstruktur zwischen einem Stück und dem nächsten nicht gewährleistet. / Le décor Stripe ne garanti aucune continuité entre une pièce et l'autre.

	6 mm	12 mm	9 mm - RealUp					Not rectified
	120x280x0,6 cm 47 <sup>1/4</sup> "x110 <sup>1/4</sup> "x1/4"	160x320x1,2 cm 62 <sup>7/8</sup> "x125 <sup>3/4</sup> "x1/2"	120x120 cm 47 <sup>1/4</sup> "x47 <sup>1/4</sup> "	80x80 cm 31 <sup>1/2</sup> "x31 <sup>1/2</sup> "	60x120 cm 23 <sup>1/2</sup> "x47 <sup>1/4</sup> "	60x60 cm 23 <sup>1/2</sup> "x23 <sup>1/2</sup> "	30x60 cm 11 <sup>7/8</sup> "x23 <sup>1/2</sup> "	30x60 cm 11 <sup>7/8</sup> "x23 <sup>1/2</sup> "
RealUp	UGL	CL01XPA ■ 110	CL0112 ■ 078	CL0188 ■ 062	CL01BA ■ 068	CL0168 ■ 052	CL0163 ■ 052	
Antislip	UGL			CL01BAA ■ 068				CL0160A ■ 037
RealUp Seta / Silk	UGL	LM24XA12 ■ 242						
Stripe	UGL			CL01BAS ■ 080				

	6 mm	12 mm	9 mm - RealUp					Not rectified
	120x280x0,6 cm 47 <sup>1/4</sup> "x110 <sup>1/4</sup> "x1/4"	160x320x1,2 cm 62 <sup>7/8</sup> "x125 <sup>3/4</sup> "x1/2"	120x120 cm 47 <sup>1/4</sup> "x47 <sup>1/4</sup> "	80x80 cm 31 <sup>1/2</sup> "x31 <sup>1/2</sup> "	60x120 cm 23 <sup>1/2</sup> "x47 <sup>1/4</sup> "	60x60 cm 23 <sup>1/2</sup> "x23 <sup>1/2</sup> "	30x60 cm 11 <sup>7/8</sup> "x23 <sup>1/2</sup> "	30x60 cm 11 <sup>7/8</sup> "x23 <sup>1/2</sup> "
RealUp	UGL	CL02XPA ■ 110	CL0212 ■ 078	CL0288 ■ 062	CL02BA ■ 068	CL0268 ■ 052	CL0263 ■ 052	
Antislip	UGL				CL02BAA ■ 068			CL0260A ■ 037
RealUp Seta / Silk	UGL	LM23XA12 ■ 242						
Lappato / Polished	GL	CL02XPL ■ 140	CL0212L ■ 115		CL02BAL ■ 095			
Stripe	UGL				CL02BAS ■ 080			

### Visone



### Visone Stripe

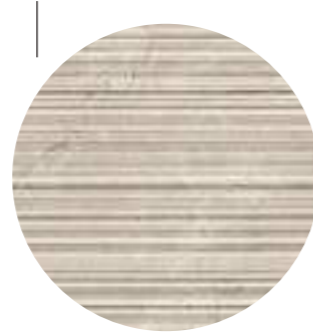

Il Decoro Stripe non garantisce continuità di struttura tra un pezzo e l'altro. / The Stripe Decor does not guarantee continuity of the structure between pieces. / Bei dem Dekor Stripe ist die Kontinuität der Linienstruktur zwischen einem Stück und dem nächsten nicht gewährleistet. / Le décor Stripe ne garanti aucune continuité entre une pièce et l'autre.

### Corda



### Corda Stripe

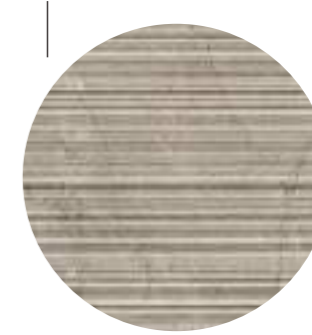

Il Decoro Stripe non garantisce continuità di struttura tra un pezzo e l'altro. / The Stripe Decor does not guarantee continuity of the structure between pieces. / Bei dem Dekor Stripe ist die Kontinuität der Linienstruktur zwischen einem Stück und dem nächsten nicht gewährleistet. / Le décor Stripe ne garanti aucune continuité entre une pièce et l'autre.

■ 9 mm - RealUp

■ 20 mm - OPEN

	120x120 cm 47 <sup>1/8</sup> "x47 <sup>1/8</sup> "	80x80 cm 31 <sup>1/2</sup> "x31 <sup>1/2</sup> "	60x120 cm 23 <sup>1/2</sup> "x47 <sup>1/8</sup> "	60x60 cm 23 <sup>1/2</sup> "x23 <sup>1/2</sup> "	30x60 cm 11 <sup>7/8</sup> "x23 <sup>1/2</sup> "	Not rectified 30x60 cm 11 <sup>7/8</sup> "x23 <sup>1/2</sup> "	60x120 cm 23 <sup>1/2</sup> "x47 <sup>1/8</sup> "
RealUp	UGL	CL0312 ■ 078	CL0388 ■ 062	CL03BA ■ 068	CL0368 ■ 052	CL0363 ■ 052	
Antislip	UGL			CL03BAA ■ 068		CL0360A ■ 037	CL03BA2 ■ 095
Stripe	UGL		CL03BAS ■ 080				

■ 9 mm - RealUp

■ 20 mm - OPEN

	120x120 cm 47 <sup>1/8</sup> "x47 <sup>1/8</sup> "	80x80 cm 31 <sup>1/2</sup> "x31 <sup>1/2</sup> "	60x120 cm 23 <sup>1/2</sup> "x47 <sup>1/8</sup> "	60x60 cm 23 <sup>1/2</sup> "x23 <sup>1/2</sup> "	30x60 cm 11 <sup>7/8</sup> "x23 <sup>1/2</sup> "	Not rectified 30x60 cm 11 <sup>7/8</sup> "x23 <sup>1/2</sup> "	60x120 cm 23 <sup>1/2</sup> "x47 <sup>1/8</sup> "
RealUp	UGL	CL0412 ■ 078	CL0488 ■ 062	CL04BA ■ 068	CL0468 ■ 052	CL0463 ■ 052	
Antislip	UGL			CL04BAA ■ 068		CL0460A ■ 037	CL04BA2 ■ 095
Stripe	UGL		CL04BAS ■ 080				

## Listello Tratto

20x120



Avorio  
6 mm / 9 mm



Crema  
6 mm / 9 mm



Visone  
9 mm



Corda  
9 mm

## Muretto

30x30



Avorio  
6 mm / 9 mm

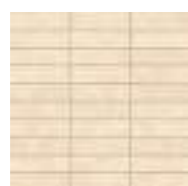

Crema  
6 mm / 9 mm



Visone  
9 mm



Corda  
9 mm

## Mosaico

30x30



Avorio  
9 mm

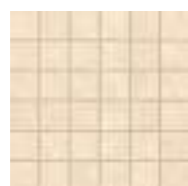

Crema  
9 mm



Visone  
9 mm



Corda  
9 mm

		6 mm			9 mm		
		Listello Tratto 20x120 cm 8"x47 1/4"	Muretto 30x30 cm 1 1/8"x1 7/8"	Listello Tratto 20x120 cm 8"x47 1/4"	Muretto 30x30 cm 1 1/8"x1 7/8"	Mosaico 30x30 cm 1 1/8"x1 7/8"	
		(Pcs Box 6)	(Pcs Box 6)	(Pcs Box 6)	(Pcs Box 6)	(Pcs Box 12)	
Lappato / Polished GL	CREMA	CL02LTL	CL02MBL	CL02LTL9	CL02MBL9	CL023ML	193
	AVORIO	CL01LT	CL01MB	CL01LT9	CL01MB9	CL013MA	137
	CREMA	CL02LT	CL02MB	CL02LT9	CL02MB9	CL023MA	137
RealUp	UGL	CL03LT9	CL03MB9	CL03LT9	CL03MB9	CL033MA	137
	VISIONE	CL04LT9	CL04MB9	CL04LT9	CL04MB9	CL043MA	137
	CORDA						



Su rete / Mesh mounted



Tessera  
2,5x120 1"x47 1/4"



Tessera  
2,8x9,8 1 1/8"x3 7/8"



Tessera  
5x5 2"x2"

Listello Tratto

Muretto

Mosaico A

## Pezzi speciali / Special pieces

9 mm



Battiscopa

7x60 cm  
2 3/4"x23 1/2"

(Pcs Box 10)



Battiscopa

7x120 cm  
2 3/4"x47 1/4"

(Pcs Box 8)



Gradone  
con Toro

120x33x4 cm  
47 1/4"x13 1/4"

(Pcs Box 2)



Elemento "L"  
Incollato

4,5x16,5x60 cm  
1 3/4"x6 1/2"x23 1/2"

(Pcs Box 4)

AVORIO	RealUp	CL0176	009	CL01B77	018	CL01GT2	223	CL01951	059
	RealUp	CL0276	009	CL02B77	018	CL02GT2	223	CL02951	059
CREMA	Lappato / Polished GL	CL02B7L	021	CL02GT3	261				
VISIONE	RealUp	CL0376	009	CL03B77	018	CL03GT2	223	CL03951	059
CORDA	RealUp	CL0476	009	CL04B77	018	CL04GT2	223	CL04951	059



Download Catalogue

## 20 mm Open - Pezzi speciali / Special pieces

Per approfondimenti sui pezzi speciali e tutti gli accessori per esterno 20mm scarica la scheda tecnica oppure consultare il nostro sito e il catalogo Open.

For further information on special pieces and all 20mm outdoor accessories download the technical data sheet or consult our website and the Open catalog.

Für weitere Informationen zu Sonderteilen und dem gesamten 20mm Outdoor-Zubehör laden Sie das technische Datenblatt herunter oder besuchen Sie unsere Website und den Open-Katalog.

Pour approfondissements sur les pièces de finition et accessoires pour extérieurs de 20mm: merci de télécharger la fiche technique ou bien consulter notre site web et le catalogue OPEN.

## Imballi / Packing

				PCS / BOX	M <sup>2</sup> / BOX	KG / BOX	BOX / PALLET	M <sup>2</sup> / PALLET	KG / PALLET
120x120 cm - 47 1/4"x47 1/4"	Thick 9 mm	RealUp		PZ / PCS 2	M <sup>2</sup> 2,88	KG 59,44	PZ / PCS 18	M <sup>2</sup> 51,84	KG 1.090,08
60x120 cm - 23 1/2"x47 1/4"	Thick 9 mm	RealUp / Lappato / Antislip		PZ / PCS 2	M <sup>2</sup> 1,44	KG 29,59	PZ / PCS 36	M <sup>2</sup> 51,84	KG 1.085,52
60x60 cm - 23 1/2"x23 1/2"	Thick 9 mm	RealUp		PZ / PCS 4	M <sup>2</sup> 1,44	KG 27,94	PZ / PCS 30	M <sup>2</sup> 43,20	KG 858,35
OPEN 60x120 cm - 23 1/2"x47 1/4"	Thick 20 mm	Antislip		PZ / PCS 1	M <sup>2</sup> 0,72	KG 32,65	PZ / PCS 36	M <sup>2</sup> 25,92	KG 1.195,68
80x80 cm - 31 1/2"x31 1/2"	Thick 9 mm	RealUp		PZ / PCS 2	M <sup>2</sup> 1,28	KG 28,00	PZ / PCS 42	M <sup>2</sup> 53,76	KG 1.196,33
30x60 cm - 11 7/8"x23 1/2"	Thick 9 mm	RealUp / Antislip		PZ / PCS 8	M <sup>2</sup> 1,44	KG 28,24	PZ / PCS 32	M <sup>2</sup> 46,08	KG 923,71
Decoro Stripe 60x120 cm - 23 1/2"x47 1/4"	Thick 9 mm	RealUp		PZ / PCS 2	M <sup>2</sup> 1,44	KG 28,29	PZ / PCS 36	M <sup>2</sup> 51,84	KG 1.038,44
Listello Tratto 20x120 cm - 8"x47 1/4"	Thick 6 mm	RealUp / Lappato		PZ / PCS 6	M <sup>2</sup> 1,44	KG 19,02	PZ / PCS 30	M <sup>2</sup> 43,20	KG 590,60
Listello Tratto 20x120 cm - 8"x47 1/4"	Thick 9 mm	RealUp / Lappato		PZ / PCS 6	M <sup>2</sup> 1,44	KG 26,98	PZ / PCS 28	M <sup>2</sup> 40,32	KG 775,49
Muretto 30x30 cm - 11 7/8"x11 7/8"	Thick 6 mm	RealUp / Lappato		PZ / PCS 6	M <sup>2</sup> 0,54	KG 7,20	PZ / PCS 60	M <sup>2</sup> 32,40	KG 452,00
Muretto 30x30 cm - 11 7/8"x11 7/8"	Thick 9 mm	RealUp / Lappato		PZ / PCS 6	M <sup>2</sup> 0,54	KG 10,45	PZ / PCS 60	M <sup>2</sup> 32,40	KG 647,48
Mosaico 30x30 cm - 11 7/8"x11 7/8"	Thick 9 mm	RealUp / Lappato		PZ / PCS 12	M <sup>2</sup> 1,08	KG 20,62	PZ / PCS 30	M <sup>2</sup> 32,40	KG 635,60

## Imballi Mega / Mega Packing

	DESCRIZIONE IMBALLO PACKAGING DESCRIPTION	MQ / KG LASTRA / SLAB		IMBALLO PIENO FULL PACKAGING		IMBALLO VUOTO EMPTY PACKAGING	
		MQ	KG	KG	KG	KG	KG
120x280x0,6 cm 47 1/4"x110 1/4"x1/4"	CASSA / CRATE L 145 x P 292 x H 35	MQ 3,36	KG 48,60	KG 1062,00	KG 100,00		
				PZ 20			
120x280x0,6 cm 47 1/4"x110 1/4"x1/4"	CAVALLETTO / A-FRAME L 75 x P 285 x H 153	MQ 3,36	KG 48,60	KG 2318,40	KG 180,00		
				PZ 44			
		MQ 3,36	KG 48,60	KG 527,40	KG 90,00		
				PZ 1 / 9			

## Stucchi consigliati / Recommended grouts

Colori Colors	Avorio	Crema	Visone	Corda
Kerakoll	KK76	KK89	KK109	KK110
Mapei	60% 110 + 40% 131	137	80% 110 + 20% 137	80% 110 + 20% 133

Le tipologie di stucchi riportate nella tabella sono semplici suggerimenti. Prima della posa si raccomanda di eseguire un test di stuccatura per verificarne la compatibilità con la superficie ceramica e le condizioni di utilizzo. / The types of grout listed in the table are simply suggestions. Before installation, it is recommended to perform a grouting test to verify compatibility with the ceramic surface and conditions of use. / Die in der Tabelle aufgeführten Fugenmörteltypen sind lediglich Empfehlungen. Vor dem Verlegen wird empfohlen, einen Fugentest durchzuführen, um die Verträglichkeit mit der Keramikoberfläche und den Einsatzbedingungen zu überprüfen. / Les types de mastics indiqués dans le tableau sont de simples suggestions. Avant la pose, il est recommandé d'effectuer un test de masticage afin de vérifier la compatibilité avec la surface céramique et les conditions d'utilisation.

Pag. 415: approfondimenti calibri specifici / Pag. 415: further information on specific working sizes / S. 415: Vertiefungen über spezifische Werkmaße / Pag. 415: approfondissements dimensions de fabrication spécifiques



# Marble Touch

Gres porcellanato - Rettificato / Porcelain Stoneware - Rectified  
 Feinsteinzeug - Kalibriert / Gres Cerame - Rectifié

New Innovative  
 Technology



Download  
 Catalogue

RealUp®

Conforming to Standards

EN 14411 ISO 13006 APPENDICE G GRUPPO BIa UGL CON Ev ≤ 0,5%

\* EN 14411 ISO 13006 APPENDICE G GRUPPO BIa GL CON Ev ≤ 0,5%

Caratteristiche tecniche  
 Technical features

BENDING STRENGTH	FROST RESISTANCE	CHEMICAL RESISTANCE	STAIN RESISTANCE
ANSI A326.3 > 0,42	TRAFFICO MEDIO MEDIUM TRAFFIC	TRAFFICO INTENSO HEAVY TRAFFIC	V3 HIGH
RealUp	Lappato / Polished	RealUp	All Colours
			UNITÀ DI BRILLANTEZZA GLOSS UNIT
			Lappato > 80 Very Glossy Surface All Colours

Formati  
 Sizes

<b>SUPERFICIE SURFACE</b>	120x280x0,6 cm 47 <sup>1/4</sup> "x110 <sup>1/4</sup> "x1/4"	160x320x1,2 cm 62 <sup>7/8</sup> "x125 <sup>3/8</sup> "x1/2"	120x120 cm 47 <sup>1/4</sup> "x47 <sup>1/4</sup> "	60x120 cm 23 <sup>1/2</sup> "x47 <sup>1/4</sup> "	60x60 cm 23 <sup>1/2</sup> "x23 <sup>1/2</sup> "
RealUp					
*Lappato / Polished Anpoliert / Adouci					
RealUp Seta / Silk					
Stripe					

Colori  
 Colours



Calacatta Extra Calacatta Top

Superficie  
 Surface finishes

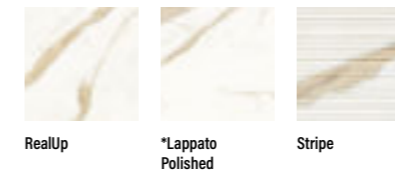

RealUp \*Lappato Polished Stripe

Calacatta Top Stripe 120x60



Calacatta Top Stripe 120x60, Essence Select Miele 20x120



Calacatta Top 120x280x0,6, Essence Select Miele 20x120, Nuances Avorio 120x280



Calacatta Top 120x280x0,6, Listelli/Tozzetti 10x120/10x10, Nuances Avorio 120x280x0,6, Dorset Cenere Cross Cut 120x120

Calacatta Extra



Calacatta Extra Lappato



Calacatta Top



Calacatta Top Lappato



	6 mm	12 mm	9 mm - RealUp		
	120x280x0,6 cm 47 <sup>1/4</sup> "x110 <sup>1/4</sup> "x1/4"	160x320x1,2 cm 62 <sup>7/8</sup> "x125 <sup>3/4</sup> "x1/2"	120x120 cm 47 <sup>1/4</sup> "x47 <sup>1/4</sup> "	60x120 cm 23 <sup>1/2</sup> "x47 <sup>1/4</sup> "	60x60 cm 23 <sup>1/2</sup> "x23 <sup>1/2</sup> "
RealUp	UGL MT01XPA ■ 110		MT0112 ■ 082	MT01BA ■ 072	MT0168 ■ 056
Real Up Seta / Silk	UGL	A LM21AXA12 ■ 242 B LM21BXA12 ■ 242			
Real Up Vena Continua / RealUp Continuous Veining	UGL	MTVIXPA ■ 135			
Lappato / Polished	GL	MT01XPL ■ 140	MT0112L ■ 115	MT01BAL ■ 095	
Lappato Vena Continua / Polished Continuous Veining	GL	MTVIXPL ■ 170			
Stripe	UGL			MT01BAS ■ 080	

Vena Continua 4 lastre 120x280x0,6  
Continuous veining 4 slabs 120x280x0,6

Lappato



	6 mm	12 mm	9 mm - RealUp		
	120x280x0,6 cm 47 <sup>1/4</sup> "x110 <sup>1/4</sup> "x1/4"	160x320x1,2 cm 62 <sup>7/8</sup> "x125 <sup>3/4</sup> "x1/2"	120x120 cm 47 <sup>1/4</sup> "x47 <sup>1/4</sup> "	60x120 cm 23 <sup>1/2</sup> "x47 <sup>1/4</sup> "	60x60 cm 23 <sup>1/2</sup> "x23 <sup>1/2</sup> "
RealUp	UGL MT02XPA ■ 110		MT0212 ■ 082	MT02BA ■ 072	MT0268 ■ 056
Real Up Seta / Silk	UGL	A LM22AXA12 ■ 242 B LM22BXA12 ■ 242			
Real Up Vena Continua / RealUp Continuous Veining	UGL	MTV2XPA ■ 135			
Lappato / Polished	GL	MT02XPL ■ 140	MT0212L ■ 115	MT02BAL ■ 095	
Lappato Vena Continua / Polished Continuous Veining	GL	MTV2XPL ■ 170			
Stripe	UGL			MT02BAS ■ 080	

Vena Continua 4 lastre 120x280x0,6  
Continuous veining 4 slabs 120x280x0,6

RealUp

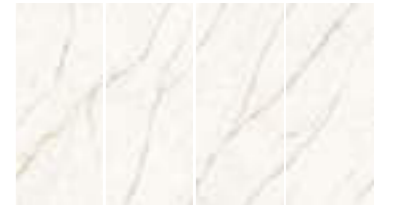

### Listello / Tozzetto



Schema di posa / Installation system

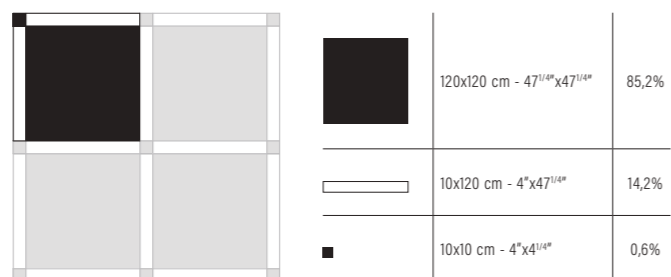

9 mm

Listello 10x120 cm 4"x47 1/4" (Pcs Box 6)  
Tozzetto 10x10 cm 4"x4" (Pcs Box 6)

RealUp	GL	CALACATTA EXTRA	MT01L10	017	MT01T10	003
		CALACATTA TOP	MT02L10	017	MT02T10	003

### Listello Tratto

20x120



### Muretto

30x30

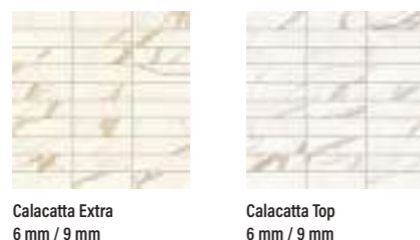

### Mosaico

30x30

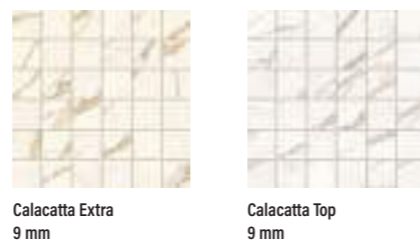

6 mm

9 mm

Listello Tratto 20x120 cm 8"x47 1/4" (Pcs Box 6)  
Muretto 30x30 cm 11 7/8"x11 7/8" (Pcs Box 6)  
Listello Tratto 30x30 cm 8"x47 1/4" (Pcs Box 6)  
Muretto 30x30 cm 11 7/8"x11 7/8" (Pcs Box 6)  
Mosaico 30x30 cm 11 7/8"x11 7/8" (Pcs Box 12)

RealUp	UGL	CALACATTA EXTRA	MT01LT	098	MT01MB	043	MT01LT9	064	MT01MB9	027	MT013MA	137
		CALACATTA TOP	MT02LT	098	MT02MB	043	MT02LT9	064	MT02MB9	027	MT023MA	137
Lappato	GL	CALACATTA EXTRA	MT01LTL	112	MT01MBL	047	MT01LTL9	080	MT01MBL9	034	MT013ML	193
Polished		CALACATTA TOP	MT02LTL	112	MT02MBL	047	MT02LTL9	080	MT02MBL9	034	MT023ML	193

Su rete / Mesh mounted	Listello Tratto	Muretto	Mosaico A
------------------------	-----------------	---------	-----------

### Calacatta Extra Stripe



### Calacatta Top Stripe



9 mm

60x120 cm 23 1/2"x47 1/4"

StrideUp	UGL	CALACATTA EXTRA STRIPE	MT01BAS	080
		CALACATTA TOP STRIPE	MT02BAS	080

Il Decoro Stripe non garantisce continuità di struttura tra un pezzo e l'altro. / The Stripe Decor does not guarantee continuity of the structure between pieces. / Bei dem Dekor Stripe ist die Kontinuität der Linienstruktur zwischen einem Stück und dem nächsten nicht gewährleistet. / Le décor Stripe ne garanti aucune continuité entre une pièce et l'autre.



Marble Touch Calacatta Extra Lappato 120x280x0,6, Stripe 120x60, Nuances Avorio 120x280x0,6

Pezzi speciali / Special pieces

■ 9 mm



CALACATTA EXTRA	RealUp	MT0176 ■ 009	MT01BT7 ■ 018	MT01GT2 ■ 223
	Lappato / Polished GL		MT01BT7L ■ 021	MT01GT3 ■ 261
CALACATTA TOP	RealUp	MT0276 ■ 009	MT02BT7 ■ 018	MT02GT2 ■ 223
	Lappato / Polished GL		MT02BT7L ■ 021	MT02GT3 ■ 261

Imballi / Packing

				PCS / BOX	M <sup>2</sup> / BOX	KG / BOX	BOX / PALLET	M <sup>2</sup> / PALLET	KG / PALLET
	120x120 cm - 47 <sup>1/4</sup> "x47 <sup>1/4</sup> "	Thick 9 mm	RealUp	PZ / PCS 2	M <sup>2</sup> 2,88	KG 58,70	PZ / PCS 18	M <sup>2</sup> 51,87	KG 1.076,76
	120x120 cm - 47 <sup>1/4</sup> "x47 <sup>1/4</sup> "	Thick 9 mm	Lappato	PZ / PCS 2	M <sup>2</sup> 2,88	KG 60,93	PZ / PCS 18	M <sup>2</sup> 51,84	KG 1.116,83
	60x120 cm - 23 <sup>1/2</sup> "x47 <sup>1/4</sup> "	Thick 9 mm	RealUp	PZ / PCS 2	M <sup>2</sup> 1,44	KG 29,22	PZ / PCS 36	M <sup>2</sup> 51,84	KG 1.072,02
	60x120 cm - 23 <sup>1/2</sup> "x47 <sup>1/4</sup> "	Thick 9 mm	Lappato	PZ / PCS 2	M <sup>2</sup> 1,44	KG 29,81	PZ / PCS 36	M <sup>2</sup> 51,84	KG 1.093,41
	60x60 cm - 23 <sup>1/2</sup> "x23 <sup>1/2</sup> "	Thick 9 mm	RealUp	PZ / PCS 4	M <sup>2</sup> 1,44	KG 27,76	PZ / PCS 30	M <sup>2</sup> 43,20	KG 852,95
	Decoro Stripe 60x120 cm - 23 <sup>1/2</sup> "x47 <sup>1/4</sup> "	Thick 9 mm	RealUp	PZ / PCS 2	M <sup>2</sup> 1,44	KG 29,81	PZ / PCS 36	M <sup>2</sup> 51,84	KG 1.093,41
	Listello Tratto 20x120 cm - 8"x47 <sup>1/4</sup> "	Thick 6 mm	RealUp / Lappato	PZ / PCS 6	M <sup>2</sup> 1,44	KG 19,00	PZ / PCS 30	M <sup>2</sup> 40,32	KG 590,60
	Listello Tratto 20x120 cm - 8"x47 <sup>1/4</sup> "	Thick 9 mm	RealUp / Lappato	PZ / PCS 6	M <sup>2</sup> 1,44	KG 26,83	PZ / PCS 28	M <sup>2</sup> 40,32	KG 771,46
	Muretto 30x30 cm - 11 <sup>7/8</sup> "x11 <sup>7/8</sup> "	Thick 6 mm	RealUp / Lappato	PZ / PCS 6	M <sup>2</sup> 0,54	KG 7,20	PZ / PCS 60	M <sup>2</sup> 32,40	KG 452,00
	Muretto 30x30 cm - 11 <sup>7/8</sup> "x11 <sup>7/8</sup> "	Thick 9 mm	RealUp / Lappato	PZ / PCS 6	M <sup>2</sup> 0,54	KG 10,45	PZ / PCS 60	M <sup>2</sup> 32,40	KG 647,48
	Mosaico 30x30 cm - 11 <sup>7/8</sup> "x11 <sup>7/8</sup> "	Thick 9 mm	RealUp / Lappato	PZ / PCS 12	M <sup>2</sup> 1,08	KG 20,30	PZ / PCS 30	M <sup>2</sup> 32,40	KG 629,00
	Listello 10x120 cm - 4"x47 <sup>1/4</sup> "	Thick 9 mm	RealUp	PZ / PCS 6	M <sup>2</sup> 0,72	KG 26,84	PZ / PCS 40	M <sup>2</sup> 28,80	KG 1.093,52
	Tozzetto 10x10 cm - 4"x4"	Thick 9 mm	RealUp	PZ / PCS 6	M <sup>2</sup> 0,06	KG 0,75	PZ / PCS 572	M <sup>2</sup> 34,32	KG 449,00

Imballi Mega / Mega Packing

		DESCRIZIONE IMBALLO PACKAGING DESCRIPTION	MQ / KG LASTRA / SLAB	IMBALLO PIENO FULL PACKAGING	IMBALLO VUOTO EMPTY PACKAGING
	120x280x0,6 cm 47 <sup>1/4</sup> "x110 <sup>1/4</sup> "x1/4"	CASSA / CRATE L 145 x P 292 x H 35	MQ 3,36	MQ 67,20	
			KG 48,60	KG 1062,00	KG 100,00
	120x280x0,6 cm 47 <sup>1/4</sup> "x110 <sup>1/4</sup> "x1/4"	CAVALLETTO / A-FRAME L 75 x P 285 x H 153	MQ 3,36	MQ 147,84	
			KG 48,60	KG 2318,40	KG 180,00
	120x280x0,6 cm 47 <sup>1/4</sup> "x110 <sup>1/4</sup> "x1/4"	CASSA LIGHT / LIGHT CRATE L 145 x P 292 x H 27	MQ 3,36	MQ 30,24	
			KG 48,60	KG 527,40	KG 90,00
				PZ 1 / 9	

Stucchi consigliati / Recommended grouts

Colori Colors	Calacatta Extra	Calacatta Top
Kerakoll	KK76	KK2
Mapei	103	103

Le tipologie di stucchi riportate nella tabella sono semplici suggerimenti. Prima della posa si raccomanda di eseguire un test di stuccatura per verificarne la compatibilità con la superficie ceramica e le condizioni di utilizzo. / The types of grout listed in the table are simple suggestions. Before installation, it is recommended to perform a grouting test to verify compatibility with the ceramic surface and conditions of use. / Die in der Tabelle aufgeführten Fugenmörteltypen sind lediglich Empfehlungen. Vor dem Verlegen wird empfohlen, einen Fugentest durchzuführen, um die Verträglichkeit mit der Keramikoberfläche und den Einsatzbedingungen zu überprüfen. / Les types de mastics indiqués dans le tableau sont de simples suggestions. Avant la pose, il est recommandé d'effectuer un test de masticage afin de vérifier la compatibilité avec la surface céramique et les conditions d'utilisation.

Pag. 415: approfondimenti calibri specifici / Pag. 415: further information on specific working sizes / S. 415: Vertiefungen über spezifische Werkmaße / Pag. 415 : approfondissements dimensions de fabrication spécifiques



Calacatta Extra Stripe 60x120



archiproducts  
AWARDS  
WINNER

# I Travertini

Gres porcellanato - Rettificato / Porcelain Stoneware - Rectified  
Feinsteinzeug - Kalibriert / Gres Cerame - Rectifié

New Innovative  
Technology

RealUp®  
StrideUp®



Download  
Catalogue

Conforming to Standards  
EN 14411 ISO 13006 APPENDICE G GRUPPO BIa UGL CON Ev ≤ 0,5%

Caratteristiche tecniche  
Technical features

BENDING STRENGTH	FROST RESISTANCE	CHEMICAL RESISTANCE	STAIN RESISTANCE		
ANSI A326.3 > 0,42	R10 / A + B	R11 / A+B+C	TRAFFICO INTENSO HEAVY TRAFFIC	V2 MODERATE	V3 HIGH
RealUp + StrideUp Naturale / Matte Antislip OPEN	RealUp + StrideUp	Antislip OPEN	RealUp + StrideUp Naturale / Matte Antislip OPEN	Bianco Vein / Cross Cut Beige Vein / Cross Cut Grigio Vein / Cross Cut	Rosso Vein Cut

Formati  
Sizes

	6 mm	12 mm	9 mm - RealUp + StrideUp				20 mm - OPEN	
<b>SUPERFICIE SURFACE</b>	120x280x0,6 cm 47 <sup>1/4</sup> "x110 <sup>1/4</sup> "x1/4"	160x320x1,2 cm 62 <sup>7/8</sup> "x125 <sup>3/4</sup> "x1/2"	80x160 cm 31 <sup>1/2</sup> "x63"	120x120 cm 47 <sup>1/8</sup> "x47 <sup>1/8</sup> "	60x120 cm 23 <sup>1/2</sup> "x47 <sup>1/8</sup> "	60x60 cm 23 <sup>1/2</sup> "x23 <sup>1/2</sup> "	30x60 cm 11 <sup>7/8</sup> "x23 <sup>1/2</sup> "	60x120 cm 23 <sup>1/2</sup> "x47 <sup>1/8</sup> "
Naturale / Matte Natur / Naturel	■							
RealUp	■	■						
RealUp + StrideUp			■	■	■	■	■	
Ribbed					■			
Antislip				■ <small>new</small>	■			■

Colori  
Colours

Bianco Vein Cut	Bianco Cross Cut	Beige Vein Cut	Beige Cross Cut	Grigio Vein Cut	Grigio Cross Cut	Rosso Vein Cut

Superficie  
Surface finishes

Naturale Matte	RealUp + StrideUp	Ribbed	Antislip

Grigio Cross Cut 120x120, Decoro Radio 3D Grigio 60x120



Grigio Cross Cut 120x120, Decoro Radio 3D Grigio 60x120, I Cementi White 120x280x0,6



Bianco Vein Cut 120x280x0,6, Ribbed Bianco Vein Cut 60x120, I Cementi White 120x280x0,6, Dark 120x120



I Travertini Rosso Vein Cut 80x160, Beige Listello Tratto 20x120, I Cementi Taupe 120x280x0,6



Decoro Radio 3D Grigio 60x120, I Cementi White 120x280x0,6, Bianco Cross Cut 120x120



### Bianco Vein Cut



### Bianco Cross Cut



### Bianco Vein Cut Ribbed



Il Decoro Ribbed non garantisce continuità di struttura tra un pezzo e l'altro. / The Ribbed Decor does not guarantee continuity of the structure between pieces. / Bei dem Dekor Ribbed ist die Kontinuität der Linienstruktur zwischen einem Stück und dem nächsten nicht gewährleistet. / Le décor Ribbed ne garanti aucune continuité entre une pièce et l'autre.

	6 mm	12 mm	9 mm - RealUp + StrideUp					20 mm - OPEN
	120x280x0,6 cm 47 <sup>11/16</sup> x110 <sup>11/16</sup> x1/4"	160x320x1,2 cm 62 <sup>7/8</sup> x125 <sup>3/4</sup> x1/2"	80x160 cm 31 <sup>1/2</sup> x63"	120x120 cm 47 <sup>11/16</sup> x47 <sup>11/16</sup> "	60x120 cm 23 <sup>1/2</sup> x47 <sup>11/16</sup> "	60x60 cm 23 <sup>1/2</sup> x23 <sup>1/2</sup> "	30x60 cm 11 <sup>7/8</sup> x23 <sup>1/2</sup> "	60x120 cm 23 <sup>1/2</sup> x47 <sup>11/16</sup> "
Naturale / Matte UGL	BIANCO VEIN CUT							
RealUp UGL	TR01XPA ■ 110	LM18XA12 ■ 242						
RealUp + StrideUp UGL	BIANCO VEIN CUT		TR01GA ■ 078		TR01BA ■ 068		TR0163 ■ 052	
Ribbed UGL	BIANCO CROSS CUT			TR0212 ■ 078	TR02BA ■ 068	TR0268 ■ 052	TR0263 ■ 052	
Antislip UGL	BIANCO VEIN CUT				TR01BAR ■ 080			TR01BA2 ■ 095
	BIANCO CROSS CUT			TR01BAA ■ 068				TR02BA2 ■ 095
			TR0212A ■ 078	TR02BAA ■ 068				



### Beige Vein Cut



### Beige Cross Cut



### Beige Vein Cut Ribbed



Il Decoro Ribbed non garantisce continuità di struttura tra un pezzo e l'altro. / The Ribbed Decor does not guarantee continuity of the structure between pieces. / Bei dem Dekor Ribbed ist die Kontinuität der Linienstruktur zwischen einem Stück und dem nächsten nicht gewährleistet. / Le décor Ribbed ne garanti aucune continuité entre une pièce et l'autre.

	6 mm	12 mm	9 mm - RealUp + StrideUp					20 mm - OPEN
	120x280x0,6 cm 47 <sup>11/16</sup> x110 <sup>11/16</sup> x1/4"	160x320x1,2 cm 62 <sup>7/8</sup> x125 <sup>3/4</sup> x1/2"	80x160 cm 31 <sup>1/2</sup> x63"	120x120 cm 47 <sup>11/16</sup> x47 <sup>11/16</sup> "	60x120 cm 23 <sup>1/2</sup> x47 <sup>11/16</sup> "	60x60 cm 23 <sup>1/2</sup> x23 <sup>1/2</sup> "	30x60 cm 11 <sup>7/8</sup> x23 <sup>1/2</sup> "	60x120 cm 23 <sup>1/2</sup> x47 <sup>11/16</sup> "
Naturale / Matte UGL	BEIGE VEIN CUT							
RealUp UGL	TR03XPA ■ 110	LM19XA12 ■ 242						
RealUp + StrideUp UGL	BEIGE VEIN CUT		TR03GA ■ 078		TR03BA ■ 068		TR0363 ■ 052	
Ribbed UGL	BEIGE CROSS CUT			TR0412 ■ 078	TR04BA ■ 068	TR0468 ■ 052	TR0463 ■ 052	
Antislip UGL	BEIGE VEIN CUT				TR03BAR ■ 080			TR03BA2 ■ 095
	BEIGE CROSS CUT			TR03BAA ■ 068				TR04BA2 ■ 095
			TR0412A ■ 078	TR04BAA ■ 068				

Grigio Vein Cut



Grigio Cross Cut



Grigio Vein Cut Ribbed

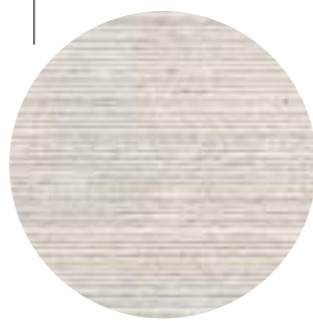

Il Decoro Ribbed non garantisce continuità di struttura tra un pezzo e l'altro. / The Ribbed Decor does not guarantee continuity of the structure between pieces. / Bei dem Dekor Ribbed ist die Kontinuität der Linienstruktur zwischen einem Stück und dem nächsten nicht gewährleistet. / Le décor Ribbed ne garanti aucune continuité entre une pièce et l'autre.

6 mm

9 mm - RealUp + StrideUp



120x280x0,6 cm  
47 1/8"x110 1/8"x1/4"



80x160 cm  
31 1/2"x63"



120x120 cm  
47 1/8"x47 1/8"



60x120 cm  
23 1/2"x47 1/8"



60x60 cm  
23 1/2"x23 1/2"



30x60 cm  
11 1/8"x23 1/2"

Naturale / Matte	UGL	GRIGIO VEIN CUT	TR05XPA ■ 110				
RealUp + StrideUp	UGL	GRIGIO VEIN CUT		TR05GA ■ 078	TR05BA ■ 068		TR0563 ■ 052
		GRIGIO CROSS CUT		TR0612 ■ 078	TR06BA ■ 068	TR0668 ■ 052	TR0663 ■ 052
Ribbed	UGL	GRIGIO VEIN CUT			TR05BAR ■ 080		
		GRIGIO VEIN CUT			TR05BAA ■ 068		
Antislip	UGL	GRIGIO CROSS CUT			TR06BAA ■ 068		

Rosso Vein Cut



Rosso Vein Cut Ribbed

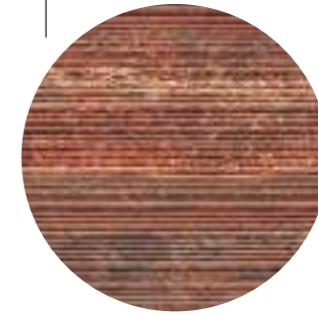

9 mm - StrideUp + RealUp



80x160 cm  
31 1/2"x63"



60x120 cm  
23 1/2"x47 1/8"

RealUp + StrideUp	UGL	ROSSO VEIN CUT	TR07GA ■ 078	TR07BA ■ 068
Ribbed	UGL	ROSSO VEIN CUT		TR07BAR ■ 080

Il Decoro Ribbed non garantisce continuità di struttura tra un pezzo e l'altro. / The Ribbed Decor does not guarantee continuity of the structure between pieces. / Bei dem Dekor Ribbed ist die Kontinuität der Linienstruktur zwischen einem Stück und dem nächsten nicht gewährleistet. / Le décor Ribbed ne garanti aucune continuité entre une pièce et l'autre.



Listello Tratto Rosso Vein Cut 20x120, Rosso Vein Cut 80x160, I Cementi Flax 120x280x0,6

## Decoro Radio 3D

Design Andrea Parisio  
& Giuseppe Pezzano

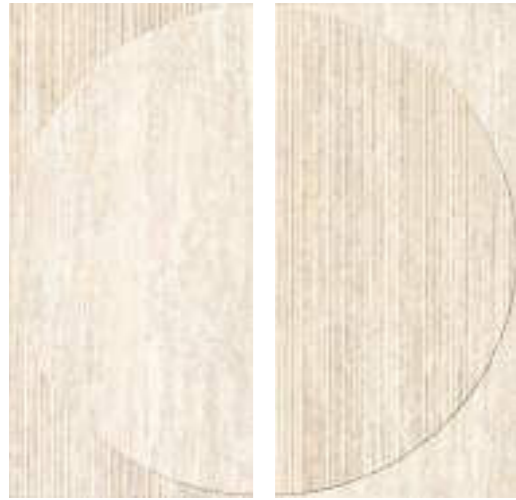

Bianco Vein Cut



Beige Vein Cut



Grigio Vein Cut



Rosso Vein Cut

### Schemi di posa / installation systems



Posa A



Posa B



Posa C



Posa D

## Decoro Radio 3D

Design Andrea Parisio  
& Giuseppe Pezzano

Ideato dagli architetti Andrea Parisio e Giuseppe Pezzano il decoro gioca con le geometrie circolari e verticali, generando combinazioni sempre diverse dalla forte connotazione grafica. Radio 3D abbina fondo vein cut e ribbed in due moduli complementari: la mezza luna interna è in rilievo rispetto al bordo, creando un modulo dall'effetto tridimensionale che valorizza ulteriormente i motivi geometrici.

Ogni scatola viene venduta contenente 2 pezzi che formano una composizione 120x120 cm.

Designed by architects Andrea Parisio and Giuseppe Pezzano, the decoration plays with circular and vertical geometries, generating ever-changing combinations with a strong graphic feature. Radio 3D combines the vein cut tile and the ribbed deco in two complementary modules: the internal half moon is in relief compared to the external portion of the piece, creating a module with a three-dimensional effect that further enhances the geometric motifs.

Each box is sold containing 2 pieces that form a composition 120x120 cm.

Die von den Architekten Andrea Parisio und Giuseppe Pezzano entworfene Dekoration spielt mit kreisförmigen und vertikalen Geometrien und erzeugt so immer wieder neue grafische Kombinationen. Radio 3D kombiniert die Untergründe Vein Cut und Ribbed in zwei komplementären Modulen: Der innere Halbmond hebt sich von der Kante ab, wodurch ein Modul mit dreidimensionaler Optik entsteht, die die geometrischen Muster noch verstärkt.

Jeder Verkaufskarton enthält 2 Platten, die eine 120x120 cm große Komposition bilden.

Conçue par les architectes Andrea Parisio et Giuseppe Pezzano, la décoration joue avec les formes circulaires et verticales pour générer des combinaisons toujours différentes offrant une forte connotation graphique. Radio 3D associe un fond Vein Cut et Ribbed en deux modules complémentaires : la demi-lune interne est en relief par rapport au bord et créé un effet tridimensionnel qui met encore plus en valeur les motifs géométriques.

Chaque boîte contient 2 pièces qui forment une composition de 120x120 cm.

**archiproducts**  
AWARDS  
WINNER

■ 9 mm  
RealUp + StrideUp - UGL



Decoro Radio 3D  
120x120  
47<sup>18</sup>x47<sup>14</sup>  
(Pcs Box 2)

BIANCO VEIN CUT	TR01DRD	■ 660
BEIGE VEIN CUT	TR03DRD	■ 660
GRIGIO VEIN CUT	TR05DRD	■ 660
ROSSO VEIN CUT	TR07DRD	■ 660

# Decoro Rilievo 3D

Design Andrea Parisio & Giuseppe Pezzano



**Bianco Vein Cut**  
20x120 - 20x120 inciso sul retro  
40x120 - 40x120 inciso sul retro

**Bianco Vein Cut**  
60x120



**Beige Vein Cut**  
20x120 - 20x120 inciso sul retro  
40x120 - 40x120 inciso sul retro

**Beige Vein Cut**  
60x120



**Grigio Vein Cut**  
20x120 - 20x120 inciso sul retro  
40x120 - 40x120 inciso sul retro

**Grigio Vein Cut**  
60x120



**Rosso Vein Cut**  
20x120 - 20x120 inciso sul retro  
40x120 - 40x120 inciso sul retro

**Rosso Vein Cut**  
60x120

■ 9 mm  
RealUp + StrideUp - UGL



Decoro Rilievo 3D  
120x120  
(20x120 2pz - 40x120 2pz)  
(8"x47 1/4" 2pcs - 15 3/4"x47 1/4" 2pcs)  
(Pcs Box 4)

<b>BIANCO VEIN CUT</b>	TR01DRL ■ 324
<b>BEIGE VEIN CUT</b>	TR03DRL ■ 324
<b>GRIGIO VEIN CUT</b>	TR05DRL ■ 324
<b>ROSSO VEIN CUT</b>	TR07DRL ■ 324

Le scatole dei listelli sono così composte / The listels boxes are composed as follows  
Jeder Karton besteht aus den folgenden Produkten / Les boîtes des listels sont composées par :

- 1 pezzo 20x120
- 1 pezzo 20x120 inciso sul retro / engraved on the back / auf der Rückseite eingepägt / gravé au dos
- 1 pezzo 40x120
- 1 pezzo 40x120 inciso sul retro / engraved on the back / auf der Rückseite eingepägt / gravé au dos

## Schemi di posa a 3 formati / Installation systems with 3 sizes

Per garantire un progetto di posa a regola d'arte, consigliamo uno schema random alternando - ai formati 20x120 e 40x120 - il fondo 60x120 cm.

To ensure a proper installation, we recommend a random pattern by alternating the 20x120cm (8"x48") and 40x120cm (32"x48") sizes with the 60x120cm (24"x48") field tile.

Um ein fachgerechtes Verlegebild zu gewährleisten, empfehlen wir ein zufälliges Schema, bei dem sich die Formate 20x120 und 40x120 mit den 60x120 Grundfliesen abwechseln.

Pour assurer u projet réalisé dans la règle de l'art, nous préconisons un schéma aléatoire en alternant aux formats 20x120 et 40x120 l'uni en 60x120.

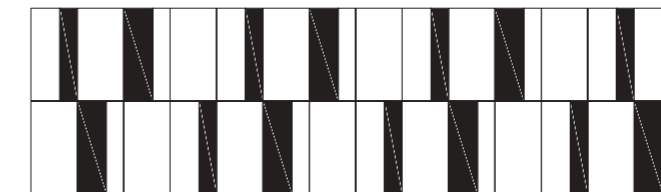

SIZES	20x120	60x120
	20x120 inciso sul retro / engraved on the back	
	40x120	
	40x120 inciso sul retro / engraved on the back	
% MQ	50%	50%

Nello schema accanto i formati incisi sul retro sono indicati dal colore nero.  
In the pattern beside, the sizes engraved on the back are indicated by the color black.  
In der nebenstehenden Abbildung sind die auf der Rückseite eingepägten Formate durch die Farbe Schwarz gekennzeichnet.  
Dans le tableau ici à coté, les formats gravés sur le dos sont indiqués en noir.

# Decoro Rilievo 3D

Design Andrea Parisio & Giuseppe Pezzano

Nell'immaginare questo decoro gli architetti Andrea Parisio e Giuseppe Pezzano si sono ispirati alla plasticità dei rivestimenti lapidei che caratterizzano l'architettura dei palazzi italiani. Rilievo 3D è un decoro che abbina un listello posato in modo planare ad un listello il cui lato maggiore viene posato in sovrapposizione, creando un modulo dall'originale effetto di tridimensionalità. Ciò è possibile grazie all'incisione effettuata sul retro, che in fase di installazione genera l'effetto 3D.

In imagining this decoration, the architects Andrea Parisio and Giuseppe Pezzano were inspired by the plasticity of the wall stone that characterize the architecture of Italian

buildings. The decoration combines a listel laid flatly with a listel which longer side is installed overlapping. This creates a module with an original three-dimensional effect. The overlapping is possible thanks to the engraving made on the back of the strip, which generates the 3D effect.

Bei der Realisierung dieses Dekors ließen sich die Architekten Andrea Parisio und Giuseppe Pezzano von der Plastizität der für italienische Gebäude typischen Natursteinverkleidungen inspirieren. Die Dekoration kombiniert einen planar verlegten Riemen mit einem weiteren Riemen, dessen längere Seite überlappend verlegt wird. So entsteht ein Modul mit

einer originellen dreidimensionalen Optik. Die Überlappung ist dank der Gravur auf der Rückseite des Riemens möglich, die bei der Verlegung die 3D-Optik erzeugt.

En imaginant cette décoration, les architectes Andrea Parisio et Giuseppe Pezzano se sont inspirés de la plasticité des revêtements en pierre caractéristiques de l'architecture des palais italiens. La décoration associe un listel posé à plat à un listel dont le grand côté est posé en superposition afin de créer un module offrant un effet tridimensionnel original. La superposition est possible grâce à l'incision effectuée à l'arrière du listel qui, lors de l'installation, génère l'effet 3D.

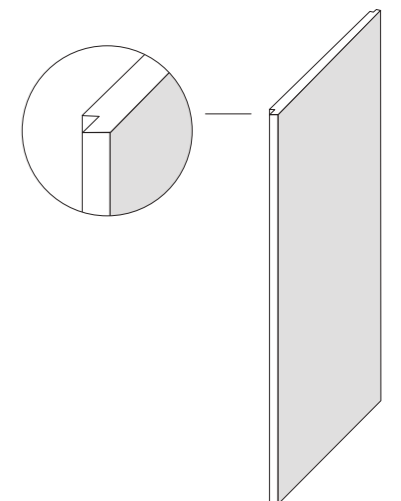

### Listello Tratto Vein Cut

20x120



Bianco Vein Cut  
6 mm / 9 mm



Beige Vein Cut  
6 mm / 9 mm



Grigio Vein Cut  
6 mm / 9 mm



Rosso Vein Cut  
9 mm

### Muretto Vein Cut

30x30



Bianco Vein Cut  
6 mm / 9 mm



Beige Vein Cut  
6 mm / 9 mm



Grigio Vein Cut  
6 mm / 9 mm



Rosso Vein Cut  
9 mm

### Muretto Cross Cut

30x30

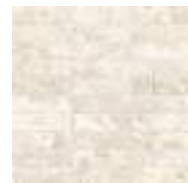

Bianco Cross Cut  
9 mm

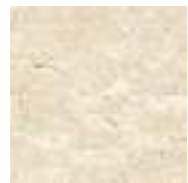

Beige Cross Cut  
9 mm



Grigio Cross Cut  
9 mm

### Mosaico Vein Cut

30x30



Bianco Vein Cut  
9 mm



Beige Vein Cut  
9 mm



Grigio Vein Cut  
9 mm



Rosso Vein Cut  
9 mm

### Mosaico Cross Cut

30x30



Bianco Cross Cut  
9 mm



Beige Cross Cut  
9 mm



Grigio Cross Cut  
9 mm

6 mm - Naturale / Matte - UGL

9 mm - RealUp + StrideUp - UGL



Listello Tratto  
20x120 cm  
8"x47 1/4"  
(Pcs Box 6)

Muretto  
30x30 cm  
11 7/8"x11 7/8"  
(Pcs Box 6)

Listello Tratto  
20x120 cm  
8"x47 1/4"  
(Pcs Box 6)

Muretto  
30x30 cm  
11 7/8"x11 7/8"  
(Pcs Box 6)

Mosaico  
30x30 cm  
11 7/8"x11 7/8"  
(Pcs Box 12)

<b>BIANCO VEIN CUT</b>	TR01LT 098	TR01MB 043	TR01LT9 064	TR01MB9 027	TR013MA 137
<b>BIANCO CROSS CUT</b>					TR023MA 137
<b>BEIGE VEIN CUT</b>	TR03LT 098	TR03MB 043	TR03LT9 064	TR03MB9 027	TR033MA 137
<b>BEIGE CROSS CUT</b>				TR04MB9 027	TR043MA 137
<b>GRIGIO VEIN CUT</b>	TR05LT 098	TR05MB 043	TR05LT9 064	TR05MB9 027	TR053MA 137
<b>GRIGIO CROSS CUT</b>				TR06MB9 027	TR063MA 137
<b>ROSSO VEIN CUT</b>			TR07LT9 064	TR07MB9 027	TR073MA 137



Su rete / Mesh mounted



Tessera  
2,5x120 1"x47 1/4"

Listello Tratto



Tessera  
2,8x9,8 1 1/8"x3 7/8"

Muretto



Tessera  
5x5 2"x2"

Mosaico

Pezzi speciali / Special pieces

**9 mm**

Color	RealUp + StrideUp	Antislip
BIANCO VEIN CUT	TR0176 ■ 009	TR0195I ■ 059
BIANCO CROSS CUT	TR0276 ■ 009	TR0295I ■ 059
BEIGE VEIN CUT	TR0376 ■ 009	TR0395I ■ 059
BEIGE CROSS CUT	TR0476 ■ 009	TR0495I ■ 059
GRIGIO VEIN CUT	TR0576 ■ 009	TR0595I ■ 059
GRIGIO CROSS CUT	TR0676 ■ 009	TR0695I ■ 059
ROSSO VEIN CUT	TR0776 ■ 009	



Download Catalogue

20 mm Open - Pezzi speciali / Special pieces

Per approfondimenti sui pezzi speciali e tutti gli accessori per esterno 20mm scarica la scheda tecnica oppure consultare il nostro sito e il catalogo Open.

For further information on special pieces and all 20mm outdoor accessories download the technical data sheet or consult our website and the Open catalog.

Für weitere Informationen zu Sonderteilen und dem gesamten 20mm Outdoor-Zubehör laden Sie das technische Datenblatt herunter oder besuchen Sie unsere Website und den Open-Katalog.

Pour approfondissements sur les pièces de finition et accessoires pour extérieurs en 20mm, merci de télécharger la fiche technique ou bien consulter notre site web et le catalogue OPEN.



Decoro Rilievo 3D Beige 20x120 + 40x120, Listello Tratto Beige Vein Cut 20x120, Ribbed Rosso Vein Cut 60x120, I Cementi Flax 120x120

Imballi / Packing

	PCS / BOX	M <sup>2</sup> / BOX	KG / BOX	BOX / PALLET	M <sup>2</sup> / PALLET	KG / PALLET
80x160 cm - 31 <sup>1/2</sup> "x62 <sup>7/8</sup> "	2	2,56	54,88	18	46,08	1.007,58
120x120 cm - 47 <sup>1/4</sup> "x47 <sup>1/4</sup> "	2	2,88	56,40	18	51,84	1.035,34
60x120 cm - 23 <sup>1/2</sup> "x47 <sup>1/4</sup> "	2	1,44	28,30	36	51,84	1.038,87
60x120 cm - 23 <sup>1/2</sup> "x47 <sup>1/4</sup> "	2	1,44	28,42	36	51,84	1.043,33
OPEN 60x120 cm - 23 <sup>1/2</sup> "x47 <sup>1/4</sup> "	1	0,72	32,40	36	25,92	1.186,65
60x60 cm - 23 <sup>1/2</sup> "x23 <sup>1/2</sup> "	4	1,44	28,19	30	43,20	865,73
30x60 cm - 11 <sup>7/8</sup> "x23 <sup>1/2</sup> "	8	1,44	28,44	32	46,08	930,20
Decoro Rilievo 3D 20x120 cm - 8"x47 <sup>1/4</sup> "	4	1,44	30,00	18	25,93	560,00
Decoro Radio 3D 120x120 cm - 47 <sup>1/4</sup> "x47 <sup>1/4</sup> "	2	1,44	30,00	10	14,40	320,00
Listello Tratto 20x120 cm - 8"x47 <sup>1/4</sup> "	6	1,44	19,15	30	43,20	594,74
Muretto 30x30 cm - 11 <sup>7/8</sup> "x11 <sup>7/8</sup> "	6	0,54	7,81	60	32,40	489,08
Muretto 30x30 cm - 11 <sup>7/8</sup> "x11 <sup>7/8</sup> "	6	0,54	10,20	60	32,40	632,00
Mosaico 30x30 cm - 11 <sup>7/8</sup> "x11 <sup>7/8</sup> "	12	1,08	20,62	30	32,40	638,60

Imballi Mega / Mega Packing

	DESCRIZIONE IMBALLO / PACKAGING DESCRIPTION	MQ / KG LASTRA / SLAB	IMBALLO PIENO / FULL PACKAGING	IMBALLO VUOTO / EMPTY PACKAGING
120x280x0,6 cm 47 <sup>1/4</sup> "x110 <sup>3/4</sup> "x1/4"	CASSA / CRATE L 145 x P 292 x H 35	MQ 3,36	MQ 67,20	
		KG 48,60	KG 1062,00	KG 100,00
120x280x0,6 cm 47 <sup>1/4</sup> "x110 <sup>3/4</sup> "x1/4"	CAVALLETTO / A-FRAME L 75 x P 285 x H 153	MQ 3,36	MQ 147,84	
		KG 48,60	KG 2318,40	KG 180,00
			PZ 44	
120x280x0,6 cm 47 <sup>1/4</sup> "x110 <sup>3/4</sup> "x1/4"	CASSA LIGHT / LIGHT CRATE L 145 x P 292 x H 27	MQ 3,36	MQ 30,24	
		KG 48,60	KG 527,40	KG 90,00
			PZ 1 / 9	

Stucchi consigliati / Recommended grouts

Colori / Colors	Bianco Vein Cut / Cross Cut	Beige Vein Cut / Cross Cut	Grigio Vein Cut / Cross Cut	Rosso Vein Cut
Kerakoll	KK76	KK107	KK109	KK156
Mapei	80% 100 + 20% 110	80% 100 + 20% 132	111	70% 142 + 30% 143

Le tipologie di stucchi riportate nella tabella sono semplici suggerimenti. Prima della posa si raccomanda di eseguire un test di stuccatura per verificarne la compatibilità con la superficie ceramica e le condizioni di utilizzo. / The types of grout listed in the table are simply suggestions. Before installation, it is recommended to perform a grouting test to verify compatibility with the ceramic surface and conditions of use. / Die in der Tabelle aufgeführten Fugenmörteltypen sind lediglich Empfehlungen. Vor dem Verlegen wird empfohlen, einen Fugentest durchzuführen, um die Verträglichkeit mit der Keramikoberfläche und den Einsatzbedingungen zu überprüfen. / Les types de mastics indiqués dans le tableau sont de simples suggestions. Avant la pose, il est recommandé d'effectuer un test de masticage afin de vérifier la compatibilité avec la surface céramique et les conditions d'utilisation.



Charm Experience, Calacatta Black 120x280x0,6, Nuances Nero 120x120, Loom Piano Angle 110

# Marble

Gres porcellanato - Rettificato / Porcelain Stoneware - Rectified  
Feinsteinzeug - Kalibriert / Gres Cerame - Rectifié

Conforming to Standards

EN 14411 ISO 13006 APPENDICE G GRUPPO BIa UGL CON Ev ≤ 0,5%

\* EN 14411 ISO 13006 APPENDICE G GRUPPO BIa GL CON Ev ≤ 0,5%



Download  
Marble

Caratteristiche tecniche  
Technical features

BENDING STRENGTH	FROST RESISTANCE	CHEMICAL RESISTANCE	STAIN RESISTANCE		
ANSI A326.3 > 0,42	TRAFFICO MEDIO MEDIUM TRAFFIC	TRAFFICO INTENSO HEAVY TRAFFIC	V2 MODERATE	V3 HIGH	UNITÀ DI BRILLANTEZZA GLOSS UNIT
Naturale / Matte Fade	Lappato / Polished	Naturale / Matte Fade	Amazonite Blu Saint Laurent Calacatta Black Calacatta Mont Blanc Orobico Grey Sahara Noir Pietra Grey	Calacatta Gold Calacatta Green Calacatta Pink Statuario Lux	Lappato > 80 Very Glossy Surface All Colours

Formati  
Sizes

<b>SUPERFICIE SURFACE</b>	120x280x0,6 cm 47 <sup>1/4</sup> "x110 <sup>1/4</sup> "x1/4"	160x320x1,2 cm 62 <sup>7/8</sup> "x125 <sup>3/4</sup> "x1/2"	120x120 cm 47 <sup>1/4</sup> "x47 <sup>1/4</sup> "	60x120 cm 23 <sup>1/2</sup> "x47 <sup>1/4</sup> "	60x60 cm 23 <sup>1/2</sup> "x23 <sup>1/2</sup> "
Naturale / Matte Natur / Naturel	■	■	■	■	■
*Lappato / Polished Anpoliert / Adouci	■	■	■	■	■
Seta / Silk		■			
Fade				■	

Colori  
Colours

Marble Experience		Lux Experience	Charm Experience		
Statuario Lux	Calacatta Gold	Calacatta Mont Blanc	Calacatta Pink	Calacatta Green	Calacatta Black
Orobico Grey	Sahara Noir	Pietra Grey	Amazonite	Blu Saint Laurent	

Superficie  
Surface finishes

Naturale Matte	*Lappato Polished	Fade



Charm Experience, Blu Saint Laurent 120x280x0,6, Nuances Nero 120x280x0,6, Listello Tratto 20x120



Marble Experience, Sahara Noir, Calacatta Gold 120x280x0,6



Lux Experience, Calacatta Mont Blanc Lappato 120x280x0,6



Lux Experience, Pietra Grey Lappato 120x280x0,6

# Calacatta Gold

Marble Experience



Vena Continua 6 lastre 120x280x0,6  
Continuous veining 6 slabs 120x280x0,6



Il disegno riprodotto è indicativo. Come per il materiale naturale anche la grafica di Vena Continua può mostrare discontinuità di vena nel passaggio da una lastra all'altra. Per questo motivo differenze fino a 1,5 cm devono essere considerate come caratteristica del prodotto.

The reproduced pattern is indicative. As with natural material, continuous vein graphics can also show discontinuities from one slab to another. For this reason, differences of up to 1.5 Cm must be considered as a product characteristic.

Das reproduzierte Design ist nur richtungsweisend. Wie beim natürlichen Material können auch die Grafiken der durchgehenden Maserungen Aderbrüche beim Übergang von einer Platte zur anderen aufweisen. Aus diesem Grund müssen Unterschiede von bis zu 1,5 cm als Produktmerkmal betrachtet werden.

Le dessin reproduit est à titre illustratif. Comme pour le matériau naturel, le dessin à veine continue peut présenter une discontinuité des veines entre deux dalles. Pour cette raison, des différences jusqu'à 1,5 cm doivent être considérées comme une caractéristique du produit.

6 mm	12 mm	9 mm
120x280x0,6 cm 47 <sup>11/16</sup> x 110 <sup>11/16</sup> x 1/4"	160x320x1,2 cm 62 <sup>11/16</sup> x 125 <sup>3/4</sup> x 1/2"	120x120 cm 47 <sup>11/16</sup> x 47 <sup>11/16</sup>
		60x120 cm 23 <sup>11/16</sup> x 47 <sup>11/16</sup>
		60x60 cm 23 <sup>11/16</sup> x 23 <sup>11/16</sup>

Naturale / Matte	UGL	MB02XPA ■ 110			MB02BA ■ 068	MB0268 ■ 052
Naturale Vena Continua / Matte Continuous Veining	UGL	MBV2XPA ■ 135				
Seta / Silk	UGL		A LM15AXA12 ■ 272			
			B LM15BXA12 ■ 272			
Lappato / Polished	GL	MB02XPL ■ 140		A LM15AXL12 ■ 330	MB0212L ■ 115	MB02BAL ■ 095
			B LM15BXL12 ■ 330			
Lappato Vena Continua / Polished Continuous Veining	GL	MBV2XPL ■ 170				

# Statuario Lux

Marble Experience



Vena Continua 6 lastre 120x280x0,6  
Continuous veining 6 slabs 120x280x0,6

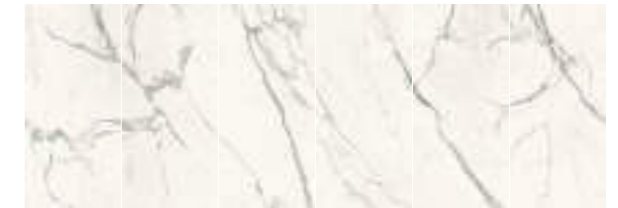

Il disegno riprodotto è indicativo. Come per il materiale naturale anche la grafica di Vena Continua può mostrare discontinuità di vena nel passaggio da una lastra all'altra. Per questo motivo differenze fino a 1,5 cm devono essere considerate come caratteristica del prodotto.

The reproduced pattern is indicative. As with natural material, continuous vein graphics can also show discontinuities from one slab to another. For this reason, differences of up to 1.5 Cm must be considered as a product characteristic.

Das reproduzierte Design ist nur richtungsweisend. Wie beim natürlichen Material können auch die Grafiken der durchgehenden Maserungen Aderbrüche beim Übergang von einer Platte zur anderen aufweisen. Aus diesem Grund müssen Unterschiede von bis zu 1,5 cm als Produktmerkmal betrachtet werden.

Le dessin reproduit est à titre illustratif. Comme pour le matériau naturel, le dessin à veine continue peut présenter une discontinuité des veines entre deux dalles. Pour cette raison, des différences jusqu'à 1,5 cm doivent être considérées comme une caractéristique du produit.

6 mm	12 mm	9 mm
120x280x0,6 cm 47 <sup>11/16</sup> x 110 <sup>11/16</sup> x 1/4"	160x320x1,2 cm 62 <sup>11/16</sup> x 125 <sup>3/4</sup> x 1/2"	120x120 cm 47 <sup>11/16</sup> x 47 <sup>11/16</sup>
		60x120 cm 23 <sup>11/16</sup> x 47 <sup>11/16</sup>
		60x60 cm 23 <sup>11/16</sup> x 23 <sup>11/16</sup>

Naturale / Matte	UGL	MB01XPA ■ 110			MB01BA ■ 068	MB0168 ■ 052
Naturale Vena Continua / Matte Continuous Veining	UGL	MBV1XPA ■ 135				
Seta / Silk	UGL		A LM20AXA12 ■ 242			
			B LM20BXA12 ■ 242			
Lappato / Polished	GL	MB01XPL ■ 140		A LM20AXL12 ■ 300	MB0112L ■ 115	MB01BAL ■ 095
			B LM20BXL12 ■ 300			
Lappato Vena Continua / Polished Continuous Veining	GL	MBV1XPL ■ 170				

Calacatta Pink  
Charm Experience



Vena Continua 6 lastre 120x280x0,6  
Continuous veining 6 slabs 120x280x0,6



Il disegno riprodotto è indicativo. Come per il materiale naturale anche la grafica di Vena Continua può mostrare discontinuità di vena nel passaggio da una lastra all'altra. Per questo motivo differenze fino a 1,5 cm devono essere considerate come caratteristica del prodotto.

The reproduced pattern is indicative. As with natural material, continuous vein graphics can also show discontinuities from one slab to another. For this reason, differences of up to 1.5 cm must be considered as a product characteristic.

Das reproduzierte Design ist nur richtungsweisend. Wie beim natürlichen Material können auch die Grafiken der durchgehenden Maserungen Aderbrüche beim Übergang von einer Platte zur anderen aufweisen. Aus diesem Grund müssen Unterschiede von bis zu 1,5 cm als Produktmerkmal betrachtet werden.

Le dessin reproduit est à titre illustratif. Comme pour le matériau naturel, le dessin à veine continue peut présenter une discontinuité des veines entre deux dalles. Pour cette raison, des différences jusqu'à 1,5 cm doivent être considérées comme une caractéristique du produit.

6 mm 9 mm



120x280x0,6 cm  
47<sup>11/16</sup>"x110<sup>1/4</sup>"x1/4"



60x120 cm  
23<sup>1/2</sup>"x47<sup>1/4</sup>"

Lappato / Polished GL CH01XPL 140 CH01BAL 095

Lappato Vena Continua / Polished Continuous Veining GL CHVIXPL 170

Calacatta Green  
Charm Experience



9 mm 12 mm

60x120 cm  
23<sup>1/2</sup>"x47<sup>1/4</sup>"



160x320x1,2 cm  
62<sup>7/8</sup>"x125<sup>3/4</sup>"x1/2"

Naturale / Matte UGL CH02XXA12S 242

Lappato / Polished GL CH02BAL 095 CH02XXL12S 300

Amazzonite  
Charm Experience



Blu Saint Laurent  
Charm Experience



Calacatta Mont Blanc  
Lux Experience



Pietra Grey  
Lux Experience



6 mm 9 mm

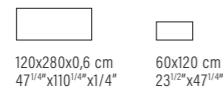

Lappato / Polished	GL	AMAZZONITE	CH05XPL ■ 140	CH05BAL ■ 095
		BLU SAINT LAURENT	CH06XPL ■ 140	CH06BAL ■ 095

6 mm 12 mm 9 mm

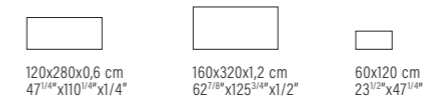

Naturale / Matte	UGL	CALACATTA MONT BLANC	MW05XPA ■ 110	PIETRA GREY	MW02XPA ■ 110	MW02XXA12S ■ 242	
		Seta / Silk			A LM14AXA12 ■ 242		
					B LM14BXA12 ■ 242		
		Fade					MW05BAFA ■ 068
							MW02BAFA ■ 068
		Lappato / Polished					
			A LM14AXL12 ■ 300				MW05BAL ■ 095
			B LM14BXL12 ■ 300				
					MW02XXL12S ■ 300		MW02BAL ■ 095

Orobico Grey  
Marble Experience



Calacatta Black  
Charm Experience



Sahara Noir  
Marble Experience

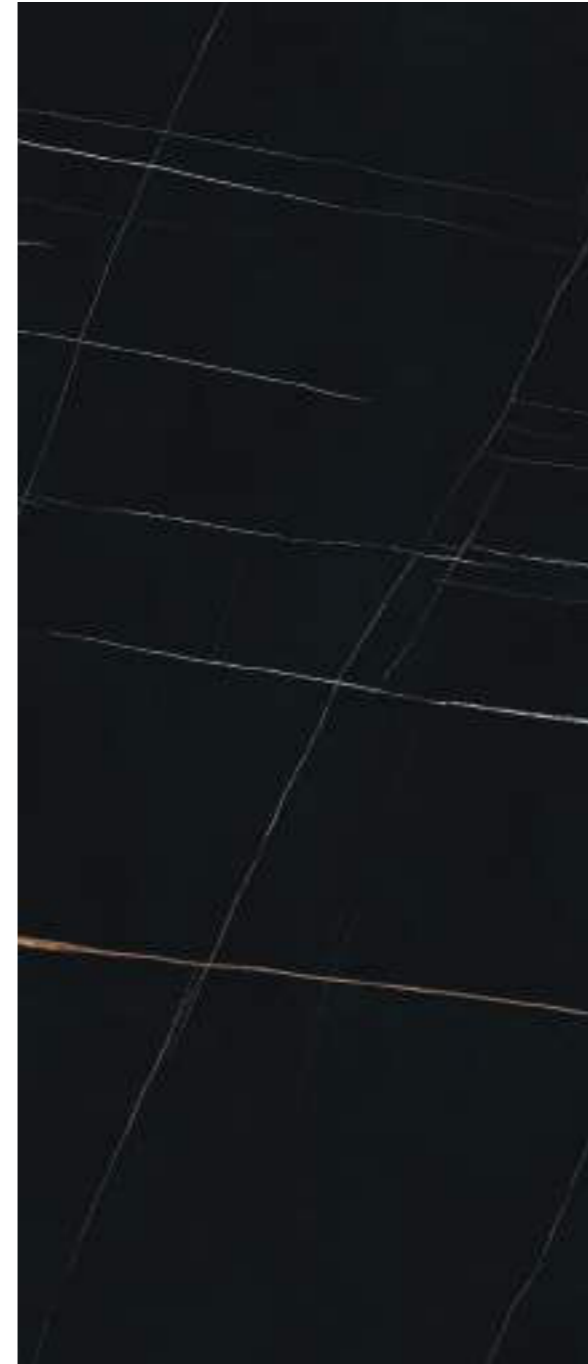

	6 mm	12 mm	9 mm		
	120x280x0,6 cm 47 <sup>11/16</sup> "x110 <sup>1/4</sup> "x1/4"	160x320x1,2 cm 62 <sup>7/8</sup> "x125 <sup>3/4</sup> "x1/2"	120x120 cm 47 <sup>11/16</sup> "x47 <sup>11/16</sup> "	60x120 cm 23 <sup>1/2</sup> "x47 <sup>11/16</sup> "	60x60 cm 23 <sup>1/2</sup> "x23 <sup>1/2</sup> "
Naturale / Matte UGL	OROBICO GREY			MB03BA ■ 068	MB0368 ■ 052
	CALACATTA BLACK	CH03XXA12S ■ 242		CH03BA ■ 068	
Lappato / Polished GL	OROBICO GREY	MB03XPL ■ 140		MB03BAL ■ 095	
	CALACATTA BLACK	CH03XPL ■ 140	CH0312L ■ 115	CH03BAL ■ 095	

	6 mm	12 mm	9 mm		
	120x280x0,6 cm 47 <sup>11/16</sup> "x110 <sup>1/4</sup> "x1/4"	160x320x1,2 cm 62 <sup>7/8</sup> "x125 <sup>3/4</sup> "x1/2"	120x120 cm 47 <sup>11/16</sup> "x47 <sup>11/16</sup> "	60x120 cm 23 <sup>1/2</sup> "x47 <sup>11/16</sup> "	60x60 cm 23 <sup>1/2</sup> "x23 <sup>1/2</sup> "
Naturale / Matte UGL	SAHARA NOIR	A MB4AXXA12S ■ 242		MB04BA ■ 068	MB0468 ■ 052
		B MB4BXXA12S ■ 242			
Lappato / Polished GL	SAHARA NOIR	MB04XPL ■ 140		MB04BAL ■ 095	

### Listello Tratto

Charm Experience

20x120

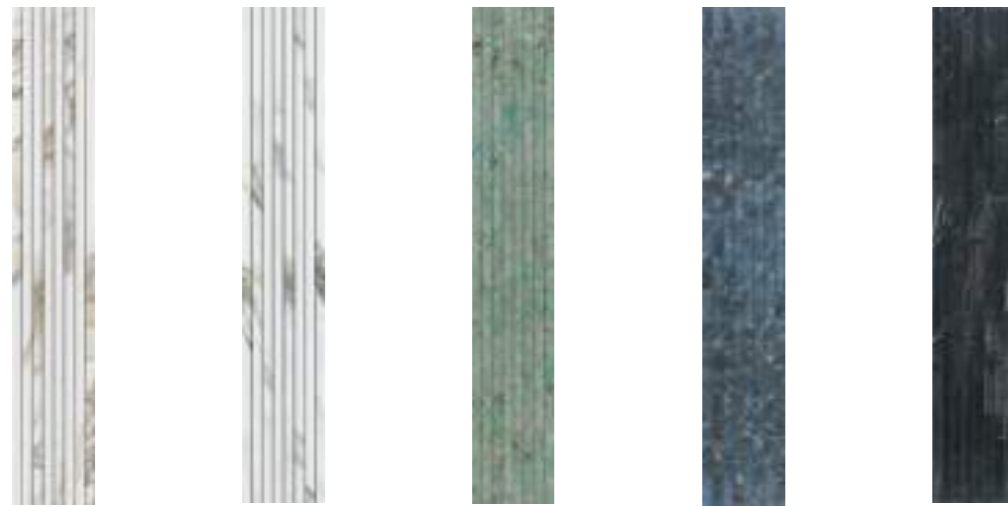

Calacatta Pink Calacatta Green Amazonite Blu Saint Laurent Calacatta Black

### Muretto

Charm Experience

30x30



Calacatta Pink Calacatta Green Amazonite Blu Saint Laurent Calacatta Black

### Mosaico

Charm Experience

30x30



Calacatta Pink Calacatta Green Amazonite Blu Saint Laurent Calacatta Black

### Mosaico Rombi

Charm Experience

31x33,5



Calacatta Pink Calacatta Green Calacatta Black Amazonite Blu Saint Laurent

### Mosaico Ovale

Charm Experience

19,5x37



Calacatta Pink Calacatta Green Amazonite Blu Saint Laurent Calacatta Black

### Mosaico Ovale Mix

Charm Experience

19,5x37



MIX 1 Calacatta Pink, Fiamma  
MIX 2 Calacatta Green, Salvia

6 mm  
Lappato / Polished - GL



Listello Tratto  
20x120 cm  
8"x47 1/4"  
(Pcs Box 6)



Muretto  
30x30 cm  
11 7/8"x11 7/8"  
(Pcs Box 6)

9 mm  
Lappato / Polished - GL



Mosaico Rombi  
31x33,5 cm  
12 3/16"x13 3/16"  
(Pcs Box 6)



Mosaico  
30x30 cm  
11 7/8"x11 7/8"  
(Pcs Box 12)



Mosaico Ovale  
19,5x37 cm  
4"x14 5/8"  
(Pcs Box 6)



Mosaico Ovale Mix  
19,5x37 cm  
4"x14 5/8"  
(Pcs Box 6)

<b>CALACATTA PINK</b>	CH01LTL ■ 112	CH01MBL ■ 047
<b>CALACATTA GREEN</b>	CH02LTL ■ 112	CH02MBL ■ 047
<b>CALACATTA BLACK</b>	CH03LTL ■ 112	CH03MBL ■ 047
<b>AMAZONITE</b>	CH05LTL ■ 112	CH05MBL ■ 047
<b>BLU SAINT LAURENT</b>	CH06LTL ■ 112	CH06MBL ■ 047

CH01MRBL ■ 052	CH013ML ■ 193	CH01MOVL ■ 049
CH02MRBL ■ 052	CH023ML ■ 193	CH02MOVL ■ 049
CH03MRBL ■ 052	CH033ML ■ 193	CH03MOVL ■ 049
CH05MRBL ■ 052	CH053ML ■ 193	CH05MOVL ■ 049
CH06MRBL ■ 052	CH063ML ■ 193	CH06MOVL ■ 049

<b>MIX 1</b>	CH01MOVLX ■ 049
<b>MIX 2</b>	CH02MOVLX ■ 049



Su rete / Mesh mounted



Tessera  
2,5x120 1"x47 1/4"



Tessera  
2,8x9,8 1 1/8"x3 7/8"



Tessere  
1,5x15 1/2"x6"



Tessera  
5x5 2"x2"



Tessera  
4,7x18,7 1 7/8"x7 3/8"

**Mosaico Esagona Decoro Mix**  
Lux Experience  
20x34



Calacatta Mont Blanc Pietra Grey

**Mosaico Esagona Allungato Mix**  
Lux Experience  
25,5x29,5



Calacatta Mont Blanc Pietra Grey

**Mosaico Esagona Fade**  
Lux Experience  
26x30



Calacatta Mont Blanc Pietra Grey

**Mosaico Basketwave Fade**  
Lux Experience  
30x30



Calacatta Mont Blanc\* Pietra Grey\*\*



■ 9 mm - Mix Superfici / Mix surfaces



Mosaico Esagona Decoro Mix  
20x34  
8"x13<sup>3/8"</sup>  
(Pcs Box 6)



Mosaico Esagona Allungato Mix  
25,5x29,5 cm  
10<sup>1/4"</sup>x11<sup>7/8"</sup>  
(Pcs Box 6)

■ 9 mm - Fade - UGL



Mosaico Esagona  
26x30 cm  
10<sup>1/4"</sup>x11<sup>7/8"</sup>  
(Pcs Box 10)



Mosaico Basketwave  
30x30 cm  
11<sup>7/8"</sup>x11<sup>7/8"</sup>  
(Pcs Box 10)

<b>CALACATTA MONT BLANC</b>	MW05MEDM	047	MW05MESAM	053	MW05MESFA	038	MW05MBWFA	024
<b>PIETRA GREY</b>	MW02MEDM	047	MW02MESAM	053	MW02MESFA	038	MW02MBWFA	024

\* Bocciardato / Lappato / Fade / Rullato / Spazzolato  
\*\* Lappato / Fade



Su rete / Mesh mounted



Tessera  
11,5x12,5 4<sup>1/2"</sup>x5"

Mosaico Esagona Decoro Mix



Tessera  
10x5,5 4"x2<sup>1/8"</sup>

Mosaico Esagona Allungato Mix



Tessera  
7,3x8,4 2<sup>7/8"</sup>x3<sup>3/16"</sup>

Mosaico Esagona



Tessera  
6x10 2<sup>3/8"</sup>x4"

Mosaico Basketwave

Lux Experience, Mosaico Esagona Allungato Mix 25,5x29,5

Pezzi speciali / Special pieces

		9 mm			
		Battiscopa 7x60 cm 2 <sup>3/4</sup> "x23 <sup>1/2</sup> " (Pcs Box 10)	Gradone con Toro 60x33x4 cm 23 <sup>1/2</sup> "x13 <sup>1/2</sup> "x1 <sup>1/4</sup> " (Pcs Box 4)	Gradone con Toro 120x33x4 cm 47 <sup>1/4</sup> "x13 <sup>1/2</sup> "x1 <sup>1/4</sup> " (Pcs Box 2)	
CALACATTA GOLD	Marble Experience	Naturale / Matte	MB0276 ■ 009	MB02G3S ■ 113	MB02GT2 ■ 223
		Lappato / Polished	MB0276L ■ 014	MB02G3L ■ 137	MB02GT3 ■ 261
STATUARIO LUX	Marble Experience	Naturale / Matte	MB0176 ■ 009	MB01G3S ■ 113	MB01GT2 ■ 223
		Lappato / Polished	MB0176L ■ 014	MB01G3L ■ 137	MB01GT3 ■ 261
SAHARA NOIR	Marble Experience	Naturale / Matte	MB0476 ■ 009	MB04G3S ■ 113	MB04GT2 ■ 223
		Lappato / Polished	MB0476L ■ 014	MB04G3L ■ 137	MB04GT3 ■ 261
OROBICO GREY	Marble Experience	Naturale / Matte	MB0376 ■ 009	MB03G3S ■ 113	MB03GT2 ■ 223
		Lappato / Polished	MB0376L ■ 014	MB03G3L ■ 137	MB03GT3 ■ 261
CALACATTA PINK	Charm Experience	Lappato / Polished	CH0176L ■ 014		CH01GT3 ■ 261
CALACATTA GREEN	Charm Experience	Lappato / Polished	CH0276L ■ 014		CH02GT3 ■ 261
AMAZZONITE	Charm Experience	Lappato / Polished	CH0576L ■ 014		CH05GT3 ■ 261
BLU SAINT LAURENT	Charm Experience	Lappato / Polished	CH0676L ■ 014		CH06GT3 ■ 261
CALACATTA BLACK	Charm Experience	Naturale / Matte	CH0376 ■ 009		CH03GT2 ■ 223
		Lappato / Polished	CH0376L ■ 014		CH03GT3 ■ 261
CALACATTA MONT BLANC	Lux Experience	Fade	MW0576FA ■ 009		MW02GT9 ■ 223
		Lappato / Polished	MW0576L ■ 014		MW02GT3 ■ 261
PIETRA GREY	Lux Experience	Fade	MW0276FA ■ 009		MW05GT9 ■ 223
		Lappato / Polished	MW0276L ■ 014		MW05GT3 ■ 261

Stucchi consigliati / Recommended grouts

Colori Colors	Statuario Lux	Calacatta Gold	Orobico Grey	Sahara Noir	Calacatta Mont Blanc	Pietra Grey	Calacatta Pink	Calacatta Green	Calacatta Black	Blu Saint Laurent	Amazonite
Kerakoll	KK4	KK4	KK68	KK12	KK64	KK10	KK4	KK4	KK72	80% KK29 + 20% KK72	KK50
Mapei	103	70% 100 + 30% 110	112	70% 114 + 30% 120	60% 100 + 40% 110	70% 114 + 30% 110	103	103	120	90% 172 + 10% 120	112

Le tipologie di stucchi riportate nella tabella sono semplici suggerimenti. Prima della posa si raccomanda di eseguire un test di stuccatura per verificare la compatibilità con la superficie ceramica e le condizioni di utilizzo. / The types of grout listed in the table are simply suggestions. Before installation, it is recommended to perform a grouting test to verify compatibility with the ceramic surface and conditions of use. / Die in der Tabelle aufgeführten Fugenmörteltypen sind lediglich Empfehlungen. Vor dem Verlegen wird empfohlen, einen Fugentest durchzuführen, um die Verträglichkeit mit der Keramikoberfläche und den Einsatzbedingungen zu überprüfen. / Les types de mortiers indiqués dans le tableau sont de simples suggestions. Avant la pose, il est recommandé d'effectuer un test de masticage afin de vérifier la compatibilité avec la surface céramique et les conditions d'utilisation.

Imballi / Packing

					PCS / BOX	M <sup>2</sup> / BOX	KG / BOX	BOX / PALLET	M <sup>2</sup> / PALLET	KG / PALLET
	120x120 cm - 47 <sup>1/4</sup> "x47 <sup>1/4</sup> "	Charm, Marble Experience	Thick 9 mm	Lappato	PZ / PCS 02	M <sup>2</sup> 2,88	KG 60,33	PZ / PCS 18	M <sup>2</sup> 51,84	KG 1.105,94
	60x120 cm - 23 <sup>1/2</sup> "x47 <sup>1/4</sup> "	Charm, Marble, Lux Experience	Thick 9 mm	Naturale Lappato / Fade	PZ / PCS 02	M <sup>2</sup> 1,44	KG 30,64	PZ / PCS 36	M <sup>2</sup> 51,84	KG 1.123,36
	60x60 cm - 23 <sup>1/2</sup> "x23 <sup>1/2</sup> "	Marble Experience	Thick 9 mm	Naturale Lappato	PZ / PCS 04	M <sup>2</sup> 1,44	KG 27,40	PZ / PCS 30	M <sup>2</sup> 43,20	KG 842,27
	Listello Tratto 20x120 cm - 8"x47 <sup>1/4</sup> "	Charm Experience	Thick 6 mm	Lappato	PZ / PCS 06	M <sup>2</sup> 1,44	KG 20,10	PZ / PCS 30	M <sup>2</sup> 43,20	KG 623,00
	Muretto 30x30 cm - 11 <sup>7/8</sup> "x11 <sup>7/8</sup> "	Charm Experience	Thick 6 mm	Lappato	PZ / PCS 06	M <sup>2</sup> 0,54	KG 7,39	PZ / PCS -	M <sup>2</sup> -	KG -
	Mosaico Ovale 19,5x37 cm - 4"x14 <sup>5/8</sup> "	Charm Experience	Thick 9 mm	Lappato	PZ / PCS 06	M <sup>2</sup> 0,43	KG 8,62	PZ / PCS 60	M <sup>2</sup> 25,92	KG 537,32
	Mosaico Rombi 31x33,5 cm - 12 <sup>3/16</sup> "x13 <sup>3/16</sup> "	Charm Experience	Thick 9 mm	Lappato	PZ / PCS 06	M <sup>2</sup> 0,62	KG 9,76	PZ / PCS 60	M <sup>2</sup> 37,44	KG 605,72
	Mosaico 30x30 cm - 11 <sup>7/8</sup> "x11 <sup>7/8</sup> "	Charm Experience	Thick 9 mm	Lappato	PZ / PCS 12	M <sup>2</sup> 1,08	KG 24,59	PZ / PCS 30	M <sup>2</sup> 32,40	KG 757,76
	Mosaico Basketwave 30x30 cm - 8"x8"	Lux Experience	Thick 9 mm	Fade	PZ / PCS 10	M <sup>2</sup> 0,90	KG 18,50	PZ / PCS 30	M <sup>2</sup> 27,00	KG 515,00
	Mosaico Esagona Fade 26x30 cm - 10 <sup>1/8</sup> "x11 <sup>7/8</sup> "	Lux Experience	Thick 9 mm	Fade	PZ / PCS 10	M <sup>2</sup> 0,78	KG 15,72	PZ / PCS 30	M <sup>2</sup> 23,40	KG 491,60
	Mosaico Esagona Allungato Mix 25,5x29,5 cm - 10"x11 <sup>5/8</sup> "	Lux Experience	Thick 9 mm	Mix Superfici	PZ / PCS 06	M <sup>2</sup> 0,45	KG 8,50	PZ / PCS 60	M <sup>2</sup> 27,00	KG 530,00
	Mosaico Esagona Decoro Mix 20x34 cm - 8"x13 <sup>3/8</sup> "	Lux Experience	Thick 9 mm	Mix Superfici	PZ / PCS 06	M <sup>2</sup> 0,40	KG 8,00	PZ / PCS 60	M <sup>2</sup> 24,48	KG 499,88

Imballi Mega / Mega Packing

	DESCRIZIONE IMBALLO PACKAGING DESCRIPTION	MQ / KG LASTRA / SLAB	IMBALLO PIENO FULL PACKAGING	IMBALLO VUOTO EMPTY PACKAGING	
	120x280x0,6 cm 47 <sup>1/4</sup> "x110 <sup>1/4</sup> "x1/4"		CASSA / CRATE L 145 x P 292 x H 34	MQ 3,36	MQ 67,20
				KG 48,60	KG 1.062,00
	120x280x0,6 cm 47 <sup>1/4</sup> "x110 <sup>1/4</sup> "x1/4"		CAVALLETTO / A-FRAME L 75 x P 285 x H 153	MQ 3,36	MQ 147,84
				KG 48,60	KG 2.318,40
	120x280x0,6 cm 47 <sup>1/4</sup> "x110 <sup>1/4</sup> "x1/4"		CASSA LIGHT / LIGHT CRATE L 145 x P 292 x H 27	MQ 3,36	MQ 30,24
				KG 48,60	KG 527,40
				PZ 1 / 9	

Pag. 415: approfondimenti calibri specifici / Pag. 415: further information on specific working sizes / S. 415: Vertiefungen über spezifische Werkmaße / Pag. 415: approfondissements dimensions de fabrication spécifiques

**120 Stone Effect**

- 122 Natural
- 142 Dorset
- 160 Origins
- 178 Shale
- 192 Silver Grain + Ceppo di Gré
- 208 Nordic Stone
- 214 Stone Mix



# Natural

Gres porcellanato - Rettificato / Porcelain Stoneware - Rectified  
Feinsteinzeug - Kalibriert / Gres Cerame - Rectifié

New Innovative  
Technology



Download  
Catalogue

Conforming to Standards  
EN 14411 ISO 13006 APPENDICE G GRUPPO BIa UGL CON Ev ≤ 0,5%

RealUp®  
StrideUp®

Caratteristiche tecniche  
Technical features

BENDING STRENGTH	FROST RESISTANCE	CHEMICAL RESISTANCE	STAIN RESISTANCE	
ANSI A326.3 > 0,42	R10 / A+B	R11 / A+B+C	TRAFFICO INTENSO HEAVY TRAFFIC	V2 MODERATE
RealUp RealUp + StrideUp OPEN	RealUp + StrideUp	Antislip OPEN	Naturale / Matte RealUp + StrideUp Antislip OPEN	All Colours

Formati  
Sizes

<b>SUPERFICIE SURFACE</b>	120x280x0,6 cm 47 <sup>1/4</sup> "x110 <sup>1/4</sup> "x1/4"	80x160 cm 31 <sup>1/2</sup> "x63"	120x120 cm 47 <sup>1/4</sup> "x47 <sup>1/4</sup> "	80x80 cm 31 <sup>1/2</sup> "x31 <sup>1/2</sup> "
	60x120 cm 23 <sup>1/2</sup> "x47 <sup>1/4</sup> "	60x60 cm 23 <sup>1/2</sup> "x23 <sup>1/2</sup> "	30x60 cm 11 <sup>7/8</sup> "x23 <sup>1/2</sup> "	60x120 cm 23 <sup>1/2</sup> "x47 <sup>1/4</sup> "
RealUp	■			
RealUp + StrideUp	■	■	■	■
Stripe			■	
Antislip		■	■	■

Colori  
Colours

White	Beige	Ivory	Flax	Greige	Argil	Moka	Dark

Superficie  
Surface finishes

RealUp	RealUp + StrideUp	Stripe	Antislip

Natural Dark 120x280x0,6, I Cementi Black Listello Tratto 20x120, I Cementi Argil 120x120



I Cementi Ivory 120x280x0,6, I Cementi Black Listello Tratto 20x120, I Cementi Argil 120x120, Natural Dark 120x280x0,6



Natural Beige 60x120 20 mm, I Cementi Ivory 120x280x0,6



Beige 120x280x0,6, Moka Listello Tratto 20x120, Flax 120x280x0,6, 60x120 20 mm

White



White Stripe

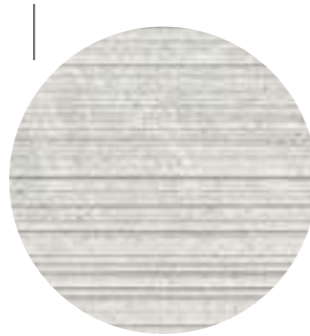

Il Decoro Stripe non garantisce continuità di struttura tra un pezzo e l'altro. / The Stripe Decor does not guarantee continuity of the structure between pieces. / Bei dem Dekor Stripe ist die Kontinuität der Linienstruktur zwischen einem Stück und dem nächsten nicht gewährleistet. / Le décor Stripe ne garanti aucune continuité entre une pièce et l'autre.

Beige

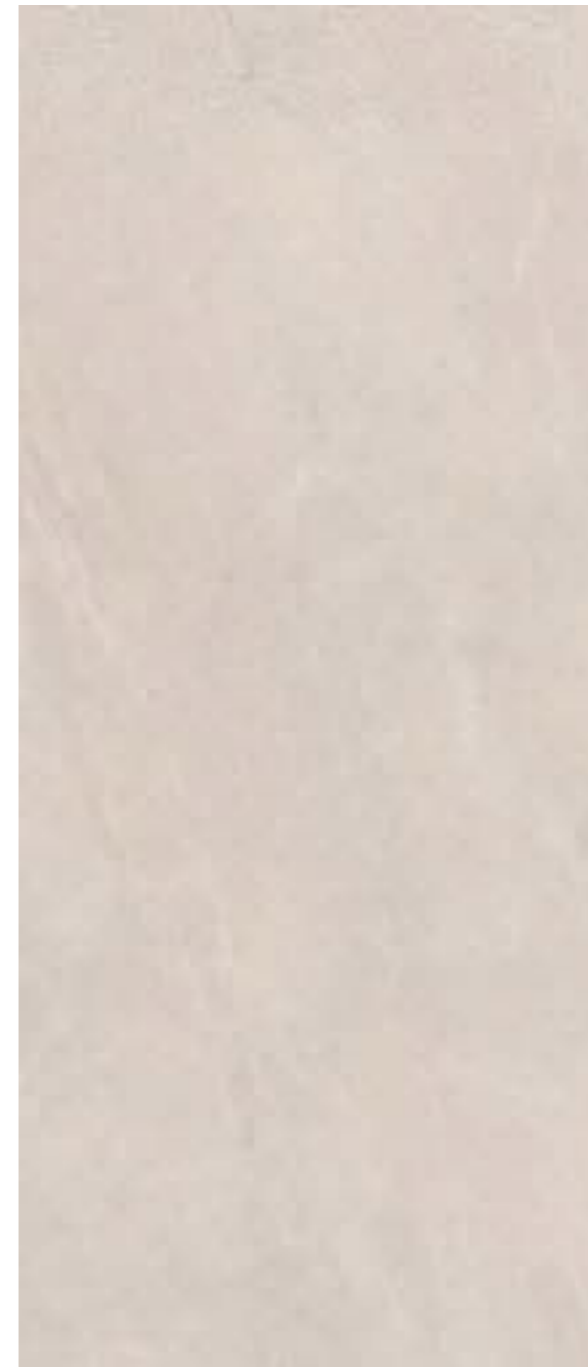

Beige Stripe



Il Decoro Stripe non garantisce continuità di struttura tra un pezzo e l'altro. / The Stripe Decor does not guarantee continuity of the structure between pieces. / Bei dem Dekor Stripe ist die Kontinuität der Linienstruktur zwischen einem Stück und dem nächsten nicht gewährleistet. / Le décor Stripe ne garanti aucune continuité entre une pièce et l'autre.

	6 mm - RealUp	9 mm - RealUp + StrideUp						20 mm - OPEN
	120x280x0,6 cm 47 1/4" x 110 1/4" x 1/4"	80x160 cm 31 1/2" x 63"	120x120 cm 47 1/4" x 47 1/4"	60x120 cm 23 1/2" x 47 1/4"	80x80 cm 31 1/2" x 31 1/2"	60x60 cm 23 1/2" x 23 1/2"	30x60 cm 11 7/8" x 23 1/2"	60x120 cm 23 1/2" x 47 1/4"
RealUp	UGL NL01XPA ■ 110							
RealUp + StrideUp	UGL	NL01GA ■ 078	NL0112 ■ 078	NL01BA ■ 068	NL0188 ■ 062	NL0168 ■ 052	NL0163 ■ 052	
Stripe	UGL			NL01BAS ■ 080				
Antislip	UGL			NL01BAA ■ 068				NL01BA2 ■ 095

	6 mm - RealUp	9 mm - RealUp + StrideUp						20 mm - OPEN
	120x280x0,6 cm 47 1/4" x 110 1/4" x 1/4"	80x160 cm 31 1/2" x 63"	120x120 cm 47 1/4" x 47 1/4"	60x120 cm 23 1/2" x 47 1/4"	80x80 cm 31 1/2" x 31 1/2"	60x60 cm 23 1/2" x 23 1/2"	30x60 cm 11 7/8" x 23 1/2"	60x120 cm 23 1/2" x 47 1/4"
RealUp	UGL NL02XPA ■ 110							
RealUp + StrideUp	UGL	NL02GA ■ 078	NL0212 ■ 078	NL02BA ■ 068	NL0288 ■ 062	NL0268 ■ 052	NL0263 ■ 052	
Stripe	UGL			NL02BAS ■ 080				
Antislip	UGL		NL0212A ■ 078	NL02BAA ■ 068				NL02BA2 ■ 095

# Ivory



# Ivory Stripe



Il Decoro Stripe non garantisce continuità di struttura tra un pezzo e l'altro. / The Stripe Decor does not guarantee continuity of the structure between pieces. / Bei dem Dekor Stripe ist die Kontinuität der Linienstruktur zwischen einem Stück und dem nächsten nicht gewährleistet. / Le décor Stripe ne garanti aucune continuité entre une pièce et l'autre.

# Flax



# Flax Stripe



Il Decoro Stripe non garantisce continuità di struttura tra un pezzo e l'altro. / The Stripe Decor does not guarantee continuity of the structure between pieces. / Bei dem Dekor Stripe ist die Kontinuität der Linienstruktur zwischen einem Stück und dem nächsten nicht gewährleistet. / Le décor Stripe ne garanti aucune continuité entre une pièce et l'autre.

	6 mm - RealUp	9 mm - RealUp + StrideUp					
	120x280x0,6 cm 47 <sup>1/4</sup> "x110 <sup>1/4</sup> "x1/4"	80x160 cm 31 <sup>1/2</sup> "x63"	120x120 cm 47 <sup>1/4</sup> "x47 <sup>1/4</sup> "	60x120 cm 23 <sup>1/2</sup> "x47 <sup>1/4</sup> "	80x80 cm 31 <sup>1/2</sup> "x31 <sup>1/2</sup> "	60x60 cm 23 <sup>1/2</sup> "x23 <sup>1/2</sup> "	30x60 cm 11 <sup>7/8</sup> "x23 <sup>1/2</sup> "
<b>RealUp</b>	UGL NL03XPA ■ 110						
<b>RealUp + StrideUp</b>	UGL	NL03GA ■ 078	NL0312 ■ 078	NL03BA ■ 068	NL0388 ■ 062	NL0368 ■ 052	NL0363 ■ 052
<b>Stripe</b>	UGL	NL03BAS ■ 080					
<b>Antislip</b>	UGL	NL0312A ■ 078 NL03BAA ■ 068					

	6 mm - RealUp	9 mm - RealUp + StrideUp				20 mm - OPEN
	120x280x0,6 cm 47 <sup>1/4</sup> "x110 <sup>1/4</sup> "x1/4"	120x120 cm 47 <sup>1/4</sup> "x47 <sup>1/4</sup> "	60x120 cm 23 <sup>1/2</sup> "x47 <sup>1/4</sup> "	60x60 cm 23 <sup>1/2</sup> "x23 <sup>1/2</sup> "	30x60 cm 11 <sup>7/8</sup> "x23 <sup>1/2</sup> "	60x120 cm 23 <sup>1/2</sup> "x47 <sup>1/4</sup> "
<b>RealUp</b>	UGL NL04XPA ■ 110					
<b>RealUp + StrideUp</b>	UGL	NL0412 ■ 078	NL04BA ■ 068	NL0468 ■ 052	NL0463 ■ 052	
<b>Stripe</b>	UGL	NL04BAS ■ 080				
<b>Antislip</b>	UGL	NL04BAA ■ 068 NL04BA2 ■ 095				

# Greige

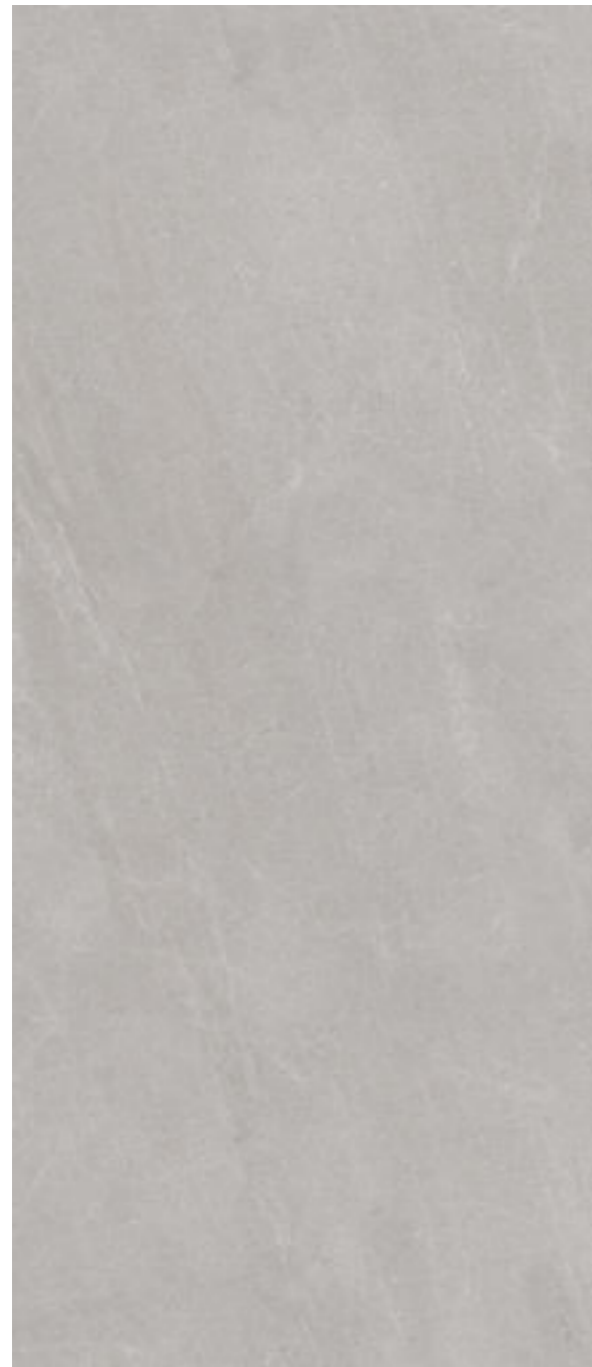

# Greige Stripe

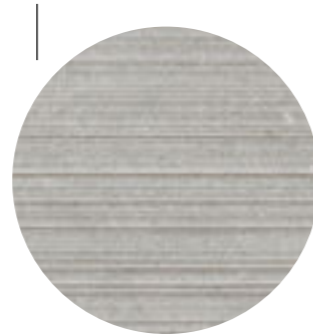

Il Decoro Stripe non garantisce continuità di struttura tra un pezzo e l'altro. / The Stripe Decor does not guarantee continuity of the structure between pieces. / Bei dem Dekor Stripe ist die Kontinuität der Linienstruktur zwischen einem Stück und dem nächsten nicht gewährleistet. / Le décor Stripe ne garanti aucune continuité entre une pièce et l'autre.

# Argil



# Argil Stripe



Il Decoro Stripe non garantisce continuità di struttura tra un pezzo e l'altro. / The Stripe Decor does not guarantee continuity of the structure between pieces. / Bei dem Dekor Stripe ist die Kontinuität der Linienstruktur zwischen einem Stück und dem nächsten nicht gewährleistet. / Le décor Stripe ne garanti aucune continuité entre une pièce et l'autre.

	6 mm - RealUp	9 mm - RealUp + StrideUp				20 mm - OPEN
	120x280x0,6 cm 47 <sup>1/4</sup> "x110 <sup>1/4</sup> "x1/4"	120x120 cm 47 <sup>1/4</sup> "x47 <sup>1/4</sup> "	60x120 cm 23 <sup>1/2</sup> "x47 <sup>1/4</sup> "	60x60 cm 23 <sup>1/2</sup> "x23 <sup>1/2</sup> "	30x60 cm 11 <sup>7/8</sup> "x23 <sup>1/2</sup> "	60x120 cm 23 <sup>1/2</sup> "x47 <sup>1/4</sup> "
<b>RealUp</b>	UGL NL05XPA ■ 110					
<b>RealUp + StrideUp</b>	UGL	NL0512 ■ 078	NL05BA ■ 068	NL0568 ■ 052	NL0563 ■ 052	
<b>Stripe</b>	UGL	NL05BAS ■ 080				
<b>Antislip</b>	UGL	NL05BAA ■ 068				NL05BA2 ■ 095

	6 mm - RealUp	9 mm - RealUp + StrideUp					
	120x280x0,6 cm 47 <sup>1/4</sup> "x110 <sup>1/4</sup> "x1/4"	80x160 cm 31 <sup>1/2</sup> "x63"	120x120 cm 47 <sup>1/4</sup> "x47 <sup>1/4</sup> "	60x120 cm 23 <sup>1/2</sup> "x47 <sup>1/4</sup> "	80x80 cm 31 <sup>1/2</sup> "x31 <sup>1/2</sup> "	60x60 cm 23 <sup>1/2</sup> "x23 <sup>1/2</sup> "	30x60 cm 11 <sup>7/8</sup> "x23 <sup>1/2</sup> "
<b>RealUp</b>	UGL NL06XPA ■ 110						
<b>RealUp + StrideUp</b>	UGL	NL06GA ■ 078	NL0612 ■ 078	NL06BA ■ 068	NL0688 ■ 062	NL0668 ■ 052	NL0663 ■ 052
<b>Stripe</b>	UGL	NL06BAS ■ 080					
<b>Antislip</b>	UGL	NL0612A ■ 078		NL06BAA ■ 068			

Moka



Moka Stripe

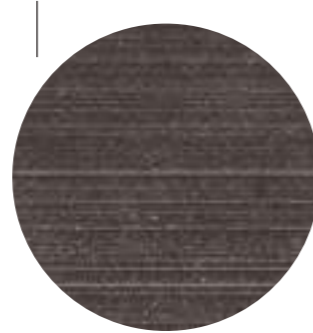

Il Decoro Stripe non garantisce continuità di struttura tra un pezzo e l'altro. / The Stripe Decor does not guarantee continuity of the structure between pieces. / Bei dem Dekor Stripe ist die Kontinuität der Linienstruktur zwischen einem Stück und dem nächsten nicht gewährleistet. / Le décor Stripe ne garanti aucune continuité entre une pièce et l'autre.



Dark



Dark Stripe

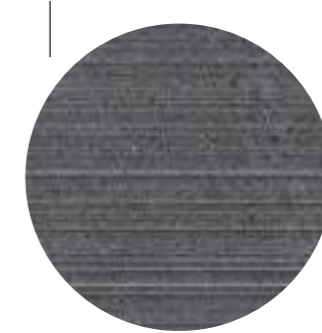

Il Decoro Stripe non garantisce continuità di struttura tra un pezzo e l'altro. / The Stripe Decor does not guarantee continuity of the structure between pieces. / Bei dem Dekor Stripe ist die Kontinuität der Linienstruktur zwischen einem Stück und dem nächsten nicht gewährleistet. / Le décor Stripe ne garanti aucune continuité entre une pièce et l'autre.

	6 mm - RealUp	9 mm - RealUp + StrideUp			
	120x280x0,6 cm 47 <sup>11/16</sup> x 110 <sup>11/16</sup> x 1/4"	120x120 cm 47 <sup>11/16</sup> x 47 <sup>11/16</sup>	60x120 cm 23 <sup>1/2</sup> x 47 <sup>11/16</sup>	60x60 cm 23 <sup>1/2</sup> x 23 <sup>1/2</sup>	30x60 cm 11 <sup>7/8</sup> x 23 <sup>1/2</sup>
RealUp	UGL NL08XPA ■ 110				
RealUp + StrideUp	UGL	NL0812 ■ 078	NL08BA ■ 068	NL0868 ■ 052	NL0863 ■ 052
Stripe	UGL	NL08BAS ■ 080			

	6 mm - RealUp	9 mm - RealUp + StrideUp			
	120x280x0,6 cm 47 <sup>11/16</sup> x 110 <sup>11/16</sup> x 1/4"	120x120 cm 47 <sup>11/16</sup> x 47 <sup>11/16</sup>	60x120 cm 23 <sup>1/2</sup> x 47 <sup>11/16</sup>	60x60 cm 23 <sup>1/2</sup> x 23 <sup>1/2</sup>	30x60 cm 11 <sup>7/8</sup> x 23 <sup>1/2</sup>
RealUp	UGL NL07XPA ■ 110				
RealUp + StrideUp	UGL	NL0712 ■ 078	NL07BA ■ 068	NL0768 ■ 052	NL0763 ■ 052
Stripe	UGL	NL07BAS ■ 080			

### Mosaico

30x30

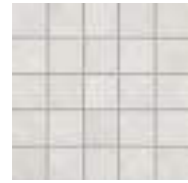

White  
9 mm



Beige  
9 mm



Ivory  
9 mm



Flax  
9 mm



Greige  
9 mm

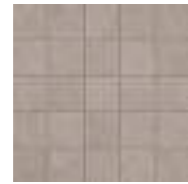

Argil  
9 mm



Moka  
9 mm



Dark  
9 mm

### Muretto

30x30



White  
6 mm / 9 mm



Beige  
6 mm / 9 mm



Ivory  
6 mm / 9 mm



Flax  
6 mm / 9 mm



Greige  
9 mm



Argil  
9 mm



Moka  
9 mm



Dark  
9 mm

### Listello Tratto

20x120



White  
6 mm



Beige  
6 mm



Ivory  
6 mm



Flax  
6 mm



Greige  
6 mm



Argil  
6 mm



Moka  
6 mm



Dark  
6 mm



Su rete / Mesh mounted



Tessera  
2,5x120 1"x47 1/4"

Listello Tratto



Tessera  
2,8x9,8 1 1/8"x3 7/8"

Muretto



Tessera  
5x5 2"x2"

Mosaico

#### 6 mm - RealUp - UGL



Listello Tratto  
20x120 cm  
8"x47 1/4"  
(Pcs Box 6)



Muretto  
30x30 cm  
11 7/8"x11 7/8"  
(Pcs Box 6)

#### 9 mm - RealUp + StrideUp - UGL



Muretto  
30x30 cm  
11 7/8"x11 7/8"  
(Pcs Box 6)



Mosaico  
30x30 cm  
11 7/8"x11 7/8"  
(Pcs Box 12)

<b>WHITE</b>	NL01LT 098	NL01MB 043	NL01MB9 027	NL013MA 137
<b>BEIGE</b>	NL02LT 098	NL02MB 043	NL02MB9 027	NL023MA 137
<b>IVORY</b>	NL03LT 098	NL03MB 043	NL03MB9 027	NL033MA 137
<b>FLAX</b>	NL04LT 098	NL04MB 043	NL04MB9 027	NL043MA 137
<b>GREIGE</b>	NL05LT 098	NL05MB 043	NL05MB9 027	NL053MA 137
<b>ARGIL</b>	NL06LT 098	NL06MB 043	NL06MB9 027	NL063MA 137
<b>MOKA</b>	NL08LT 098	NL08MB 043	NL08MB9 027	NL083MA 137
<b>DARK</b>	NL07LT 098	NL07MB 043	NL07MB9 027	NL073MA 137

Pezzi speciali / Special pieces

9 mm



Color	RealUp + StrideUp	Antislip	RealUp + StrideUp	Antislip	RealUp + StrideUp	Antislip
WHITE	NL0176 ■ 009	NL01BT7 ■ 018	NL01GT2 ■ 223	NL0195I ■ 059		
BEIGE	NL0276 ■ 009	NL02BT7 ■ 018	NL02GT2 ■ 223	NL0295I ■ 059	NL02EL120 ■ 143	
IVORY	NL0376 ■ 009	NL03BT7 ■ 018	NL03GT2 ■ 223	NL0395I ■ 059	NL03EL120 ■ 143	
FLAX	NL0476 ■ 009	NL04BT7 ■ 018	NL04GT2 ■ 223	NL0495I ■ 059		
GREIGE	NL0576 ■ 009	NL05BT7 ■ 018	NL05GT2 ■ 223	NL0595I ■ 059		
ARGIL	NL0676 ■ 009	NL06BT7 ■ 018	NL06GT2 ■ 223	NL0695I ■ 059	NL06EL120 ■ 143	
MOKA	NL0876 ■ 009	NL08BT7 ■ 018	NL08GT2 ■ 223			
DARK	NL0776 ■ 009	NL07BT7 ■ 018	NL07GT2 ■ 223			



20 mm Open - Pezzi speciali / Special pieces

Per approfondimenti sui pezzi speciali e tutti gli accessori per esterno 20mm scarica la scheda tecnica oppure consultare il nostro sito e il catalogo Open.

For further information on special pieces and all 20mm outdoor accessories download the technical data sheet or consult our website and the Open catalog.

Für weitere Informationen zu Sonderteilen und dem gesamten 20mm Outdoor-Zubehör laden Sie das technische Datenblatt herunter oder besuchen Sie unsere Website und den Open Katalog.

Pour approfondissements sur les pièces de finition et accessoires pour extérieurs en 20mm, merci de télécharger la fiche technique ou bien consulter notre site web et le catalogue OPEN.

Download Catalogue



Argil 60x120, Argil Muretto 30x30, Moka 120x120

Imballi / Packing

Tile Size	Thickness	Finish	PCS / BOX	M² / BOX	KG / BOX	BOX / PALLET	M² / PALLET	KG / PALLET
120x120 cm - 47 <sup>1/4</sup> "x47 <sup>1/4</sup> "	Thick 9 mm	RealUp + StrideUp	PZ / PCS 2	M² 2,88	KG 58,01	PZ / PCS 18	M² 51,84	KG 1.064,32
120x120 cm - 47 <sup>1/4</sup> "x47 <sup>1/4</sup> "	Thick 9 mm	Antislip	PZ / PCS 02	M² 2,88	KG 59,49	PZ / PCS 18	M² 51,84	KG 1.090,85
80x160 cm - 31 <sup>1/2</sup> "x62 <sup>7/8</sup> "	Thick 9 mm	RealUp	PZ / PCS 02	M² 2,56	KG 49,93	PZ / PCS 18	M² 46,08	KG 900,77
60x120 cm - 23 <sup>1/2</sup> "x47 <sup>1/4</sup> "	Thick 9 mm	RealUp + StrideUp Stripe	PZ / PCS 2	M² 1,44	KG 28,54	PZ / PCS 36	M² 51,84	KG 1.047,58
60x120 cm - 23 <sup>1/2</sup> "x47 <sup>1/4</sup> "	Thick 9 mm	Antislip	PZ / PCS 2	M² 1,44	KG 28,86	PZ / PCS 36	M² 51,84	KG 987,24
OPEN 60x120 cm - 23 <sup>1/2</sup> "x47 <sup>1/4</sup> "	Thick 20 mm	Antislip	PZ / PCS 1	M² 0,72	KG 31,65	PZ / PCS 36	M² 25,92	KG 1.159,58
80x80 cm - 31 <sup>1/2</sup> "x31 <sup>1/2</sup> "	Thick 9 mm	RealUp + StrideUp	PZ / PCS 2	M² 1,28	KG 25,32	PZ / PCS 42	M² 53,76	KG 1.083,60
60x60 cm - 23 <sup>1/2</sup> "x23 <sup>1/2</sup> "	Thick 9 mm	RealUp + StrideUp	PZ / PCS 4	M² 1,44	KG 27,40	PZ / PCS 30	M² 43,20	KG 842,09
30x60 cm - 11 <sup>7/8</sup> "x23 <sup>1/2</sup> "	Thick 9 mm	RealUp + StrideUp	PZ / PCS 8	M² 1,44	KG 27,59	PZ / PCS 32	M² 46,08	KG 902,88
Listello Tratto 20x120 cm - 8"x47 <sup>1/4</sup> "	Thick 6 mm	RealUp	PZ / PCS 6	M² 1,44	KG 19,02	PZ / PCS 30	M² 43,20	KG 590,60
Muretto 30x30 cm - 11 <sup>7/8</sup> "x11 <sup>7/8</sup> "	Thick 9 mm	RealUp + StrideUp	PZ / PCS 6	M² 0,54	KG 10,45	PZ / PCS 60	M² 32,40	KG 647,48
Muretto 30x30 cm - 11 <sup>7/8</sup> "x11 <sup>7/8</sup> "	Thick 6 mm	RealUp	PZ / PCS 6	M² 0,54	KG 7,20	PZ / PCS 60	M² 32,04	KG 452,00
Mosaico 30x30 cm - 11 <sup>7/8</sup> "x11 <sup>7/8</sup> "	Thick 9 mm	RealUp + StrideUp	PZ / PCS 12	M² 1,08	KG 20,62	PZ / PCS 30	M² 32,40	KG 638,60

Imballi Mega / Mega Packing

Tile Size	DESCRIPTION IMBALLO / PACKAGING DESCRIPTION	MQ / KG / LASTRA / SLAB	IMBALLO PIENO / FULL PACKAGING	IMBALLO VUOTO / EMPTY PACKAGING
120x280x0,6 cm - 47 <sup>1/4</sup> "x110 <sup>1/4</sup> "x1/4"	CASSA / CRATE L 145 x P 292 x H 35	MQ 3,36	MQ 67,20	
		KG 48,60	KG 1062,00	KG 100,00
120x280x0,6 cm - 47 <sup>1/4</sup> "x110 <sup>1/4</sup> "x1/4"	CAVALLETTO / A-FRAME L 75 x P 285 x H 153	MQ 3,36	MQ 147,84	
		KG 48,60	KG 2318,40	KG 180,00
120x280x0,6 cm - 47 <sup>1/4</sup> "x110 <sup>1/4</sup> "x1/4"	CASSA LIGHT / LIGHT CRATE L 145 x P 292 x H 27	MQ 3,36	MQ 30,24	
		KG 48,60	KG 527,40	KG 90,00
			PZ 1 / 9	

Stucchi consigliati / Recommended grouts

Colori / Colors	White	Beige	Ivory	Flax	Greige	Argil	Moka	Dark
Kerakoll	KK66	KK64	KK79	KK66	KK68	KK81	KK158	KK10
Mapei	60% 100 + 40% 110	111	80% 111 + 20% 132	80% 110 + 20% 112	80% 110 + 20% 112	50% 110 + 50% 134	30% 100 + 70% 114	40% 100 + 60% 119

Le tipologie di stucchi riportate nella tabella sono semplici suggerimenti. Prima della posa si raccomanda di eseguire un test di stuccatura per verificarne la compatibilità con la superficie ceramica e le condizioni di utilizzo. / The types of grout listed in the table are simply suggestions. Before installation, it is recommended to perform a grouting test to verify compatibility with the ceramic surface and conditions of use. / Die in der Tabelle aufgeführten Fugenmörteltypen sind lediglich Empfehlungen. Vor dem Verlegen wird empfohlen, einen Fugentest durchzuführen, um die Verträglichkeit mit der Keramikoberfläche und den Einsatzbedingungen zu überprüfen. / Les types de mastics indiqués dans le tableau sont de simples suggestions. Avant la pose, il est recommandé d'effectuer un test de masticage afin de vérifier la compatibilité avec la surface céramique et les conditions d'utilisation.



# Dorset

Gres porcellanato - Rettificato / Porcelain Stoneware - Rectified  
Feinsteinzeug - Kalibriert / Gres Cerame - Rectifié

New Innovative  
Technology



Download  
Catalogue

Conforming to Standards  
EN 14411 ISO 13006 APPENDICE G GRUPPO BIa UGL CON  $E_v \leq 0,5\%$

RealUp®  
StrideUp®

Caratteristiche tecniche  
Technical features

BENDING STRENGTH	FROST RESISTANCE	CHEMICAL RESISTANCE	STAIN RESISTANCE	
ANSI A326.3 > 0,42	R10 / A+B	R11 / A+B+C	TRAFFICO INTENSO HEAVY TRAFFIC	V2 MODERATE
Naturale / Matte RealUp + StrideUp Antislip OPEN	RealUp + StrideUp	Antislip OPEN	Naturale / Matte RealUp + StrideUp Antislip OPEN	All Colours

Formati  
Sizes

	6 mm	9 mm	20 mm - OPEN						
<b>SUPERFICIE SURFACE</b>	120x280x0,6 cm 47 <sup>1/4</sup> "x110 <sup>1/4</sup> "x1/4"	120x120 cm 47 <sup>1/4</sup> "x47 <sup>1/4</sup> "	60x120 cm 23 <sup>1/2</sup> "x47 <sup>1/4</sup> "	80x80 cm 31 <sup>1/2</sup> "x31 <sup>1/2</sup> "	60x60 cm 23 <sup>1/2</sup> "x23 <sup>1/2</sup> "	30x60 cm 11 <sup>7/8</sup> "x23 <sup>1/2</sup> "	Not rectified 30x60 cm 11 <sup>7/8</sup> "x23 <sup>1/2</sup> "	60x120 cm 23 <sup>1/2</sup> "x47 <sup>1/4</sup> "	60x60 cm 23 <sup>1/2</sup> "x23 <sup>1/2</sup> "
Naturale / Matte	■								
RealUp + StrideUp		■	■	■	■	■			
Ribbed			■						
Antislip		■ <small>(new)</small>	■				■	■	■

Colori  
Colours

Bianco Cross Cut	Bianco Vein Cut	Beige Cross Cut	Beige Vein Cut	Tortora Cross Cut	Tortora Vein Cut	Cenere Cross Cut	Cenere Vein Cut

Superficie  
Surface finishes

Naturale Matte	RealUp + StrideUp	Ribbed	Antislip

Bianco Vein Cut 60x120, Nuances Giada 120x280x0,6



Cenere 120x280x0,6, Cenere 120x120, Nuances Giada 120x280x0,6, Listello Tratto Giada 20x120x0,6



Bianco 120x280x0,6, Bianco 120x120, Bianco Ribbed 60x120, Nuances Muretto Giada 30x30, Loom Piano 180



Tortora 120x280x0,6, Tortora 120x120, Nuances Luce 120x280x0,6

### Bianco Cross Cut



### Bianco Vein Cut



### Bianco Cross Cut Ribbed



Il Decoro Ribbed non garantisce continuità di struttura tra un pezzo e l'altro. / The Ribbed Decor does not guarantee continuity of the structure between pieces. / Bei dem Dekor Ribbed ist die Kontinuität der Linienstruktur zwischen einem Stück und dem nächsten nicht gewährleistet. / Le décor Ribbed ne garanti aucune continuité entre une pièce et l'autre.

### Beige Cross Cut



### Beige Vein Cut



### Beige Cross Cut Ribbed

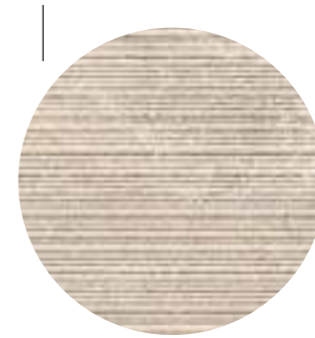

Il Decoro Ribbed non garantisce continuità di struttura tra un pezzo e l'altro. / The Ribbed Decor does not guarantee continuity of the structure between pieces. / Bei dem Dekor Ribbed ist die Kontinuität der Linienstruktur zwischen einem Stück und dem nächsten nicht gewährleistet. / Le décor Ribbed ne garanti aucune continuité entre une pièce et l'autre.

		6 mm	9 mm - RealUp + StrideUp					20 mm - OPEN	
		120x280x0,6 cm 47 1/4" x 110 1/8" x 1/4"	120x120 cm 47 1/8" x 47 1/8"	60x120 cm 23 1/2" x 47 1/8"	80x80 cm 31 1/2" x 31 1/2"	60x60 cm 23 1/2" x 23 1/2"	30x60 cm 11 7/8" x 23 1/2"	30x60 cm 11 7/8" x 23 1/2"	60x120 cm 23 1/2" x 47 1/8"
Naturale / Matte	UGL BIANCO CROSS CUT	DR01XPA ■ 110							
RealUp + StrideUp	UGL BIANCO CROSS CUT		DR0112 ■ 078	DR01BA ■ 068	DR0188 ■ 062	DR0168 ■ 052	DR0163 ■ 052		
	UGL BIANCO VEIN CUT			DR02BA ■ 068		DR0263 ■ 052			
Ribbed	UGL BIANCO CROSS CUT			DR01BAR ■ 080					
Antislip	UGL BIANCO CROSS CUT		DR0112A ■ 078	DR01BAA ■ 068			DR0160A ■ 037	DR01BA2 ■ 095	

		6 mm	9 mm - RealUp + StrideUp					20 mm - OPEN		
		120x280x0,6 cm 47 1/4" x 110 1/8" x 1/4"	120x120 cm 47 1/8" x 47 1/8"	60x120 cm 23 1/2" x 47 1/8"	80x80 cm 31 1/2" x 31 1/2"	60x60 cm 23 1/2" x 23 1/2"	30x60 cm 11 7/8" x 23 1/2"	30x60 cm 11 7/8" x 23 1/2"	60x120 cm 23 1/2" x 47 1/8"	60x60 cm 23 1/2" x 23 1/2"
Naturale / Matte	UGL BEIGE CROSS CUT	DR03XPA ■ 110								
RealUp + StrideUp	UGL BEIGE CROSS CUT		DR0312 ■ 078	DR03BA ■ 068	DR0388 ■ 062	DR0368 ■ 052	DR0363 ■ 052			
	UGL BEIGE VEIN CUT			DR04BA ■ 068		DR0463 ■ 052				
Ribbed	UGL BEIGE CROSS CUT			DR03BAR ■ 080						
Antislip	UGL BEIGE CROSS CUT		DR0312A ■ 078	DR03BAA ■ 068			DR0360A ■ 037	DR03BA2 ■ 095	DR03682 ■ 075	

### Tortora Cross Cut



### Tortora Vein Cut



### Tortora Cross Cut Ribbed

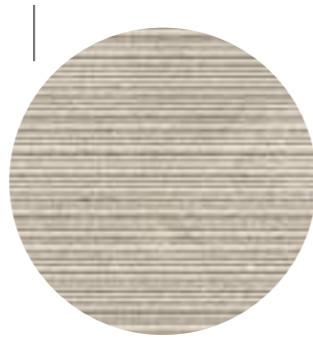

Il Decoro Ribbed non garantisce continuità di struttura tra un pezzo e l'altro. / The Ribbed Decor does not guarantee continuity of the structure between pieces. / Bei dem Dekor Ribbed ist die Kontinuität der Linienstruktur zwischen einem Stück und dem nächsten nicht gewährleistet. / Le décor Ribbed ne garanti aucune continuité entre une pièce et l'autre.

### Cenere Cross Cut



### Cenere Vein Cut



### Cenere Cross Cut Ribbed

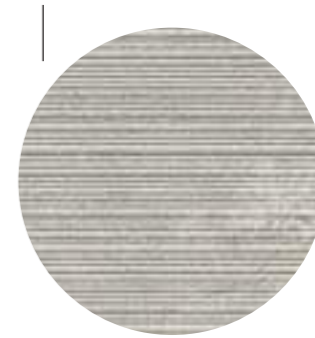

Il Decoro Ribbed non garantisce continuità di struttura tra un pezzo e l'altro. / The Ribbed Decor does not guarantee continuity of the structure between pieces. / Bei dem Dekor Ribbed ist die Kontinuität der Linienstruktur zwischen einem Stück und dem nächsten nicht gewährleistet. / Le décor Ribbed ne garanti aucune continuité entre une pièce et l'autre.

		6 mm	9 mm - RealUp + StrideUp						Not rectified	
		120x280x0,6 cm 47 1/4" x 110 1/4" x 1/4"	120x120 cm 47 1/4" x 47 1/4"	60x120 cm 23 1/2" x 47 1/4"	80x80 cm 31 1/2" x 31 1/2"	60x60 cm 23 1/2" x 23 1/2"	30x60 cm 11 7/8" x 23 1/2"	30x60 cm 11 7/8" x 23 1/2"		
Naturale / Matte	UGL TORTORA CROSS CUT	DR05XPA ■ 110								
RealUp + StrideUp	UGL TORTORA CROSS CUT		DR0512 ■ 078	DR05BA ■ 068	DR0588 ■ 062	DR0568 ■ 052	DR0563 ■ 052			
	UGL TORTORA VEIN CUT		DR06BA ■ 068		DR0663 ■ 052					
Ribbed	UGL TORTORA CROSS CUT		DR05BAR ■ 080							
Antislip	UGL TORTORA CROSS CUT		DR05BAA ■ 068				DR0560A ■ 037			

		6 mm	9 mm - RealUp + StrideUp						20 mm - OPEN	
		120x280x0,6 cm 47 1/4" x 110 1/4" x 1/4"	120x120 cm 47 1/4" x 47 1/4"	60x120 cm 23 1/2" x 47 1/4"	80x80 cm 31 1/2" x 31 1/2"	60x60 cm 23 1/2" x 23 1/2"	30x60 cm 11 7/8" x 23 1/2"	30x60 cm 11 7/8" x 23 1/2"	60x120 cm 23 1/2" x 47 1/4"	60x60 cm 23 1/2" x 23 1/2"
Naturale / Matte	UGL CENERE CROSS CUT	DR07XPA ■ 110								
RealUp + StrideUp	UGL CENERE CROSS CUT		DR0712 ■ 078	DR07BA ■ 068	DR0788 ■ 062	DR0768 ■ 052	DR0763 ■ 052			
	UGL CENERE VEIN CUT		DR08BA ■ 068		DR0863 ■ 052					
Ribbed	UGL CENERE CROSS CUT		DR07BAR ■ 080							
Antislip	UGL CENERE CROSS CUT		DR07BAA ■ 068				DR0760A ■ 037		DR07BA2 ■ 095	DR07682 ■ 075

# Decoro Rilievo 3D

Design Andrea Parisio & Giuseppe Pezzano



**Bianco Vein Cut**  
20x120 - 20x120 inciso sul retro  
40x120 - 40x120 inciso sul retro

**Bianco Vein Cut**  
60x120



**Beige Vein Cut**  
20x120 - 20x120 inciso sul retro  
40x120 - 40x120 inciso sul retro

**Beige Vein Cut**  
60x120



**Tortora Vein Cut**  
20x120 - 20x120 inciso sul retro  
40x120 - 40x120 inciso sul retro

**Tortora Vein Cut**  
60x120

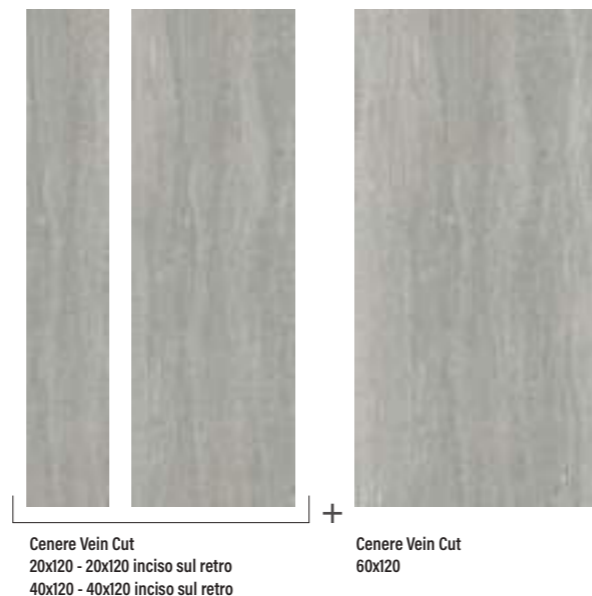

**Cenere Vein Cut**  
20x120 - 20x120 inciso sul retro  
40x120 - 40x120 inciso sul retro

**Cenere Vein Cut**  
60x120

■ 9 mm  
RealUp + StrideUp - UGL



Decoro Rilievo 3D  
120x120  
(20x120 2pz - 40x120 2pz)  
(8"x47 1/4" 2pcs - 15 3/4"x47 1/4" 2pcs)  
(Pcs Box 4)

<b>BIANCO VEIN CUT</b>	DR02DRL ■ 324
<b>BEIGE VEIN CUT</b>	DR04DRL ■ 324
<b>TORTORA VEIN CUT</b>	DR06DRL ■ 324
<b>CENERE VEIN CUT</b>	DR08DRL ■ 324

Le scatole dei listelli sono così composte / The listels boxes are composed as follows  
Jeder Karton besteht aus den folgenden Produkten / Les boîtes des listels sont composées par :  
- 1 pezzo 20x120  
- 1 pezzo 20x120 inciso sul retro / engraved on the back / auf der Rückseite eingepägt / gravé au dos  
- 1 pezzo 40x120  
- 1 pezzo 40x120 inciso sul retro / engraved on the back / auf der Rückseite eingepägt / gravé au dos

## Schemi di posa a 3 formati / installation systems with 3 sizes

Per garantire un progetto di posa a regola d'arte, consigliamo uno schema random alternando - ai formati 20x120 e 40x120 - il fondo 60x120 cm.

To ensure a proper installation, we recommend a random pattern by alternating the 20x120cm (8"x48") and 40x120cm (32"x48") sizes with the 60x120cm (24"x48") field tile.

Um ein fachgerechtes Verlegebild zu gewährleisten, empfehlen wir ein zufälliges Schema, bei dem sich die Formate 20x120 und 40x120 mit den 60x120 Grundfliesen abwechseln.

Pour assurer u projet réalisé dans la règle de l'art, nous préconisons un schéma aléatoire en alternant aux formats 20x120 et 40x120 l'uni en 60x120.

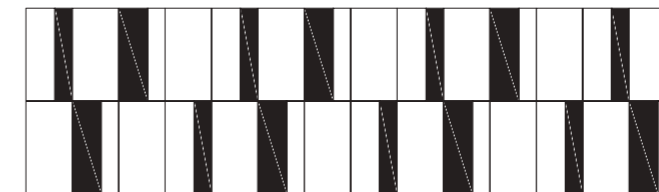

SIZES	20x120	60x120
	20x120 inciso sul retro / engraved on the back	
	40x120	
	40x120 inciso sul retro / engraved on the back	
% MQ	50%	50%

Nello schema accanto i formati incisi sul retro sono indicati dal colore nero.  
In the pattern beside, the sizes engraved on the back are indicated by the color black.  
In der nebenstehenden Abbildung sind die auf der Rückseite eingepägten Formate durch die Farbe Schwarz gekennzeichnet.  
Dans le tableau ici à côté, les formats gravés sur le dos sont indiqués en noir.

## Decoro Rilievo 3D

Design Andrea Parisio & Giuseppe Pezzano

Nell'immaginare questo decoro gli architetti Andrea Parisio e Giuseppe Pezzano si sono ispirati alla plasticità dei rivestimenti lapidei che caratterizzano l'architettura dei palazzi italiani. Rilievo 3D è un decoro che abbina un listello posato in modo planare ad un listello il cui lato maggiore viene posato in sovrapposizione, creando un modulo dall'originale effetto di tridimensionalità. Ciò è possibile grazie all'incisione effettuata sul retro, che in fase di installazione genera l'effetto 3D.

In imagining this decoration, the architects Andrea Parisio and Giuseppe Pezzano were inspired by the plasticity of the wall stone that characterize the architecture of Italian

buildings. The decoration combines a listel laid flatly with a listel which longer side is installed overlapping. This creates a module with an original three-dimensional effect. The overlapping is possible thanks to the engraving made on the back of the strip, which generates the 3D effect.

Bei der Realisierung dieses Dekors ließen sich die Architekten Andrea Parisio und Giuseppe Pezzano von der Plastizität der für italienische Gebäude typischen Natursteinverkleidungen inspirieren. Die Dekoration kombiniert einen planar verlegten Riemen mit einem weiteren Riemen, dessen längere Seite überlappend verlegt wird. So entsteht ein Modul mit

einer originellen dreidimensionalen Optik. Die Überlappung ist dank der Gravur auf der Rückseite des Riemens möglich, die bei der Verlegung die 3D-Optik erzeugt.

En imaginant cette décoration, les architectes Andrea Parisio et Giuseppe Pezzano se sont inspirés de la plasticité des revêtements en pierre caractéristiques de l'architecture des palais italiens. La décoration associe un listel posé à plat à un listel dont le grand côté est posé en superposition afin de créer un module offrant un effet tridimensionnel original. La superposition est possible grâce à l'incision effectuée à l'arrière du listel qui, lors de l'installation, génère l'effet 3D.

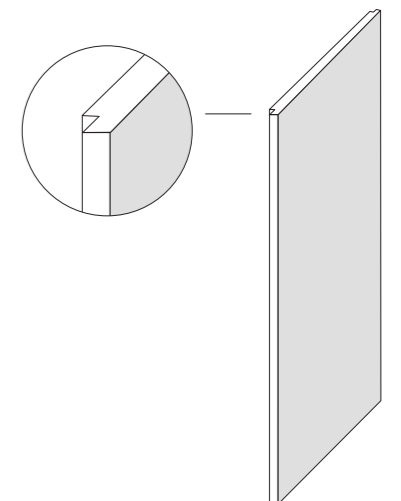

### Listello Tratto Cross Cut

20x120



Bianco Cross Cut  
6 mm



Beige Cross Cut  
6 mm



Tortora Cross Cut  
6 mm



Cenere Cross Cut  
6 mm

### Muretto Cross Cut

30x30



Bianco Cross Cut  
6 mm / 9 mm



Beige Cross Cut  
6 mm / 9 mm



Tortora Cross Cut  
6 mm / 9 mm



Cenere Cross Cut  
6 mm / 9 mm

### Muretto Vein Cut

30x30

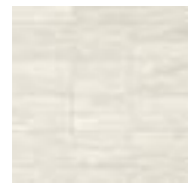

Bianco Vein Cut  
9 mm



Beige Vein Cut  
9 mm



Tortora Vein Cut  
9 mm



Cenere Vein Cut  
9 mm

### Mosaico Cross Cut

30x30



Bianco Cross Cut  
9 mm



Beige Cross Cut  
9 mm



Tortora Cross Cut  
9 mm



Cenere Cross Cut  
9 mm

### Mosaico Vein Cut

30x30



Bianco Vein Cut  
9 mm



Beige Vein Cut  
9 mm



Tortora Vein Cut  
9 mm



Cenere Vein Cut  
9 mm



Su rete / Mesh mounted



Tessera  
2,5x120 1"x47 1/4"



Tessera  
2,8x9,8 1 1/8"x3 7/8"



Tessera  
5x5 2"x2"

#### 6 mm - Naturale / Matte - UGL



Listello Tratto  
20x120 cm  
8"x47 1/4"  
(Pcs Box 6)



Muretto  
30x30 cm  
11 7/8"x11 7/8"  
(Pcs Box 6)

#### 9 mm - RealUp + StrideUp - UGL



Muretto  
30x30 cm  
11 7/8"x11 7/8"  
(Pcs Box 6)



Mosaico  
30x30 cm  
11 7/8"x11 7/8"  
(Pcs Box 12)

<b>BIANCO CROSS CUT</b>	DR01LT 098	DR01MB 043	DR01MB9 027	DR013MA 137
<b>BIANCO VEIN CUT</b>			DR02MB9 027	DR023MA 137
<b>BEIGE CROSS CUT</b>	DR03LT 098	DR03MB 043	DR03MB9 027	DR033MA 137
<b>BEIGE VEIN CUT</b>			DR04MB9 027	DR043MA 137
<b>TORTORA CROSS CUT</b>	DR05LT 098	DR05MB 043	DR05MB9 027	DR053MA 137
<b>TORTORA VEIN CUT</b>			DR06MB9 027	DR063MA 137
<b>CENERE CROSS CUT</b>	DR07LT 098	DR07MB 043	DR07MB9 027	DR073MA 137
<b>CENERE VEIN CUT</b>			DR08MB9 027	DR083MA 137

Pezzi speciali / Special pieces

9 mm



BIANCO CROSS CUT	RealUp + StrideUp	DR0176 ■ 009	DR01GT2 ■ 223
	Antislip	DR01B77 ■ 018	DR0195I ■ 059 DR01EL120 ■ 143
BIANCO VEIN CUT	RealUp + StrideUp	DR0276 ■ 009	DR02GT2 ■ 223
	RealUp + StrideUp	DR0376 ■ 009	DR03GT2 ■ 223
BEIGE CROSS CUT	RealUp + StrideUp	DR0476 ■ 009	DR04GT2 ■ 223
	Antislip	DR03B77 ■ 018	DR0395I ■ 059 DR02EL120 ■ 143
BEIGE VEIN CUT	RealUp + StrideUp	DR0576 ■ 009	DR05GT2 ■ 223
	RealUp + StrideUp	DR0676 ■ 009	DR06GT2 ■ 223
TORTORA CROSS CUT	RealUp + StrideUp	DR0776 ■ 009	DR07GT2 ■ 223
	Antislip	DR07B77 ■ 018	DR0795I ■ 059
TORTORA VEIN CUT	RealUp + StrideUp	DR0876 ■ 009	DR08GT2 ■ 223
	RealUp + StrideUp	DR0976 ■ 009	DR09GT2 ■ 223
CENERE CROSS CUT	RealUp + StrideUp	DR1076 ■ 009	DR10GT2 ■ 223
	Antislip	DR10B77 ■ 018	DR1095I ■ 059
CENERE VEIN CUT	RealUp + StrideUp	DR1176 ■ 009	DR11GT2 ■ 223
	RealUp + StrideUp	DR1276 ■ 009	DR12GT2 ■ 223



Download Catalogue

20 mm Open - Pezzi speciali / Special pieces

Per approfondimenti sui pezzi speciali e tutti gli accessori per esterno 20mm scarica la scheda tecnica oppure consultare il nostro sito e il catalogo Open.

For further information on special pieces and all 20mm outdoor accessories download the technical data sheet or consult our website and the Open catalog.

Für weitere Informationen zu Sonderteilen und dem gesamten 20mm Outdoor Zubehör laden Sie das technische Datenblatt herunter oder besuchen Sie unsere Website und den Open-Katalog.

Pour approfondissements sur les pièces de finition et accessoires pour extérieurs en 20mm, merci de télécharger la fiche technique ou bien consulter notre site web et le catalogue OPEN.



Beige 60x120 20 mm, Nuances Mosaico Giada 30x30

PCS / BOX	M <sup>2</sup> / BOX	KG / BOX	BOX / PALLET	M <sup>2</sup> / PALLET	KG / PALLET
-----------	----------------------	----------	--------------	-------------------------	-------------

Imballi / Packing

DESCRIPTION	THICKNESS	FINISH	PCS / BOX	M <sup>2</sup> / BOX	KG / BOX	BOX / PALLET	M <sup>2</sup> / PALLET	KG / PALLET
120x120 cm - 47 <sup>1/4</sup> "x47 <sup>1/4</sup> "	Thick 9 mm	RealUp + StrideUp	PZ / PCS 2	M <sup>2</sup> 2,88	KG 58,95	PZ / PCS 18	M <sup>2</sup> 51,84	KG 1.081,17
60x120 cm - 23 <sup>1/2</sup> "x47 <sup>1/4</sup> "	Thick 9 mm	RealUp + StrideUp Ribbed	PZ / PCS 2	M <sup>2</sup> 1,44	KG 28,90	PZ / PCS 36	M <sup>2</sup> 51,84	KG 1.060,72
60x120 cm - 23 <sup>1/2</sup> "x47 <sup>1/4</sup> "	Thick 9 mm	Antislip	PZ / PCS 2	M <sup>2</sup> 1,44	KG 29,14	PZ / PCS 36	M <sup>2</sup> 51,84	KG 1.069,25
OPEN 60x120 cm - 23 <sup>1/2</sup> "x47 <sup>1/4</sup> "	Thick 20 mm	Antislip	PZ / PCS 1	M <sup>2</sup> 0,72	KG 32,39	PZ / PCS 36	M <sup>2</sup> 25,92	KG 1.168,68
80x80 cm - 31 <sup>1/2</sup> "x31 <sup>1/2</sup> "	Thick 9 mm	RealUp + StrideUp	PZ / PCS 2	M <sup>2</sup> 1,28	KG 25,32	PZ / PCS 40	M <sup>2</sup> 51,20	KG 1.083,60
60x60 cm - 23 <sup>1/2</sup> "x23 <sup>1/2</sup> "	Thick 9 mm	RealUp + StrideUp	PZ / PCS 4	M <sup>2</sup> 1,44	KG 27,49	PZ / PCS 30	M <sup>2</sup> 43,20	KG 844,85
OPEN 60x60 cm - 23 <sup>1/2</sup> "x23 <sup>1/2</sup> "	Thick 20 mm	Antislip	PZ / PCS 2	M <sup>2</sup> 0,72	KG 32,09	PZ / PCS 30	M <sup>2</sup> 21,60	KG 982,94
30x60 cm - 11 <sup>7/8</sup> "x23 <sup>1/2</sup> "	Thick 9 mm	Antislip	PZ / PCS 8	M <sup>2</sup> 1,44	KG 27,67	PZ / PCS 32	M <sup>2</sup> 46,08	KG 905,50
Not Rectified 30x60 cm - 11 <sup>7/8</sup> "x23 <sup>1/2</sup> "	Thick 9 mm	Antislip	PZ / PCS 8	M <sup>2</sup> 1,44	KG 26,70	PZ / PCS 32	M <sup>2</sup> 46,08	KG 874,40
Listello Tratto 20x120 cm - 8"x47 <sup>1/4</sup> "	Thick 6 mm	RealUp + StrideUp	PZ / PCS 6	M <sup>2</sup> 1,44	KG 19,42	PZ / PCS 30	M <sup>2</sup> 43,20	KG 602,66
Listello 3D 20x120 cm - 8"x47 <sup>1/4</sup> "	Thick 9 mm	RealUp + StrideUp	PZ / PCS 4	M <sup>2</sup> 1,44	KG 30,00	PZ / PCS 18	M <sup>2</sup> 25,93	KG 560,00
Muretto 30x30 cm - 11 <sup>7/8</sup> "x11 <sup>7/8</sup> "	Thick 9 mm	RealUp + StrideUp	PZ / PCS 6	M <sup>2</sup> 0,54	KG 10,20	PZ / PCS 60	M <sup>2</sup> 32,40	KG 632,00
Muretto 30x30 cm - 11 <sup>7/8</sup> "x11 <sup>7/8</sup> "	Thick 6 mm	RealUp + StrideUp	PZ / PCS 6	M <sup>2</sup> 0,54	KG 7,81	PZ / PCS 60	M <sup>2</sup> 32,04	KG 489,08
Mosaico / Mosaico Vein Cut 30x30 cm - 11 <sup>7/8</sup> "x11 <sup>7/8</sup> "	Thick 9 mm	RealUp + StrideUp	PZ / PCS 12	M <sup>2</sup> 1,08	KG 21,28	PZ / PCS 30	M <sup>2</sup> 32,40	KG 658,40

Imballi Mega / Mega Packing

DESCRIPTION	DESCRIPTION	MQ / KG	IMBALLO PIENO	IMBALLO VUOTO
LASTRA / SLAB	PACKAGING DESCRIPTION	LASTRA / SLAB	FULL PACKAGING	EMPTY PACKAGING
120x280x0,6 cm 47 <sup>1/4</sup> "x110 <sup>1/4</sup> "x1/4"	CASSA / CRATE L 145 x P 292 x H 35	MQ 3,36	MQ 67,20	
		KG 48,60	KG 1062,00	KG 100,00
120x280x0,6 cm 47 <sup>1/4</sup> "x110 <sup>1/4</sup> "x1/4"	CAVALLETTO / A-FRAME L 75 x P 285 x H 153	MQ 3,36	MQ 147,84	
		KG 48,60	KG 2318,40	KG 180,00
120x280x0,6 cm 47 <sup>1/4</sup> "x110 <sup>1/4</sup> "x1/4"	CASSA LIGHT / LIGHT CRATE L 145 x P 292 x H 27	MQ 3,36	MQ 30,24	
		KG 48,60	KG 527,40	KG 90,00
			PZ 1 / 9	

Stucchi consigliati / Recommended grouts

Colori Colors	Bianco Cross Cut / Bianco Vein Cut	Beige Cross Cut / Beige Vein Cut	Tortora Cross Cut / Tortora Vein Cut	Cenero Cross Cut / Cenero Vein Cut
Kerakoll	KK4	KK79	KK79	KK8
Mapei	111	123	187	112

Le tipologie di stucchi riportate nella tabella sono semplici suggerimenti. Prima della posa si raccomanda di eseguire un test di stuccatura per verificarne la compatibilità con la superficie ceramica e le condizioni di utilizzo. / The types of grout listed in the table are simply suggestions. Before installation, it is recommended to perform a grouting test to verify compatibility with the ceramic surface and conditions of use. / Die in der Tabelle aufgeführten Fugenmörteltypen sind lediglich Empfehlungen. Vor dem Verlegen wird empfohlen, einen Fugentest durchzuführen, um die Verträglichkeit mit der Keramikoberfläche und den Einsatzbedingungen zu überprüfen. / Les types de mastics indiqués dans le tableau sont de simples suggestions. Avant la pose, il est recommandé d'effectuer un test de masticage afin de vérifier la compatibilité avec la surface céramique et les conditions d'utilisation.

Pag. 415: approfondimenti calibri specifici / Pag. 415: further information on specific working sizes / S. 415: Vertiefungen über spezifische Werkmaße / Pag. 415: approfondissements dimensions de fabrication spécifiques



# Origins

Gres porcellanato - Rettificato / Porcelain Stoneware - Rectified  
 Feinsteinzeug - Kalibriert / Gres Cerame - Rectifié

New Innovative  
 Technology

RealUp®



Download  
 Catalogue

Conforming to Standards  
 EN 14411 ISO 13006 APPENDICE G GRUPPO BIa UGL CON Ev ≤ 0,5%

Caratteristiche tecniche  
 Technical features

BENDING STRENGTH	FROST RESISTANCE	CHEMICAL RESISTANCE	STAIN RESISTANCE	
ANSI A326.3 > 0,42	R10 / A+B	R11 / A+B+C	TRAFFICO INTENSO HEAVY TRAFFIC	V2 MODERATE
Naturale / Matte RealUp Antislip OPEN	RealUp	Antislip OPEN	Naturale / Matte RealUp Antislip OPEN	All Colours

Formati  
 Sizes

	6 mm	9 mm	20 mm - OPEN							
<b>SUPERFICIE SURFACE</b>	120x280x0,6 cm 47 1/4" x 110 1/8" x 1/4"	80x160 cm 31 1/2" x 63"	120x120 cm 47 1/4" x 47 1/4"	60x120 cm 23 1/2" x 47 1/4"	60x60 cm 23 1/2" x 23 1/2"	30x60 cm 11 7/8" x 23 1/2"	30x60 cm 11 7/8" x 23 1/2"	80x80 cm 31 1/2" x 31 1/2"	60x120 cm 23 1/2" x 47 1/4"	60x60 cm 23 1/2" x 23 1/2"
Naturale / Matte	■									
RealUp		■	■	■	■	■	■			
Line				■						
Antislip				■		■		■	■	

Colori  
 Colours

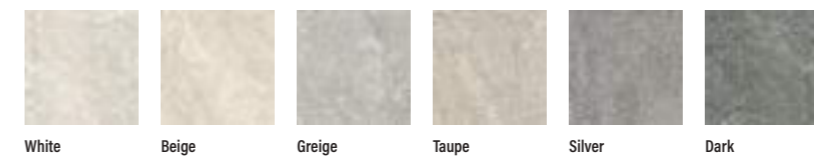

Superficie  
 Surface finishes



Silver 60x60 20 mm, Muretto 3D Silver 29x59



Muretto Dark 30x30, Dark 120x120, Nuances Muretto Salvia 30x30, Loom Piano 90



Silver 120x280x0,6, Silver 120x120, Nuances Salvia 120x280x0,6, Nuances Muretto Nero 30x30



White 120x280x0,6, Muretto White 30x30, Nuances Muretto Cipria 30x30, Loom Piano 180

White



White Line

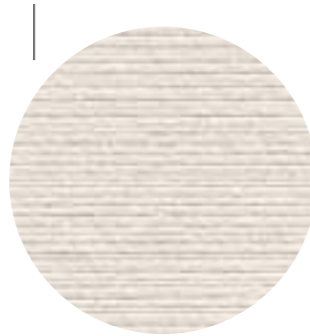

Il Decoro Line non garantisce continuità di struttura tra un pezzo e l'altro. / The Line Decor does not guarantee continuity of the structure between pieces. / Bei dem Dekor Line ist die Kontinuität der Linienstruktur zwischen einem Stück und dem nächsten nicht gewährleistet. / Le décor Line ne garanti aucune continuité entre une pièce et l'autre.

Beige



Beige Line



Il Decoro Line non garantisce continuità di struttura tra un pezzo e l'altro. / The Line Decor does not guarantee continuity of the structure between pieces. / Bei dem Dekor Line ist die Kontinuität der Linienstruktur zwischen einem Stück und dem nächsten nicht gewährleistet. / Le décor Line ne garanti aucune continuité entre une pièce et l'autre.

	6 mm	9 mm - RealUp					20 mm - OPEN				
	120x280x0,6 cm 47 1/4"x110 1/4"x1/4"	80x160 cm 31 1/2"x63"	120x120 cm 47 1/4"x47 1/4"	60x120 cm 23 1/2"x47 1/4"	60x60 cm 23 1/2"x23 1/2"	30x60 cm 11 7/8"x23 1/2"	30x60 cm 11 7/8"x23 1/2"	80x80 cm 31 1/2"x31 1/2"	60x120 cm 23 1/2"x47 1/4"	60x60 cm 23 1/2"x23 1/2"	Not rectified 
Naturale / Matte	UGL	OG01XPA ■ 110									
RealUp	UGL	OG01GA ■ 078	OG0112 ■ 078	OG01BA ■ 068	OG0168 ■ 052	OG0163 ■ 052		OG0188 ■ 062			
Line	UGL			OG01BALI ■ 080							
Antislip	UGL		OG01BAA ■ 068			OG0160A ■ 037		OG01BA2 ■ 095	OG01682 ■ 075		

	6 mm	9 mm - RealUp					20 mm - OPEN				
	120x280x0,6 cm 47 1/4"x110 1/4"x1/4"	80x160 cm 31 1/2"x63"	120x120 cm 47 1/4"x47 1/4"	60x120 cm 23 1/2"x47 1/4"	60x60 cm 23 1/2"x23 1/2"	30x60 cm 11 7/8"x23 1/2"	30x60 cm 11 7/8"x23 1/2"	80x80 cm 31 1/2"x31 1/2"	60x120 cm 23 1/2"x47 1/4"	60x60 cm 23 1/2"x23 1/2"	Not rectified 
Naturale / Matte	UGL	OG02XPA ■ 110									
RealUp	UGL	OG02GA ■ 078	OG0212 ■ 078	OG02BA ■ 068	OG0268 ■ 052	OG0263 ■ 052		OG0288 ■ 062			
Line	UGL			OG02BALI ■ 080							
Antislip	UGL		OG02BAA ■ 068			OG0260A ■ 037		OG02BA2 ■ 095	OG02682 ■ 075		

### Greige



### Greige Line

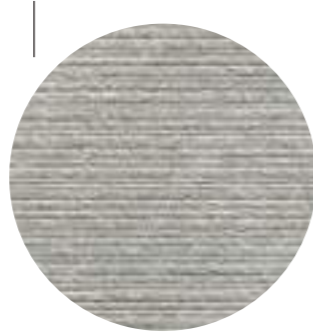

Il Decoro Line non garantisce continuità di struttura tra un pezzo e l'altro. / The Line Decor does not guarantee continuity of the structure between pieces. / Bei dem Dekor Line ist die Kontinuität der Linienstruktur zwischen einem Stück und dem nächsten nicht gewährleistet. / Le décor Line ne garanti aucune continuité entre une pièce et l'autre.

### Taupe



### Taupe Line

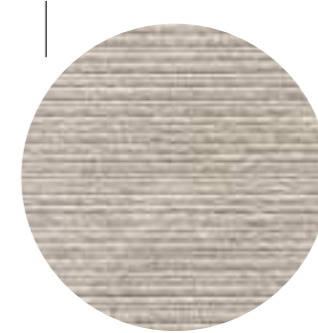

Il Decoro Line non garantisce continuità di struttura tra un pezzo e l'altro. / The Line Decor does not guarantee continuity of the structure between pieces. / Bei dem Dekor Line ist die Kontinuität der Linienstruktur zwischen einem Stück und dem nächsten nicht gewährleistet. / Le décor Line ne garanti aucune continuité entre une pièce et l'autre.

	6 mm	9 mm - RealUp	20 mm - OPEN							
	120x280x0,6 cm 47 1/8" x 110 1/4" x 1/4"	80x160 cm 31 1/2" x 63"	120x120 cm 47 1/8" x 47 1/8"	60x120 cm 23 1/2" x 47 1/8"	60x60 cm 23 1/2" x 23 1/2"	30x60 cm 11 7/8" x 23 1/2"	30x60 cm 11 7/8" x 23 1/2"	80x80 cm 31 1/2" x 31 1/2"	60x120 cm 23 1/2" x 47 1/8"	60x60 cm 23 1/2" x 23 1/2"
Naturale / Matte	UGL OG03XPA ■ 110									
RealUp	UGL	OG03GA ■ 078	OG0312 ■ 078	OG03BA ■ 068	OG0368 ■ 052	OG0363 ■ 052		OG0388 ■ 062		
Line	UGL			OG03BALI ■ 080						
Antislip	UGL			OG03BAA ■ 068		OG0360A ■ 037		OG03BA2 ■ 095	OG03682 ■ 075	

	9 mm - RealUp								
	80x160 cm 31 1/2" x 63"	120x120 cm 47 1/8" x 47 1/8"	60x120 cm 23 1/2" x 47 1/8"	60x60 cm 23 1/2" x 23 1/2"	30x60 cm 11 7/8" x 23 1/2"	30x60 cm 11 7/8" x 23 1/2"	30x60 cm 11 7/8" x 23 1/2"	80x80 cm 31 1/2" x 31 1/2"	
RealUp	UGL OG04GA ■ 078	OG0412 ■ 078	OG04BA ■ 068	OG0468 ■ 052	OG0463 ■ 052			OG0488 ■ 062	
Line	UGL		OG04BALI ■ 080						
Antislip	UGL		OG04BAA ■ 068					OG0460A ■ 037	

Silver



Silver Line

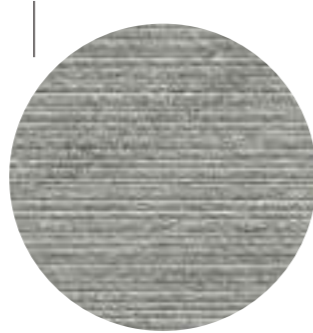

Il Decoro Line non garantisce continuità di struttura tra un pezzo e l'altro. / The Line Decor does not guarantee continuity of the structure between pieces. / Bei dem Dekor Line ist die Kontinuität der Linienstruktur zwischen einem Stück und dem nächsten nicht gewährleistet. / Le décor Line ne garanti aucune continuité entre une pièce et l'autre.

Dark



Dark Line

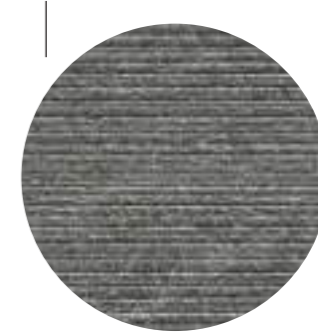

Il Decoro Line non garantisce continuità di struttura tra un pezzo e l'altro. / The Line Decor does not guarantee continuity of the structure between pieces. / Bei dem Dekor Line ist die Kontinuität der Linienstruktur zwischen einem Stück und dem nächsten nicht gewährleistet. / Le décor Line ne garanti aucune continuité entre une pièce et l'autre.

	6 mm	9 mm - RealUp	20 mm - OPEN							
	120x280x0,6 cm 47 1/8"x110 1/4"x1/4"	80x160 cm 31 1/2"x63"	120x120 cm 47 1/8"x47 1/8"	60x120 cm 23 1/2"x47 1/8"	60x60 cm 23 1/2"x23 1/2"	30x60 cm 11 7/8"x23 1/2"	30x60 cm 11 7/8"x23 1/2"	80x80 cm 31 1/2"x31 1/2"	60x120 cm 23 1/2"x47 1/8"	60x60 cm 23 1/2"x23 1/2"
Naturale / Matte	UGL OG05XPA ■ 110									
RealUp	UGL	OG05GA ■ 078	OG0512 ■ 078	OG05BA ■ 068	OG0568 ■ 052	OG0563 ■ 052		OG0588 ■ 062		
Line	UGL			OG05BALI ■ 080						
Antislip	UGL			OG05BAA ■ 068		OG0560A ■ 037		OG05BA2 ■ 095	OG05682 ■ 075	

	9 mm - RealUp					
	80x160 cm 31 1/2"x63"	120x120 cm 47 1/8"x47 1/8"	60x120 cm 23 1/2"x47 1/8"	60x60 cm 23 1/2"x23 1/2"	30x60 cm 11 7/8"x23 1/2"	80x80 cm 31 1/2"x31 1/2"
RealUp	UGL OG06GA ■ 078	OG0612 ■ 078	OG06BA ■ 068	OG0668 ■ 052	OG0663 ■ 052	OG0688 ■ 062
Line	UGL		OG06BALI ■ 080			
Antislip	UGL		OG06BAA ■ 068			

## Tapparella 3D

28,5x119,7



White  
9 mm

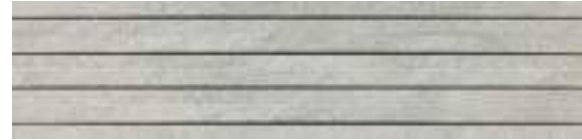

Greige  
9 mm

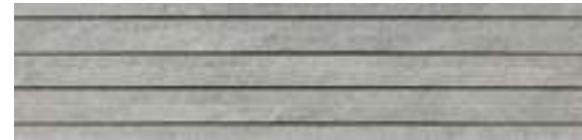

Silver  
9 mm



Beige  
9 mm



Taupe  
9 mm

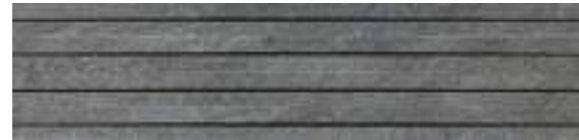

Dark  
9 mm

## Muretto 3D

29x59



White  
9 mm



Beige  
9 mm



Greige  
9 mm



Taupe  
9 mm



Silver  
9 mm



Dark  
9 mm

## Muretto

30x30



White  
6 mm / 9 mm



Beige  
6 mm / 9 mm



Greige  
6 mm / 9 mm



Silver  
6 mm / 9 mm



Silver  
9 mm



Dark  
9 mm

## Mosaico

30x30



White  
9 mm

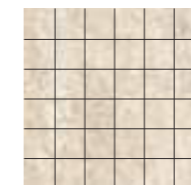

Beige  
9 mm



Greige  
9 mm



Taupe  
9 mm



Silver  
9 mm

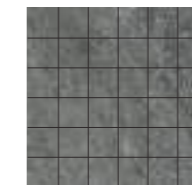

Dark  
9 mm

6 mm  
Naturale / Matte - UGL



Muretto  
30x30 cm  
11<sup>7/8</sup>"x11<sup>7/8</sup>"  
(Pcs Box 6)

9 mm  
RealUp - UGL



Muretto  
30x30 cm  
11<sup>7/8</sup>"x11<sup>7/8</sup>"  
(Pcs Box 6)



Mosaico  
30x30 cm  
11<sup>7/8</sup>"x11<sup>7/8</sup>"  
(Pcs Box 12)

9 mm  
Naturale / Matte - UGL



Tapparella 3D  
28,5x119,7cm  
11<sup>1/4</sup>"x47<sup>1/8</sup>"  
(Pcs Box 3)



Muretto 3D  
29x59 cm  
11<sup>3/8</sup>"x23<sup>1/4</sup>"  
(Pcs Box 4)

	OG01MB	OG01MA	OG01MB9	OG01MA9	OG01MTP	OG01MD
WHITE	OG01MB 043	OG01MA 137	OG01MB9 027	OG01MA9 137	OG01MTP 119	OG01MD 071
BEIGE	OG02MB 043	OG02MA 137	OG02MB9 027	OG02MA9 137	OG02MTP 119	OG02MD 071
GREIGE	OG03MB 043	OG03MA 137	OG03MB9 027	OG03MA9 137	OG03MTP 119	OG03MD 071
TAUPE			OG04MB9 027	OG04MA9 137	OG04MTP 119	OG04MD 071
SILVER	OG05MB 043	OG05MA 137	OG05MB9 027	OG05MA9 137	OG05MTP 119	OG05MD 071
DARK			OG06MB9 027	OG06MA9 137	OG06MTP 119	OG06MD 071



Su rete / Mesh mounted



Tessera  
2,8x9,8 1<sup>1/8</sup>"x3<sup>7/8</sup>"

Muretto



Tessera  
5x5 2"x2"

Mosaico



Tessera  
4,06x119,8 1<sup>5/8</sup>"x47<sup>1/8</sup>"  
3,06x119,8 1<sup>1/4</sup>"x47<sup>1/8</sup>"

Tapparella 3D



Tessera  
7,1x38,5 2<sup>3/4</sup>"x15<sup>1/8</sup>"  
7,1x19,9 2<sup>3/4</sup>"x7<sup>7/8</sup>"

Muretto 3D

Pezzi speciali / Special pieces

9 mm



Battiscopa  
7x60 cm  
2<sup>3/4</sup>"x23<sup>1/2</sup>"  
(Pcs Box 10)



Gradone con Toro  
120x33x4 cm  
47<sup>1/4</sup>"x13<sup>1/4</sup>"x1<sup>3/4</sup>"  
(Pcs Box 2)



Elemento "L"  
Incollato  
4,5x16,5x60 cm  
1<sup>3/4</sup>"x6<sup>1/2</sup>"x23<sup>1/2</sup>"  
(Pcs Box 4)

WHITE	RealUp + StrideUp	OG0176 ■ 009	OG01GT2 ■ 223	
	Antislip			OG01951 ■ 059
BEIGE	RealUp + StrideUp	OG0276 ■ 009	OG02GT2 ■ 223	
	Antislip			OG02951 ■ 059
GREIGE	RealUp + StrideUp	OG0376 ■ 009	OG03GT2 ■ 223	
	Antislip			OG03951 ■ 059
TAUPE	RealUp + StrideUp	OG0476 ■ 009	OG04GT2 ■ 223	
	Antislip			OG04951 ■ 059
SILVER	RealUp + StrideUp	OG0576 ■ 009	OG05GT2 ■ 223	
	Antislip			OG05951 ■ 059
DARK	RealUp + StrideUp	OG0676 ■ 009	OG06GT2 ■ 223	
	Antislip			OG06951 ■ 059

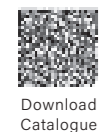

Download Catalogue

20 mm Open - Pezzi speciali / Special pieces

Per approfondimenti sui pezzi speciali e tutti gli accessori per esterno 20mm scarica la scheda tecnica oppure consultare il nostro sito e il catalogo Open.

For further information on special pieces and all 20mm outdoor accessories download the technical data sheet or consult our website and the Open catalog.

Für weitere Informationen zu Sonderteilen und dem gesamten 20mm Outdoor Zubehör laden Sie das technische Datenblatt herunter oder besuchen Sie unsere Website und den Open-Katalog.

Pour approfondissements sur les pièces de finition et accessoires pour extérieurs en 20mm, merci de télécharger la fiche technique ou bien consulter notre site web et le catalogue OPEN.



Line Beige 60x120

Imballi / Packing

				PCS / BOX	M <sup>2</sup> / BOX	KG / BOX	BOX / PALLET	M <sup>2</sup> / PALLET	KG / PALLET
	80x160 cm - 31 <sup>1/2</sup> "x62 <sup>7/8</sup> "	Thick 9 mm	RealUp	PZ / PCS 02	M <sup>2</sup> 2,56	KG 51,39	PZ / PCS 18	M <sup>2</sup> 46,08	KG 945,05
	120x120 cm - 47 <sup>1/4</sup> "x47 <sup>1/4</sup> "	Thick 9 mm	RealUp	PZ / PCS 02	M <sup>2</sup> 2,88	KG 59,23	PZ / PCS 18	M <sup>2</sup> 51,84	KG 1.086,24
	60x120 cm - 23 <sup>1/2</sup> "x47 <sup>1/4</sup> "	Thick 9 mm	RealUp / Line	PZ / PCS 02	M <sup>2</sup> 1,44	KG 28,54	PZ / PCS 36	M <sup>2</sup> 51,84	KG 1.047,58
	60x120 cm - 23 <sup>1/2</sup> "x47 <sup>1/4</sup> "	Thick 9 mm	Antislip	PZ / PCS 02	M <sup>2</sup> 1,44	KG 28,22	PZ / PCS 36	M <sup>2</sup> 51,84	KG 1.035,59
	OPEN 60x120 cm - 23 <sup>1/2</sup> "x47 <sup>1/4</sup> "	Thick 20 mm	Antislip	PZ / PCS 01	M <sup>2</sup> 0,72	KG 32,59	PZ / PCS 36	M <sup>2</sup> 25,92	KG 1.193,31
	80x80 cm - 31 <sup>1/2</sup> "x31 <sup>1/2</sup> "	Thick 9 mm	RealUp	PZ / PCS 02	M <sup>2</sup> 1,28	KG 25,77	PZ / PCS 42	M <sup>2</sup> 53,76	KG 1.102,42
	60x60 cm - 23 <sup>1/2</sup> "x23 <sup>1/2</sup> "	Thick 9 mm	RealUp	PZ / PCS 04	M <sup>2</sup> 1,44	KG 28,21	PZ / PCS 30	M <sup>2</sup> 43,20	KG 884,60
	30x60 cm - 11 <sup>7/8</sup> "x23 <sup>1/2</sup> "	Thick 9 mm	RealUp	PZ / PCS 08	M <sup>2</sup> 1,44	KG 25,48	PZ / PCS 32	M <sup>2</sup> 46,08	KG 931,64
	Not rectified 30x60 cm - 11 <sup>7/8</sup> "x23 <sup>1/2</sup> "	Thick 9 mm	Antislip	PZ / PCS 08	M <sup>2</sup> 1,44	KG 26,80	PZ / PCS 32	M <sup>2</sup> 46,08	KG 877,60
	Muretto 3D 29x59 cm - 11 <sup>3/8</sup> "x23 <sup>1/4</sup> "	Thick 9 mm	RealUp	PZ / PCS 04	M <sup>2</sup> 0,68	KG 13,04	PZ / PCS 18	M <sup>2</sup> 12,31	KG 254,72
	Tapparella 3D 28,5x19,7 cm - 11 <sup>1/8</sup> "x47 <sup>1/8</sup> "	Thick 9 mm	RealUp	PZ / PCS 03	M <sup>2</sup> 1,02	KG 19,86	PZ / PCS 26	M <sup>2</sup> 26,59	KG 536,36
	Muretto 30x30 cm - 11 <sup>7/8</sup> "x11 <sup>7/8</sup> "	Thick 6 mm	Naturale	PZ / PCS 06	M <sup>2</sup> 0,54	KG 7,81	PZ / PCS 60	M <sup>2</sup> 32,40	KG 489,08
	Muretto 30x30 cm - 11 <sup>7/8</sup> "x11 <sup>7/8</sup> "	Thick 9 mm	RealUp	PZ / PCS 06	M <sup>2</sup> 0,54	KG 9,70	PZ / PCS 60	M <sup>2</sup> 32,40	KG 602,12
	Mosaico 30x30 cm - 11 <sup>7/8</sup> "x11 <sup>7/8</sup> "	Thick 9 mm	RealUp	PZ / PCS 12	M <sup>2</sup> 1,08	KG 20,62	PZ / PCS 30	M <sup>2</sup> 32,40	KG 638,60

Imballi Mega / Mega Packing

	DESCRIZIONE IMBALLO PACKAGING DESCRIPTION	MQ / KG LASTRA / SLAB	IMBALLO PIENO FULL PACKAGING	IMBALLO VUOTO EMPTY PACKAGING
	CASSA / CRATE L 145 x P 292 x H 35	MQ 3,36	MQ 67,20	
		KG 48,60	KG 1062,00	KG 100,00
	CAVALLETTO / A-FRAME L 75 x P 285 x H 153	MQ 3,36	MQ 147,84	
		KG 48,60	KG 2318,40	KG 180,00
	CASSA LIGHT / LIGHT CRATE L 145 x P 292 x H 27	MQ 3,36	MQ 30,24	
		KG 48,60	KG 527,40	KG 90,00
			PZ 1 / 9	

Stucchi consigliati / Recommended grouts

Colori Colors	White	Beige	Greige	Taupe	Silver	Dark
<b>Kerakoll</b>	KK6	KK109	KK8	KK66	KK68	KK72
<b>Mapei</b>	80% 100 + 20% 110	50% 100 + 50% 110	80% 100 + 20% 112	90% 110 + 10% 112	80% 112 + 20% 100	70% 100 + 30% 119

Le tipologie di stucchi riportate nella tabella sono semplici suggerimenti. Prima della posa si raccomanda di eseguire un test di stuccatura per verificarne la compatibilità con la superficie ceramica e le condizioni di utilizzo. / The types of grout listed in the table are simply suggestions. Before installation, it is recommended to perform a grouting test to verify compatibility with the ceramic surface and conditions of use. / Die in der Tabelle aufgeführten Fugenmörteltypen sind lediglich Empfehlungen. Vor dem Verlegen wird empfohlen, einen Fugentest durchzuführen, um die Verträglichkeit mit der Keramikoberfläche und den Einsatzbedingungen zu überprüfen. / Les types de mastics indiqués dans le tableau sont de simples suggestions. Avant la pose, il est recommandé d'effectuer un test de masticage afin de vérifier la compatibilité avec la surface céramique et les conditions d'utilisation.

Pag. 415: approfondimenti calibri specifici / Pag. 415: further information on specific working sizes / S. 415: Vertiefungen über spezifische Werkmaße / Pag. 415 : approfondissements dimensions de fabrication spécifiques



Sand 120x280x0,6, 120x120

# Shale

Gres porcellanato - Rettificato / Porcelain Stoneware - Rectified  
 Feinsteinzeug - Kalibriert / Gres Cerame - Rectifié

Conforming to Standards  
 EN 14411 ISO 13006 APPENDICE G GRUPPO BIa UGL CON Ev ≤ 0,5%



Download  
 Catalogue

Caratteristiche tecniche  
 Technical features

BENDING STRENGTH	FROST RESISTANCE	CHEMICAL RESISTANCE	STAIN RESISTANCE
ANSI A326.3 > 0,42	R11 / A+B+C	TRAFFICO INTENSO HEAVY TRAFFIC	V3 HIGH
Naturale / Matte Antislip OPEN	Antislip OPEN	Naturale / Matte Antislip	All Colours

Formati  
 Sizes

	6 mm	9 mm	20 mm - OPEN
<b>SUPERFICIE SURFACE</b>	120x280x0,6 cm 47 <sup>1/4</sup> "x110 <sup>1/4</sup> "x1/4"	120x120 cm 47 <sup>1/4</sup> "x47 <sup>1/4</sup> "	80x160 cm 31 <sup>1/2</sup> "x63"
		80x80 cm 31 <sup>1/2</sup> "x31 <sup>1/2</sup> "	60x120 cm 23 <sup>1/2</sup> "x47 <sup>1/4</sup> "
		60x60 cm 23 <sup>1/2</sup> "x23 <sup>1/2</sup> "	30x60 cm 11 <sup>7/8</sup> "x23 <sup>1/2</sup> "
			30x60 cm 11 <sup>7/8</sup> "x23 <sup>1/2</sup> "
			15x60 cm 6"x23 <sup>1/2</sup> "
			10x30 cm 4"x11 <sup>7/8</sup> "
			60x120 cm 23 <sup>1/2</sup> "x47 <sup>1/4</sup> "
			60x60 cm 23 <sup>1/2</sup> "x23 <sup>1/2</sup> "
<b>Naturale / Matte</b>	■	■	■
<b>Ribbed</b>			■
<b>Antislip</b>		■ <small>(new)</small>	■

Colori  
 Colours



Superficie  
 Surface finishes





Taupe 60x120 20mm, Taupe Ribbed 60x120, Moon Muretto a spacco 30x30



Moon Ribbed 60x120



Ash 60x120

Moon

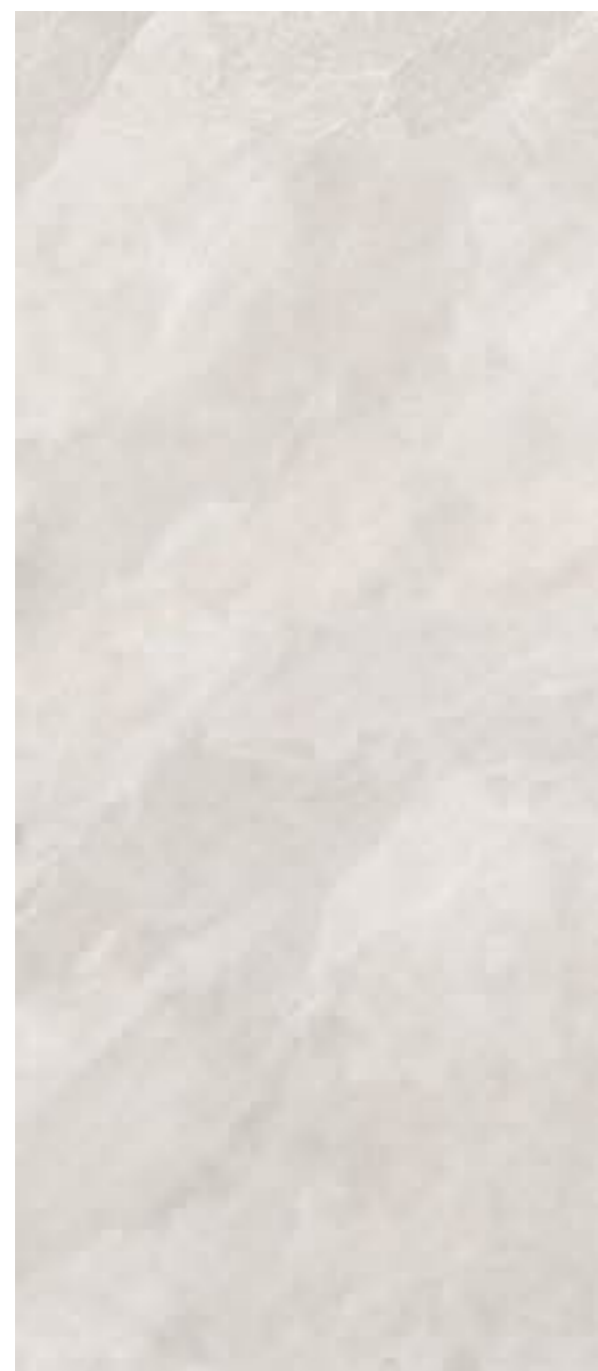

Moon Ribbed



Il Decoro Ribbed non garantisce continuità di struttura tra un pezzo e l'altro. / The Ribbed Decor does not guarantee continuity of the structure between pieces. / Bei dem Dekor Ribbed ist die Kontinuität der Linienstruktur zwischen einem Stück und dem nächsten nicht gewährleistet. / Le décor Ribbed ne garanti aucune continuité entre une pièce et l'autre.

Sand



Sand Ribbed



Il Decoro Ribbed non garantisce continuità di struttura tra un pezzo e l'altro. / The Ribbed Decor does not guarantee continuity of the structure between pieces. / Bei dem Dekor Ribbed ist die Kontinuität der Linienstruktur zwischen einem Stück und dem nächsten nicht gewährleistet. / Le décor Ribbed ne garanti aucune continuité entre une pièce et l'autre.

	6 mm	9 mm	Not rectified															
	120x280x0,6 cm 47 1/4"x110 1/4"x1/4"	120x120 cm 47 1/4"x47 1/4"	80x160 cm 31 1/2"x63"	80x80 cm 31 1/2"x31 1/2"	60x120 cm 23 1/2"x47 1/4"	60x60 cm 23 1/2"x23 1/2"	30x60 cm 11 7/8"x23 1/2"	30x60 cm 11 7/8"x23 1/2"	15x60 cm 6"x23 1/2"	10x30 cm 4"x11 7/8"								
Naturale / Matte	UGL SL01XPA ■ 110	SL0112 ■ 078	SL01GA ■ 078	SL0188 ■ 062	SL01BA ■ 068	SL0168 ■ 052	SL0163 ■ 052		SL01L15 ■ 077	SL01L3 ■ 080								
Ribbed	UGL				SL01BAR ■ 080	SL0163R ■ 080												
Antislip	UGL	SL0112A ■ 078			SL01BAA ■ 068			SL0160A ■ 037										

	6 mm	9 mm	Not rectified										20 mm - OPEN					
	120x280x0,6 cm 47 1/4"x110 1/4"x1/4"	120x120 cm 47 1/4"x47 1/4"	80x160 cm 31 1/2"x63"	80x80 cm 31 1/2"x31 1/2"	60x120 cm 23 1/2"x47 1/4"	60x60 cm 23 1/2"x23 1/2"	30x60 cm 11 7/8"x23 1/2"	30x60 cm 11 7/8"x23 1/2"	15x60 cm 6"x23 1/2"	10x30 cm 4"x11 7/8"								
Naturale / Matte	UGL SL02XPA ■ 110	SL0212 ■ 078	SL02GA ■ 078	SL0288 ■ 062	SL02BA ■ 068	SL0268 ■ 052	SL0263 ■ 052		SL02L15 ■ 077	SL02L3 ■ 080								
Ribbed	UGL				SL02BAR ■ 080	SL0263R ■ 080												
Antislip	UGL	SL0212A ■ 078			SL02BAA ■ 068			SL0260A ■ 037						SL02BA2 ■ 095	SL02682 ■ 075			

Taupe



Taupe Ribbed

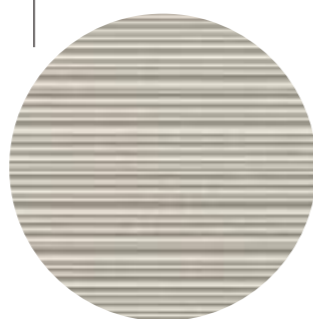

Il Decoro Ribbed non garantisce continuità di struttura tra un pezzo e l'altro. / The Ribbed Decor does not guarantee continuity of the structure between pieces. / Bei dem Dekor Ribbed ist die Kontinuität der Linienstruktur zwischen einem Stück und dem nächsten nicht gewährleistet. / Le décor Ribbed ne garanti aucune continuité entre une pièce et l'autre.

Greige



Greige Ribbed

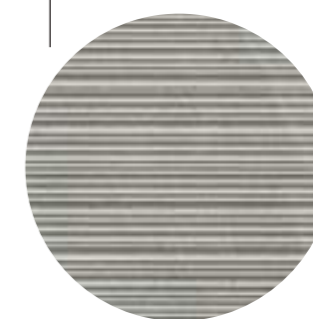

Il Decoro Ribbed non garantisce continuità di struttura tra un pezzo e l'altro. / The Ribbed Decor does not guarantee continuity of the structure between pieces. / Bei dem Dekor Ribbed ist die Kontinuität der Linienstruktur zwischen einem Stück und dem nächsten nicht gewährleistet. / Le décor Ribbed ne garanti aucune continuité entre une pièce et l'autre.

	6 mm	9 mm	20 mm - OPEN																			
	120x280x0,6 cm 47 1/4"x110 1/4"x1/4"	120x120 cm 47 1/4"x47 1/4"	80x160 cm 31 1/2"x63"	80x80 cm 31 1/2"x31 1/2"	60x120 cm 23 1/2"x47 1/4"	60x60 cm 23 1/2"x23 1/2"	30x60 cm 11 7/8"x23 1/2"	30x60 cm 11 7/8"x23 1/2"	30x60 cm 11 7/8"x23 1/2"	15x60 cm 6"x23 1/2"	10x30 cm 4"x11 7/8"	60x120 cm 23 1/2"x47 1/4"	60x60 cm 23 1/2"x23 1/2"	Not rectified							60x120 cm 23 1/2"x47 1/4"	60x60 cm 23 1/2"x23 1/2"
Naturale / Matte	UGL SL06XPA ■ 110	SL0612 ■ 078	SL06GA ■ 078	SL0688 ■ 062	SL06BA ■ 068	SL0668 ■ 052	SL0663 ■ 052					SL06L15 ■ 077	SL06L3 ■ 080									
Ribbed	UGL				SL06BAR ■ 080											SL0663R ■ 080						
Antislip	UGL				SL06BAA ■ 068											SL0660A ■ 037						

	6 mm	9 mm	20 mm - OPEN																			
	120x280x0,6 cm 47 1/4"x110 1/4"x1/4"	120x120 cm 47 1/4"x47 1/4"	80x160 cm 31 1/2"x63"	80x80 cm 31 1/2"x31 1/2"	60x120 cm 23 1/2"x47 1/4"	60x60 cm 23 1/2"x23 1/2"	30x60 cm 11 7/8"x23 1/2"	30x60 cm 11 7/8"x23 1/2"	30x60 cm 11 7/8"x23 1/2"	15x60 cm 6"x23 1/2"	10x30 cm 4"x11 7/8"	60x120 cm 23 1/2"x47 1/4"	60x60 cm 23 1/2"x23 1/2"	Not rectified							60x120 cm 23 1/2"x47 1/4"	60x60 cm 23 1/2"x23 1/2"
Naturale / Matte	UGL SL03XPA ■ 110	SL0312 ■ 078	SL03GA ■ 078	SL0388 ■ 062	SL03BA ■ 068	SL0368 ■ 052	SL0363 ■ 052					SL03L15 ■ 077	SL03L3 ■ 080									
Ribbed	UGL				SL03BAR ■ 080											SL0363R ■ 080						
Antislip	UGL				SL0312A ■ 078											SL03BAA ■ 068						

Ash



Ash Ribbed

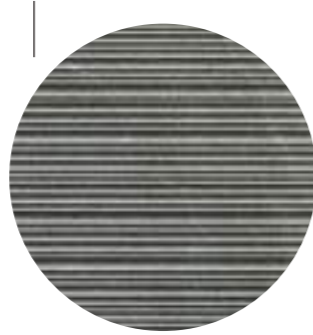
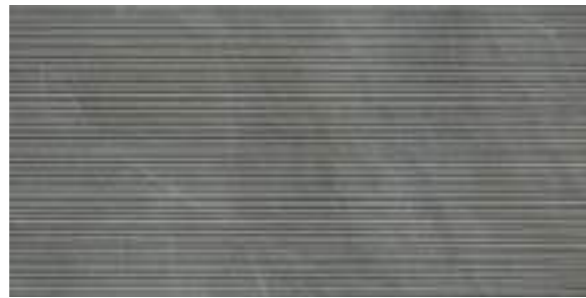

Il Decoro Ribbed non garantisce continuità di struttura tra un pezzo e l'altro. / The Ribbed Decor does not guarantee continuity of the structure between pieces. / Bei dem Dekor Ribbed ist die Kontinuität der Linienstruktur zwischen einem Stück und dem nächsten nicht gewährleistet. / Le décor Ribbed ne garanti aucune continuité entre une pièce et l'autre.

Dark

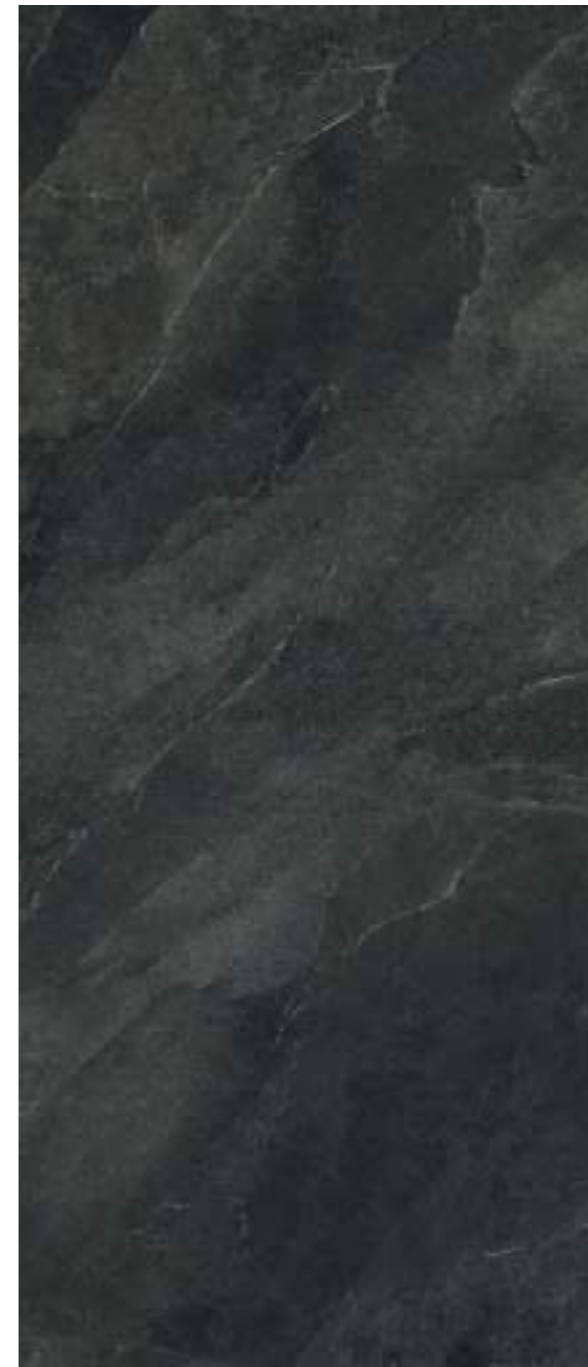

Dark Ribbed

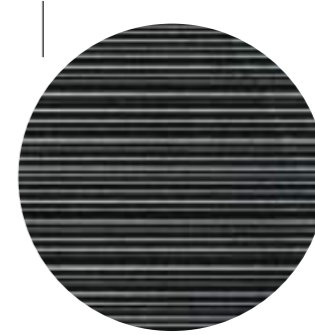

Il Decoro Ribbed non garantisce continuità di struttura tra un pezzo e l'altro. / The Ribbed Decor does not guarantee continuity of the structure between pieces. / Bei dem Dekor Ribbed ist die Kontinuität der Linienstruktur zwischen einem Stück und dem nächsten nicht gewährleistet. / Le décor Ribbed ne garanti aucune continuité entre une pièce et l'autre.

	6 mm	9 mm	Not rectified																
	120x280x0,6 cm 47 1/4" x 110 1/4" x 1/4"	120x120 cm 47 1/4" x 47 1/4"	80x160 cm 31 1/2" x 63"	80x80 cm 31 1/2" x 31 1/2"	60x120 cm 23 1/2" x 47 1/4"	60x60 cm 23 1/2" x 23 1/2"	30x60 cm 11 7/8" x 23 1/2"	30x60 cm 11 7/8" x 23 1/2"	15x60 cm 6" x 23 1/2"	10x30 cm 4" x 11 7/8"									
Naturale / Matte	UGL SL04XPA ■ 110	SL0412 ■ 078	SL04GA ■ 078	SL0488 ■ 062	SL04BA ■ 068	SL0468 ■ 052	SL0463 ■ 052				SL04L15 ■ 077	SL04L3 ■ 080							
Ribbed	UGL				SL04BAR ■ 080		SL0463R ■ 080												
Antislip	UGL				SL04BAA ■ 068		SL0460A ■ 037												

	6 mm	9 mm	Not rectified																
	120x280x0,6 cm 47 1/4" x 110 1/4" x 1/4"	120x120 cm 47 1/4" x 47 1/4"	80x160 cm 31 1/2" x 63"	80x80 cm 31 1/2" x 31 1/2"	60x120 cm 23 1/2" x 47 1/4"	60x60 cm 23 1/2" x 23 1/2"	30x60 cm 11 7/8" x 23 1/2"	30x60 cm 11 7/8" x 23 1/2"	15x60 cm 6" x 23 1/2"	10x30 cm 4" x 11 7/8"									
Naturale / Matte	UGL SL05XPA ■ 110	SL0512 ■ 078	SL05GA ■ 078	SL0588 ■ 062	SL05BA ■ 068	SL0568 ■ 052	SL0563 ■ 052	SL05L15 ■ 077	SL05L3 ■ 080										
Ribbed	UGL				SL05BAR ■ 080		SL0563R ■ 080												
Antislip	UGL				SL05BAA ■ 068														

## Muretto a spacco

30x30



Moon



Sand



Taupe



Greige

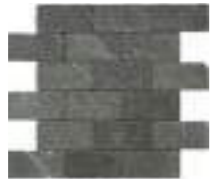

Ash



Dark

## Mosaico

30x30



Moon



Sand



Taupe



Greige



Ash



Dark

### ■ 9 mm Naturale / Matte - UGL



Muretto a spacco  
30x30 cm  
11<sup>7/8</sup>"x11<sup>7/8</sup>"  
(Pcs Box 12)



Mosaico  
30x30 cm  
11<sup>7/8</sup>"x11<sup>7/8</sup>"  
(Pcs Box 12)

<b>MOON</b>	SL01MS	180	SL013MA	137
<b>SAND</b>	SL02MS	180	SL023MA	137
<b>TAUPE</b>	SL06MS	180	SL063MA	137
<b>GREIGE</b>	SL03MS	180	SL033MA	137
<b>ASH</b>	SL04MS	180	SL043MA	137
<b>DARK</b>	SL05MS	180	SL053MA	137



Su rete / Mesh mounted



Tessera  
10x5 4"x2"

Muretto a spacco



Tessera  
5x5 2"x2"

Mosaico

## Stucchi consigliati / Recommended grouts

Colori Colors	Moon	Sand	Taupe	Greige	Ash	Dark
<b>Kerakoll</b>	KK6	KK79	KK81	KK69	KK10	KK12
<b>Mapei</b>	110	110	80% 112 + 20% 110	112	90% 119 + 10% 110	119

Le tipologie di stucchi riportate nella tabella sono semplici suggerimenti. Prima della posa si raccomanda di eseguire un test di stuccatura per verificarne la compatibilità con la superficie ceramica e le condizioni di utilizzo. / The types of grout listed in the table are simply suggestions. Before installation, it is recommended to perform a grouting test to verify compatibility with the ceramic surface and conditions of use. / Die in der Tabelle aufgeführten Fugenmörteltypen sind lediglich Empfehlungen. Vor dem Verlegen wird empfohlen, einen Fugentest durchzuführen, um die Verträglichkeit mit der Keramikoberfläche und den Einsatzbedingungen zu überprüfen. / Les types de mastics indiqués dans le tableau sont de simples suggestions. Avant la pose, il est recommandé d'effectuer un test de masticage afin de vérifier la compatibilité avec la surface céramique et les conditions d'utilisation.

## Pezzi speciali / Special pieces

■ 9 mm

Battiscopa  
7x60 cm  
2<sup>3/4</sup>"x23<sup>1/2</sup>"  
(Pcs Box 10)

Gradone  
con Toro  
120x33x4 cm  
47<sup>1/4</sup>"x13<sup>1/4</sup>"  
(Pcs Box 2)

Elemento "L"  
Incollato  
4,5x16,5x60 cm  
1<sup>3/4</sup>"x6<sup>1/2</sup>"x23<sup>1/2</sup>"  
(Pcs Box 4)

Elemento "L"  
Incollato  
4,5x16,5x120 cm  
1<sup>3/4</sup>"x6<sup>1/2</sup>"x47<sup>1/4</sup>"  
(Pcs Box 2)

<b>MOON</b>	Naturale / Matte	SL0176 ■ 009	SL01GT2 ■ 223	
	Antislip			SL0195I ■ 059 SL01EL120 ■ 143
<b>SAND</b>	Naturale / Matte	SL0276 ■ 009	SL02GT2 ■ 223	
	Antislip			SL0295I ■ 059 SL02EL120 ■ 143
<b>TAUPE</b>	Naturale / Matte	SL0676 ■ 009	SL06GT2 ■ 223	
	Antislip			SL0695I ■ 059
<b>GREIGE</b>	Naturale / Matte	SL0376 ■ 009	SL03GT2 ■ 223	
	Antislip			SL0395I ■ 059 SL03EL120 ■ 143
<b>ASH</b>	Naturale / Matte	SL0476 ■ 009	SL04GT2 ■ 223	
	Antislip			SL0495I ■ 059
<b>DARK</b>	Naturale / Matte	SL0576 ■ 009	SL05GT2 ■ 223	



Download  
Catalogue

## 20 mm Open - Pezzi speciali / Special pieces

Per approfondimenti sui pezzi speciali e tutti gli accessori per esterno 20mm scarica la scheda tecnica oppure consultare il nostro sito e il catalogo Open.

For further information on special pieces and all 20mm outdoor accessories download the technical data sheet or consult our website and the Open catalog.

Für weitere Informationen zu Sonderteilen und dem gesamten 20mm Outdoor-Zubehör laden Sie das technische Datenblatt herunter oder besuchen Sie unsere Website und den Open-Katalog.

Pour approfondissements sur les pièces de finition et accessoires pour extérieurs en 20mm merci de télécharger la fiche technique ou bien consulter notre site web et le catalogue OPEN.

## Imballi / Packing

				PCS / BOX	M <sup>2</sup> / BOX	KG / BOX	BOX / PALLET	M <sup>2</sup> / PALLET	KG / PALLET
	120x120 cm - 47 <sup>1/4</sup> "x47 <sup>1/4</sup> "	Thick 9 mm	Naturale / Antislip	PZ / PCS 02	M <sup>2</sup> 2,88	KG 60,41	PZ / PCS 18	M <sup>2</sup> 51,84	KG 1107,39
	80x160 cm - 31 <sup>1/2</sup> "x62 <sup>7/8</sup> "	Thick 9 mm	Naturale	PZ / PCS 02	M <sup>2</sup> 2,56	KG 50,36	PZ / PCS 18	M <sup>2</sup> 46,08	KG 926,48
	80x80 cm - 31 <sup>1/2</sup> "x62 <sup>7/8</sup> "	Thick 9 mm	Naturale	PZ / PCS 02	M <sup>2</sup> 1,28	KG 25,32	PZ / PCS 42	M <sup>2</sup> 53,76	KG 1083,73
	60x120 cm - 23 <sup>1/2</sup> "x47 <sup>1/4</sup> "	Thick 9 mm	Naturale / Ribbed / Antislip	PZ / PCS 02	M <sup>2</sup> 1,44	KG 28,27	PZ / PCS 36	M <sup>2</sup> 51,84	KG 1037,86
	OPEN 60x120 cm - 23 <sup>1/2</sup> "x47 <sup>1/4</sup> "	Thick 20 mm	Antislip	PZ / PCS 01	M <sup>2</sup> 0,72	KG 32,11	PZ / PCS 36	M <sup>2</sup> 25,92	KG 1176,17
	60x60 cm - 23 <sup>1/2</sup> "x23 <sup>1/2</sup> "	Thick 9 mm	Naturale	PZ / PCS 04	M <sup>2</sup> 1,44	KG 22,92	PZ / PCS 30	M <sup>2</sup> 43,20	KG 857,66
	OPEN 60x60 cm - 23 <sup>1/2</sup> "x23 <sup>1/2</sup> "	Thick 20 mm	Antislip	PZ / PCS 02	M <sup>2</sup> 0,72	KG 30,13	PZ / PCS 30	M <sup>2</sup> 21,60	KG 984,00
	30x60 cm - 11 <sup>7/8</sup> "x23 <sup>1/2</sup> "	Thick 9 mm	Naturale / Ribbed	PZ / PCS 08	M <sup>2</sup> 1,44	KG 27,81	PZ / PCS 32	M <sup>2</sup> 46,08	KG 910,08
Not rectified	30x60 cm - 11 <sup>7/8</sup> "x23 <sup>1/2</sup> "	Thick 9 mm	Antislip	PZ / PCS 08	M <sup>2</sup> 1,44	KG 26,23	PZ / PCS 32	M <sup>2</sup> 46,08	KG 910,08
	15x60 cm - 6"x23 <sup>1/2</sup> "	Thick 9 mm	Naturale	PZ / PCS 12	M <sup>2</sup> 1,08	KG 21,72	PZ / PCS 40	M <sup>2</sup> 43,20	KG 849,00
	10x30 cm - 4"x11 <sup>7/8</sup> "	Thick 9 mm	Naturale	PZ / PCS 30	M <sup>2</sup> 0,90	KG 18,00	PZ / PCS 48	M <sup>2</sup> 43,20	KG 895,66
	Muretto a Spacco 30x30 cm - 11 <sup>7/8</sup> "x11 <sup>7/8</sup> "	Thick 9 mm	Naturale	PZ / PCS 12	M <sup>2</sup> 1,08	KG 21,00	PZ / PCS 30	M <sup>2</sup> 32,40	KG 650,00
	Mosaico 30x30 cm - 11 <sup>7/8</sup> "x11 <sup>7/8</sup> "	Thick 9 mm	Naturale	PZ / PCS 12	M <sup>2</sup> 1,08	KG 20,30	PZ / PCS 30	M <sup>2</sup> 32,40	KG 629,00

## Imballi Mega / Mega Packing

	DESCRIZIONE IMBALLO PACKAGING DESCRIPTION	MQ / KG LASTRA / SLAB	IMBALLO PIENO FULL PACKAGING	IMBALLO VUOTO EMPTY PACKAGING
	CASSA / CRATE L 145 x P 292 x H 35	MQ 3,36	MQ 67,20	
		KG 48,60	KG 1062,00	KG 100,00
	CAVALLETTO / A-FRAME L 75 x P 285 x H 153	MQ 3,36	MQ 147,84	
		KG 48,60	KG 2318,40	KG 180,00
			PZ 44	
	CASSA LIGHT / LIGHT CRATE L 145 x P 292 x H 27	MQ 3,36	MQ 30,24	
		KG 48,60	KG 527,40	KG 90,00
			PZ 1 / 9	

Pag. 415: approfondimenti calibri specifici / Pag. 415: further information on specific working sizes / S. 415: Vertiefungen über spezifische Werkmaße / Pag. 415: approfondissements dimensions de fabrication spécifiques



# Silver Grain + Ceppo di Gré

Gres porcellanato - Rettificato / Porcelain Stoneware - Rectified  
 Feinsteinzeug - Kalibriert / Gres Cerame - Rectifié

Conforming to Standards  
 EN 14411 ISO 13006 APPENDICE G GRUPPO BIa UGL CON Ev ≤ 0,5%



Download  
 Catalogue

Caratteristiche tecniche  
 Technical features

BENDING STRENGTH	FROST RESISTANCE	CHEMICAL RESISTANCE	STAIN RESISTANCE
ANSI A326.3 > 0,42	R11 / A+B+C	TRAFFICO INTENSO HEAVY TRAFFIC	V2 MODERATE
Naturale / Matte Antislip OPEN	Antislip OPEN	Naturale / Matte Antislip OPEN	All Colours

Formati  
 Sizes

	6 mm - MEGA		9 mm		20 mm - OPEN	
<b>SUPERFICIE</b>	120x280x0,6 cm	120x120 cm	60x120 cm	80x80 cm	60x60 cm	30x60 cm
<b>SURFACE</b>	47 1/4" x 110 1/4" x 1/4"	47 1/4" x 47 1/4"	23 1/2" x 47 1/4"	31 1/2" x 31 1/2"	23 1/2" x 23 1/2"	11 7/8" x 23 1/2"
	20x120 cm	60x120 cm	60x60 cm	60x60 cm	60x60 cm	60x60 cm
	8" x 47 1/4"	23 1/2" x 47 1/4"	23 1/2" x 23 1/2"	23 1/2" x 23 1/2"	23 1/2" x 23 1/2"	23 1/2" x 23 1/2"
<b>SILVER GRAIN</b>	Naturale / Matte	Listello Mix	Antislip			
<b>CEPPO DI GRÉ</b>	Naturale / Matte		Antislip			

Colori  
 Colours

Silver Grain	Ceppo di Gré
White	Grey
Beige	
Grey	
Taupe	
Dark	

Superficie  
 Surface finishes

Silver Grain	Ceppo di Gré
Naturale Matte	Naturale Matte
Antislip	Antislip
Listello Mix	

Ceppo Di Gré Grey 120x280x0,6, Silver Grain Grey 120x120



Silver Grain White 120x280x0,6, 120x120, Silver Grain White Listello Mix 20x120, Ceppo Di Gré Flow

Silver Grain White



Silver Grain Beige



Silver Grain Grey



Silver Grain Taupe



		6 mm - MEGA		9 mm			
		120x280x0,6 cm 47 1/4" x 110 1/4" x 1/4"	120x120 cm 47 1/4" x 47 1/4"	60x120 cm 23 1/2" x 47 1/4"	80x80 cm 31 1/2" x 31 1/2"	60x60 cm 23 1/2" x 23 1/2"	30x60 cm 11 7/8" x 23 1/2"
Naturale / Matte	UGL	WHITE SI01XPA ■ 110	SI0112 ■ 078	SI01BA ■ 068	SI0188 ■ 062	SI0168 ■ 052	SI0163 ■ 052
		BEIGE	SI0212 ■ 078	SI02BA ■ 068	SI0288 ■ 062	SI0268 ■ 052	SI0263 ■ 052
Antislip	UGL	WHITE SI01BAA ■ 068		SI0168A ■ 052			
		BEIGE	SI02BAA ■ 068		SI0268A ■ 052		

		6 mm - MEGA		9 mm		20 mm - OPEN	
		120x280x0,6 cm 47 1/4" x 110 1/4" x 1/4"	120x120 cm 47 1/4" x 47 1/4"	60x120 cm 23 1/2" x 47 1/4"	80x80 cm 31 1/2" x 31 1/2"	60x60 cm 23 1/2" x 23 1/2"	30x60 cm 11 7/8" x 23 1/2"
Naturale / Matte	UGL	GREY SI03XPA ■ 110	SI0312 ■ 078	SI03BA ■ 068	SI0388 ■ 062	SI0368 ■ 052	SI0363 ■ 052
		TAUPE	SI0412 ■ 078	SI04BA ■ 068	SI0488 ■ 062	SI0468 ■ 052	SI0463 ■ 052
Antislip	UGL	GREY SI03BAA ■ 068		SI0368A ■ 052			
		TAUPE	SI0468A ■ 052				

Silver Grain Dark



Ceppo di Gré Grey



		6 mm - MEGA	9 mm				
		120x280x0,6 cm 47 <sup>1/8</sup> "x110 <sup>1/8</sup> "x1/4"	120x120 cm 47 <sup>1/8</sup> "x47 <sup>1/8</sup> "	60x120 cm 23 <sup>1/8</sup> "x47 <sup>1/8</sup> "	80x80 cm 31 <sup>1/8</sup> "x31 <sup>1/8</sup> "	60x60 cm 23 <sup>1/8</sup> "x23 <sup>1/8</sup> "	30x60 cm 11 <sup>1/8</sup> "x23 <sup>1/8</sup> "
Naturale / Matte	UGL	SI05XPA ■ 110	SI0512 ■ 078	SI05BA ■ 068	SI0588 ■ 062	SI0568 ■ 052	SI0563 ■ 052
Antislip	UGL					SI0568A ■ 052	

		6 mm - MEGA	9 mm				20 mm - OPEN
		120x280x0,6 cm 47 <sup>1/8</sup> "x110 <sup>1/8</sup> "x1/4"	120x120 cm 47 <sup>1/8</sup> "x47 <sup>1/8</sup> "	60x120 cm 23 <sup>1/8</sup> "x47 <sup>1/8</sup> "	80x80 cm 31 <sup>1/8</sup> "x31 <sup>1/8</sup> "	60x60 cm 23 <sup>1/8</sup> "x23 <sup>1/8</sup> "	60x120 cm 23 <sup>1/8</sup> "x47 <sup>1/8</sup> "
Naturale / Matte	UGL	CG01XPA ■ 110	CG0112 ■ 078	CG01BA ■ 068	CG0188 ■ 062	CG0168 ■ 052	
Antislip	UGL						CG01BA2 ■ 095

## White Listello Mix

20x120



Silver Grain White Listello Mix



Silver Grain White Listello Mix Argento \*

## Beige Listello Mix

20x120



Silver Grain Beige Listello Mix



Silver Grain Beige Listello Mix Bronzo \*

## Grey Listello Mix

20x120



Silver Grain Grey Listello Mix



Silver Grain Grey Listello Mix Argento \*

■ 9 mm



Listello Mix  
20x120 cm  
8"x47 1/4"  
(Pcs Box 6)



Listello Mix  
Argento e Bronzo\*  
20x120 cm  
8"x47 1/4"  
(Pcs Box 6)

Mix Superfici / Mix surfaces  
Mix oberflächen / Mix surfaces  
Naturale / Rigato / Bocciaurato

WHITE  
BEIGE  
GREY

SI01EAM ■ 101  
SI02EAM ■ 101  
SI03EAM ■ 101

SI01EAMA ■ 093  
SI02EAMB ■ 093  
SI03EAMA ■ 093



Mix Superfici /  
Mix Surfaces  
20x20

Mix di superfici già miscelate  
all'interno delle scatole, più facili  
da ordinare e pronte all'uso.

Every box contains 1 piece in every  
available finish, to make it easier  
and ready to start tiling.

Das Material wird bereits vermisch  
in die Kartons verpackt, so dass der  
Bestellvorgang durch einsatzbereites  
Material erleichtert wird.

Des surfaces déjà mélangées à  
l'intérieur des emballages, plus  
faciles à ranger et prêts à l'emploi.



\* LISTELLO MIX  
ARGENTO / BRONZO

Si consiglia la posa solo a parete.

Recommended for wall installation  
only.

Es wird die Verlegung nur an Wänden  
empfohlen.

Il est conseillé de poser ces  
plaques uniquement sur les murs.

## Taupe Listello Mix

20x120



Silver Grain Taupe Listello Mix



Silver Grain Taupe Listello Mix Bronzo \*

## Dark Listello Mix

20x120



Silver Grain Dark Listello Mix



Silver Grain Dark Listello Mix Argento \*

■ 9 mm



Listello Mix  
20x120 cm  
8"x47 1/4"  
(Pcs Box 6)



Listello Mix  
Argento e Bronzo\*  
20x120 cm  
8"x47 1/4"  
(Pcs Box 6)



Mix Superfici /  
Mix Surfaces  
20x20



\* LISTELLO MIX  
ARGENTO E  
BRONZO

Mix di superfici già miscelate all'interno delle scatole, più facili da ordinare e pronte all'uso.

Every box contains 1 piece in every available finish, to make it easier and ready to start tiling.

Das Material wird bereits verpackt, so dass der Bestellvorgang durch einsetzbares Material erleichtert wird.

Des surfaces déjà mélangées à l'intérieur des emballages, plus faciles à ranger et prêts à l'emploi.

Si consiglia la posa solo a parete.

Recommended for wall installation only.

Es wird die Verlegung nur an Wänden empfohlen.

Il est conseillé de poser ces plaques uniquement sur les murs.



Taupe Listello Mix Bronzo 20x120

### Mosaico

30x30

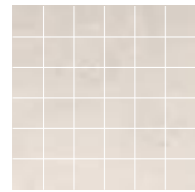

White

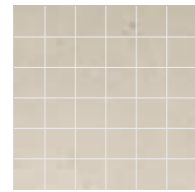

Beige

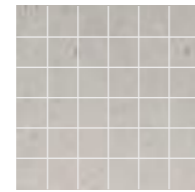

Grey



Taupe

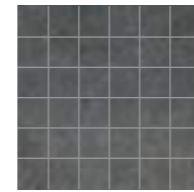

Dark

### Mosaico Chevron Mix

30,5x33



White



Beige



Grey



Taupe



Dark

### Mosaico Esagonetta Mix

30x31



White



Beige



Grey



Taupe



Dark

■ 9 mm - Naturale / Matte - UGL ■ 9 mm - Mix superfici / Mix surface



Mosaico  
30x30 cm  
11<sup>7/8</sup>"x11<sup>7/8</sup>"  
(Pcs Box 12)



Mosaico Chevron Mix  
30,5x33 cm  
12"x13"  
(Pcs Box 6)



Mosaico Esagonetta Mix  
30x31 cm  
11<sup>7/8</sup>"x12<sup>1/4</sup>"  
(Pcs Box 6)

WHITE	SI013MA ■ 137	SI01MCM ■ 036	SI01MESM ■ 052
BEIGE	SI023MA ■ 137	SI02MCM ■ 036	SI02MESM ■ 052
GREY	SI033MA ■ 137	SI03MCM ■ 036	SI03MESM ■ 052
TAUPE	SI043MA ■ 137	SI04MCM ■ 036	SI04MESM ■ 052
DARK	SI053MA ■ 137	SI05MCM ■ 036	SI05MESM ■ 052



Su rete / Mesh mounted



Tessera  
5x5 2"x2"  
Mosaico



Tessera  
3,5x3,5 1<sup>1/2</sup>"x3<sup>3/4</sup>"  
Mosaico Chevron Mix



Tessera  
6x6,5 2<sup>3/8</sup>"x2<sup>5/8</sup>"  
Mosaico Esagonetta Mix



Silver Grain Grey 120x280x0,6, Dark Mosaico Chevron Mix 30,5x33

# Listello

2x120

White Bocciardato / Flamed  
Listello Argentato



Grey Bocciardato / Flamed  
Listello Argentato



Dark Bocciardato / Flamed  
Listello Argentato

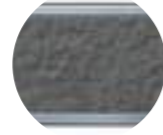

Beige Bocciardato / Flamed  
Listello Bronzo



Taupe Bocciardato / Flamed  
Listello Bronzo



9 mm

Listello Argentato  
2x120 cm  
3/4"x47 1/4"  
(Pcs Box 6)

Listello Bronzo  
2x120 cm  
3/4"x47 1/4"  
(Pcs Box 6)

WHITE	SI01LB1	061
BEIGE	SI02LB2	061
GREY	SI03LB1	061
TAUPE	SI04LB2	061
DARK	SI05LB1	061

## Stucchi consigliati / Recommended grouts

Colori Colors	Silver Grain White	Silver Grain Beige	Silver Grain Grey	Silver Grain Taupe	Silver Grain Dark	Ceppo di Gré Grey
Kerakoll	KK4	KK79	KK68	KK81	KK71	KK68
Mapei	110	110	60% 112 + 40% 110	60% 112 + 40% 130	119	60% 112 + 40% 110

Le tipologie di stucchi riportate nella tabella sono semplici suggerimenti. Prima della posa si raccomanda di eseguire un test di stuccatura per verificarne la compatibilità con la superficie ceramica e le condizioni di utilizzo. / The types of grout listed in the table are simply suggestions. Before installation, it is recommended to perform a grouting test to verify compatibility with the ceramic surface and conditions of use. / Die in der Tabelle aufgeführten Fugenmörteltypen sind lediglich Empfehlungen. Vor dem Verlegen wird empfohlen, einen Fugentest durchzuführen, um die Verträglichkeit mit der Keramikoberfläche und den Einsatzbedingungen zu überprüfen. / Les types de mastics indiqués dans le tableau sont de simples suggestions. Avant la pose, il est recommandé d'effectuer un test de masticage afin de vérifier la compatibilité avec la surface céramique et les conditions d'utilisation.

Pag. 415: approfondimenti calibri specifici / Pag. 415: further information on specific working sizes / S. 415: Vertiefungen über spezifische Werkmaße / Pag. 415 : approfondissements dimensions de fabrication spécifiques

## Pezzi speciali / Special pieces

9 mm

Silver Grain

Battiscopa

7x60 cm  
2 3/4"x23 1/2"  
(Pcs Box 10)

Gradone  
con Toro

120x33x4 cm  
47 1/4"x13"x1 3/4"  
(Pcs Box 2)

Elemento "L"  
Incollato

4,5x16,5x60 cm  
1 3/4"x6 1/2"x23 1/2"  
(Pcs Box 4)

WHITE	Naturale / Matte	SI0176	009	SI01GT2	223	SI0195I	059
BEIGE	Naturale / Matte	SI0276	009	SI02GT2	223	SI0295I	059
GREY	Naturale / Matte	SI0376	009	SI03GT2	223	SI0395I	059
TAUPE	Naturale / Matte	SI0476	009	SI04GT2	223		
DARK	Naturale / Matte	SI0576	009	SI05GT2	223		

## Pezzi speciali / Special pieces

9 mm

Ceppo di Gré

Battiscopa

7x60 cm  
2 3/4"x23 1/2"  
(Pcs Box 10)

Gradone  
con Toro

120x33x4 cm  
47 1/4"x13"x1 3/4"  
(Pcs Box 2)

GREY	Naturale / Matte	CG0176	009	CG01GT2	223
------	------------------	--------	-----	---------	-----



Download Catalogue

## 20 mm Open - Pezzi speciali / Special pieces

Per approfondimenti sui pezzi speciali e tutti gli accessori per esterno 20mm scarica la scheda tecnica oppure consultare il nostro sito e il catalogo Open.

For further information on special pieces and all 20mm outdoor accessories download the technical data sheet or consult our website and the Open catalog.

Für weitere Informationen zu Sonderteilen und dem gesamten 20mm Outdoor Zubehör laden Sie das technische Datenblatt herunter oder besuchen Sie unsere Website und den Open-Katalog.

Pour approfondissements sur les pièces de finition et accessoires pour extérieurs en 20mm merci de télécharger la fiche technique ou bien consulter notre site web et le catalogue OPEN.

## Imballi / Packing

					PCS / BOX	M <sup>2</sup> / BOX	KG / BOX	BOX / PALLET	M <sup>2</sup> / PALLET	KG / PALLET
	120x120 cm - 47 1/4"x47 1/4"	Thick 9 mm	Naturale	PZ / PCS	02	M <sup>2</sup> 2,88	KG 55,34	PZ / PCS 18	M <sup>2</sup> 51,84	KG 1.016,26
	60x120 cm - 23 1/2"x47 1/4"	Thick 9 mm	Naturale	PZ / PCS	02	M <sup>2</sup> 1,44	KG 28,41	PZ / PCS 36	M <sup>2</sup> 51,84	KG 1.043,01
	60x120 cm - 23 1/2"x47 1/4"	(Silver Grain) Thick 9 mm	Antislip	PZ / PCS	02	M <sup>2</sup> 1,44	KG 28,77	PZ / PCS 36	M <sup>2</sup> 51,84	KG 1.056,00
	OPEN 60x120 cm - 23 1/2"x47 1/4"	(Silver Grain) Thick 20 mm	Antislip	PZ / PCS	01	M <sup>2</sup> 0,72	KG 32,20	PZ / PCS 36	M <sup>2</sup> 25,92	KG 1.179,48
	Listello Mix Superfici 20x120 cm - 8"x47 1/4"	(Silver Grain) Thick 9 mm	Mix Superfici	PZ / PCS	06	M <sup>2</sup> 1,44	KG 29,32	PZ / PCS 28	M <sup>2</sup> 40,32	KG 840,98
	80x80 cm - 31 1/2"x31 1/2"	Thick 9 mm	Naturale	PZ / PCS	02	M <sup>2</sup> 1,28	KG 24,88	PZ / PCS 42	M <sup>2</sup> 53,76	KG 1.065,04
	60x60 cm - 23 1/2"x23 1/2"	Thick 9 mm	Naturale	PZ / PCS	04	M <sup>2</sup> 1,44	KG 27,62	PZ / PCS 30	M <sup>2</sup> 43,20	KG 854,66
	OPEN 60x60 cm - 23 1/2"x23 1/2"	(Silver Grain) Thick 20 mm	Antislip	PZ / PCS	02	M <sup>2</sup> 0,72	KG 31,92	PZ / PCS 30	M <sup>2</sup> 21,60	KG 877,48
	30x60 cm - 11 7/8"x23 1/2"	(Silver Grain) Thick 9 mm	Naturale	PZ / PCS	08	M <sup>2</sup> 1,44	KG 27,93	PZ / PCS 32	M <sup>2</sup> 46,08	KG 901,88
	Mosaico 30x30 cm - 11 7/8"x11 7/8"	(Silver Grain) Thick 9 mm	Naturale	PZ / PCS	12	M <sup>2</sup> 1,08	KG 20,62	PZ / PCS 30	M <sup>2</sup> 32,40	KG 638,60
	Mosaico Chevron Mix 30,5x33 cm 12"x13"	(Silver Grain) Thick 9 mm	Mix Superfici	PZ / PCS	06	M <sup>2</sup> 0,60	KG 12,00	PZ / PCS 60	M <sup>2</sup> 36,36	KG 740,00
	Mosaico Esagonetta Mix 30x31 cm 11 7/8"x12 1/4"	(Silver Grain) Thick 9 mm	Mix Superfici	PZ / PCS	06	M <sup>2</sup> 0,55	KG 11,41	PZ / PCS 60	M <sup>2</sup> 33,47	KG 705,08

## Imballi Mega / Mega Packing

	DESCRIZIONE IMBALLO PACKAGING DESCRIPTION	MQ / KG LASTRA / SLAB	IMBALLO PIENO FULL PACKAGING	IMBALLO VUOTO EMPTY PACKAGING
	120x280x0,6 cm 47 1/4"x110 1/4"x1/4"	MQ 3,36	KG 67,20	
		KG 48,60	KG 1062,00	KG 100,00
	CAVALLETTO / A-FRAME L 75 x P 285 x H 153	MQ 3,36	KG 147,84	
		KG 48,60	KG 2318,40	KG 180,00
	CASSA LIGHT / LIGHT CRATE L 145 x P 292 x H 27	MQ 3,36	KG 30,24	
		KG 48,60	KG 527,40	KG 90,00
			PZ 1 / 9	



# Nordic Stone

Gres porcellanato - Rettificato / Porcelain Stoneware - Rectified  
 Feinsteinzeug - Kalibriert / Gres Cerame - Rectifié

Conforming to Standards  
 EN 14411 ISO 13006 APPENDICE G GRUPPO BIa UGL CON Ev ≤ 0,5%



Download  
 Catalogue

Caratteristiche tecniche  
 Technical features

BENDING STRENGTH	FROST RESISTANCE	CHEMICAL RESISTANCE	STAIN RESISTANCE
ANSI A326.3 > 0,42	R11 / A+B+C	TRAFFICO INTENSO HEAVY TRAFFIC	V2 MODERATE
Naturale / Matte Antislip	Antislip	Naturale / Matte Antislip	All Colours

Formati  
 Sizes

	■ 9 mm				
<b>SUPERFICIE SURFACE</b>					
	80x160 cm 31 <sup>1/2</sup> "x63"	60x120 cm 23 <sup>1/2</sup> "x47 <sup>1/4</sup> "	60x60 cm 23 <sup>1/2</sup> "x23 <sup>1/2</sup> "	30x60 cm 11 <sup>7/8</sup> "x23 <sup>1/2</sup> "	30x60 cm 11 <sup>7/8</sup> "x23 <sup>1/2</sup> "
Naturale / Matte	■	■	■	■	■
Antislip					■

Colori  
 Colours

Islanda	Danimarca	Norvegia	Svezia	Finlandia

Superficie  
 Surface finishes

Naturale Matte	Antislip

Islanda 80x160, Mosaico Chevron Islanda 28x32

Islanda



Danimarca



Norvegia



Svezia



Finlandia



		■ 9 mm				
		80x160 cm 31 <sup>1/2</sup> "x63"	60x120 cm 23 <sup>1/2</sup> "x47 <sup>1/4</sup> "	60x60 cm 23 <sup>1/2</sup> "x23 <sup>1/2</sup> "	30x60 cm 11 <sup>7/8</sup> "x23 <sup>1/2</sup> "	Not rectified 30x60 cm 11 <sup>7/8</sup> "x23 <sup>1/2</sup> "
Naturale / Matte	UGL	ISLANDA NT01GA ■ 078	NT01BA ■ 068	NT0168 ■ 052	NT0163 ■ 052	
		DANIMARCA NT02GA ■ 078	NT02BA ■ 068	NT0268 ■ 052	NT0263 ■ 052	
		NORVEGIA NT03GA ■ 078	NT03BA ■ 068	NT0368 ■ 052	NT0363 ■ 052	
		SVEZIA NT04GA ■ 078	NT04BA ■ 068	NT0468 ■ 052	NT0463 ■ 052	
		FINLANDIA NT05GA ■ 078	NT05BA ■ 068	NT0568 ■ 052	NT0563 ■ 052	
Antislip	UGL	ISLANDA				NT0160A ■ 037
		DANIMARCA				NT0260A ■ 037
		NORVEGIA				NT0360A ■ 037
		SVEZIA				NT0460A ■ 037
		FINLANDIA				NT0560A ■ 037

## Mosaico Chevron

28x32



Islanda Danimarca Norvegia Svezia Finlandia

## Mosaico A

30x30

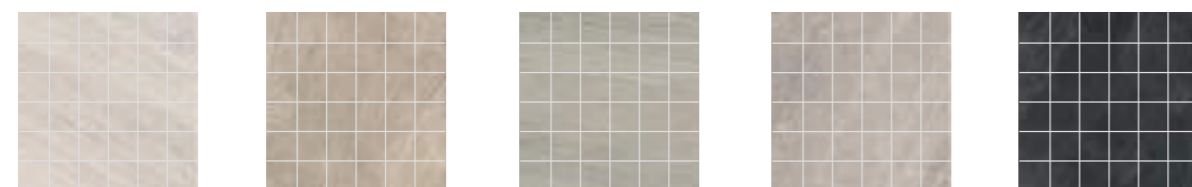

Islanda Danimarca Norvegia Svezia Finlandia

9 mm - Naturale / Matte - UGL

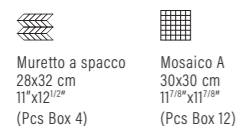

Muretto a spacco  
28x32 cm  
11"x12"  
(Pcs Box 4)

Mosaico A  
30x30 cm  
11 7/8"x11 7/8"  
(Pcs Box 12)

<b>ISLANDA</b>	NT01MC 043	NT013MA 137
<b>DANIMARCA</b>	NT02MC 043	NT023MA 137
<b>NORVEGIA</b>	NT03MC 043	NT033MA 137
<b>SVEZIA</b>	NT04MC 043	NT043MA 137
<b>FINLANDIA</b>	NT05MC 043	NT053MA 137



Su rete / Mesh mounted Mosaico A Mosaico Chevron

## Stucchi consigliati / Recommended grouts

Colori Colors	Islanda	Danimarca	Norvegia	Svezia	Finlandia
<b>Kerakoll</b>	KK4	KK79	KK68	KK69	KK12
<b>Mapei</b>	111	50% 103 + 50% 137	112	113	90% 114 + 10% 120

Le tipologie di stucchi riportate nella tabella sono semplici suggerimenti. Prima della posa si raccomanda di eseguire un test di stuccatura per verificarne la compatibilità con la superficie ceramica e le condizioni di utilizzo. / The types of grout listed in the table are simply suggestions. Before installation, it is recommended to perform a grouting test to verify compatibility with the ceramic surface and conditions of use. / Die in der Tabelle aufgeführten Fugenmörteltypen sind lediglich Empfehlungen. Vor dem Verlegen wird empfohlen, einen Fugentest durchzuführen, um die Verträglichkeit mit der Keramikoberfläche und den Einsatzbedingungen zu überprüfen. / Les types de mastics indiqués dans le tableau sont de simples suggestions. Avant la pose, il est recommandé d'effectuer un test de masticage afin de vérifier la compatibilité avec la surface céramique et les conditions d'utilisation.

## Pezzi speciali / Special pieces

9 mm



Battiscopa  
7x60 cm  
2 3/4"x23 1/2"  
(Pcs Box 10)

Gradone con Toro  
120x33x4 cm  
47 1/8"x13"x1 3/8"  
(Pcs Box 2)

Elemento "L" Incollato  
4,5x16,5x60 cm  
1 3/4"x6 1/2"x23 1/2"  
(Pcs Box 4)

<b>ISLANDA</b>	Naturale / Matte	NT0176 009	NT01GT2 223
	Antislip		NT0195I 059
<b>DANIMARCA</b>	Naturale / Matte	NT0276 009	NT02GT2 223
	Antislip		NT0295I 059
<b>NORVEGIA</b>	Naturale / Matte	NT0376 009	NT03GT2 223
	Antislip		NT0395I 059
<b>SVEZIA</b>	Naturale / Matte	NT0476 009	NT04GT2 223
	Antislip		NT0495I 059
<b>FINLANDIA</b>	Naturale / Matte	NT0576 009	NT05GT2 223
	Antislip		NT0595I 059

## Imballi / Packing



	80x160 cm - 31 1/2"x62 7/8"	60x120 cm - 23 1/2"x47 1/4"	60x60 cm - 23 1/2"x23 1/2"	30x60 cm - 11 7/8"x23 5/8"	Not Rectified 30x60 cm - 11 7/8"x23 1/2"	Mosaico 30x30 cm - 11 7/8"x11 7/8"	Mosaico Chevron 28x32 cm - 11"x12 1/2"
Thick 9 mm	Naturale	Naturale	Naturale	Naturale	Antislip	Naturale	Naturale
PCS / BOX	02	02	04	08	08	12	04
M² / BOX	2,56	1,44	1,44	1,44	1,44	1,08	0,36
KG / BOX	50,58	29,37	28,42	27,81	26,46	21,00	8,60
BOX / PALLET	18	36	30	32	32	30	60
M² / PALLET	46,08	51,84	43,20	46,08	46,08	32,40	21,50
KG / PALLET	930,49	1.041,35	872,78	910,04	867,00	650,00	536,00



Ardesia Black 60x120

# Stone Mix

Gres porcellanato - Rettificato / Porcelain Stoneware - Rectified  
 Feinsteinzeug - Kalibriert / Gres Cerame - Rectifié

Conforming to Standards  
 EN 14411 ISO 13006 APPENDICE G GRUPPO BIa UGL CON Ev ≤ 0,5%



Download  
 Catalogue

## Caratteristiche tecniche Technical features

BENDING STRENGTH	FROST RESISTANCE	CHEMICAL RESISTANCE	STAIN RESISTANCE
ANSI A326.3 > 0,42	R11 / A+B+C	TRAFFICO INTENSO HEAVY TRAFFIC	V3 HIGH
Naturale / Matte Antislip	Antislip	Naturale / Matte Antislip	Stone Mix All Colours

## Formati Sizes

	■ 9 mm
	Not rectified
SUPERFICIE SURFACE	30x60 cm 11 <sup>7/8</sup> "x23 <sup>1/2</sup> "
Naturale / Matte	■
Antislip	■

## Colori Colours

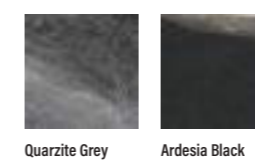

## Superficie Surface finishes



### Quarzite Grey



### Ardesia Black



#### Pezzi speciali / Special pieces

9 mm



Battiscopa

7x60 cm  
2<sup>3/4</sup>"x23<sup>1/2</sup>"  
(Pcs Box 10)



Elemento "L"  
Incollato

4,5x16,5x60 cm  
1<sup>3/4</sup>"x6<sup>1/2</sup>"x23<sup>1/2</sup>"  
(Pcs Box 4)

QUARZITE GREY	Naturale / Matte	TX0474	009
	Antislip	TX0495I	059
ARDESIA BLACK	Naturale / Matte	TX0574	009

#### Imballi / Packing

				PCS / BOX	M <sup>2</sup> / BOX	KG / BOX	BOX / PALLET	M <sup>2</sup> / PALLET	KG / PALLET
Not rectified	30x60 cm - 11 <sup>7/8</sup> "x23 <sup>1/2</sup> "	Thick 9 mm	Naturale						
Not rectified	30x60 cm - 11 <sup>7/8</sup> "x23 <sup>1/2</sup> "	Thick 9 mm	Antislip	PZ / PCS 08	M <sup>2</sup> 1,44	KG 26,25	PZ / PCS 32	M <sup>2</sup> 46,08	KG 860,00
Not rectified	30x60 cm - 11 <sup>7/8</sup> "x23 <sup>1/2</sup> "	Thick 9 mm	Antislip	PZ / PCS 08	M <sup>2</sup> 1,44	KG 25,65	PZ / PCS 32	M <sup>2</sup> 46,08	KG 860,00

9 mm

Not rectified

30x60 cm  
11<sup>7/8</sup>"x23<sup>1/2</sup>"

Naturale / Matte	UGL	QUARZITE GREY	TX0460	037
		ARDESIA BLACK	TX0560	037
Antislip	UGL	QUARZITE GREY	TX0460A	037

#### Stucchi consigliati / Recommended grouts

Colori Colors	Quarzite Grey	Ardesia Black
Kerakoll	KK10	KK12
Mapei	113	114

Le tipologie di stucchi riportate nella tabella sono semplici suggerimenti. Prima della posa si raccomanda di eseguire un test di stuccatura per verificarne la compatibilità con la superficie ceramica e le condizioni di utilizzo. / The types of grout listed in the table are simply suggestions. Before installation, it is recommended to perform a grouting test to verify compatibility with the ceramic surface and conditions of use. / Die in der Tabelle aufgeführten Fugenmörteltypen sind lediglich Empfehlungen. Vor dem Verlegen wird empfohlen, einen Fugentest durchzuführen, um die Verträglichkeit mit der Keramikoberfläche und den Einsatzbedingungen zu überprüfen. / Les types de mastics indiqués dans le tableau sont de simples suggestions. Avant la pose, il est recommandé d'effectuer un test de masticage afin de vérifier la compatibilité avec la surface céramique et les conditions d'utilisation.

Pag. 415: approfondimenti calibri specifici / Pag. 415: further information on specific working sizes / S. 415: Vertiefungen über spezifische Werkmaße / Pag. 415 : approfondissements dimensions de fabrication spécifiques

**218 Concrete & Metal Effect**

220 | Cementi

244 | Terre

260 | Metaline



Flax 120x280x0,6, Muretto 30x30, Taupe 120x280x0,6, Muretto 30x30

# I Cementi

Gres porcellanato - Rettificato / Porcelain Stoneware - Rectified  
Feinsteinzeug - Kalibriert / Gres Cerame - Rectifié

Conforming to Standards  
EN 14411 ISO 13006 APPENDICE G GRUPPO BIa UGL CON  $E_v \leq 0,5\%$

New Innovative  
Technology

RealUp®  
StrideUp®



Download  
Catalogue

Caratteristiche tecniche  
Technical features

BENDING STRENGTH	FROST RESISTANCE	CHEMICAL RESISTANCE	STAIN RESISTANCE	
ANSI A326.3 > 0,42	R10 / A +B	R11 / A+B+C	TRAFFICO INTENSO HEAVY TRAFFIC	V2 MODERATE
Naturale / Matte RealUp + StrideUp Antislip OPEN	RealUp + StrideUp	Antislip OPEN	Naturale / Matte RealUp / StrideUp Antislip OPEN	All Colours

Formati  
Sizes

<b>SUPERFICIE SURFACE</b>	120x280x0,6 cm 47 <sup>1/4</sup> "x110 <sup>3/8</sup> "x1/4"	120x120 cm 47 <sup>1/4</sup> "x47 <sup>1/4</sup> "	60x120 cm 23 <sup>1/2</sup> "x47 <sup>1/4</sup> "	80x80 cm 31 <sup>1/2</sup> "x31 <sup>1/2</sup> "	60x60 cm 23 <sup>1/2</sup> "x23 <sup>1/2</sup> "	30x60 cm 11 <sup>1/8</sup> "x23 <sup>1/2</sup> "	60x120 cm 23 <sup>1/2</sup> "x47 <sup>1/4</sup> "	60x60 cm 23 <sup>1/2</sup> "x23 <sup>1/2</sup> "
Naturale / Matte Natur / Naturel	■							
RealUp + StrideUp	■	■	■	■	■	■	■	
Antislip		■ <small>new</small>	■				■	

Colori  
Colours

White	Beige	Ivory	Argil	Flax	Taupe	Moka	Greige	Grey
Dark	Black							
Ivory Ciottolo	Flax Ciottolo	Argil Ciottolo	White Ciottolo	Greige Ciottolo				

Superficie  
Surface finishes

Naturale Matte	RealUp + StrideUp	Antislip



I Cementi Ivory 120x280x0,6, Natural Flax listello Tratto 20x120



Ivory 120x280x0,6, Argil 120x120



Ivory 120x280x0,6, Ciottolo Ivory 120x120, Mosaico Argil 30x30



Greige 120x280x0,6, Muretto Dark 30x30, Greige Ciottolo 120x120

White

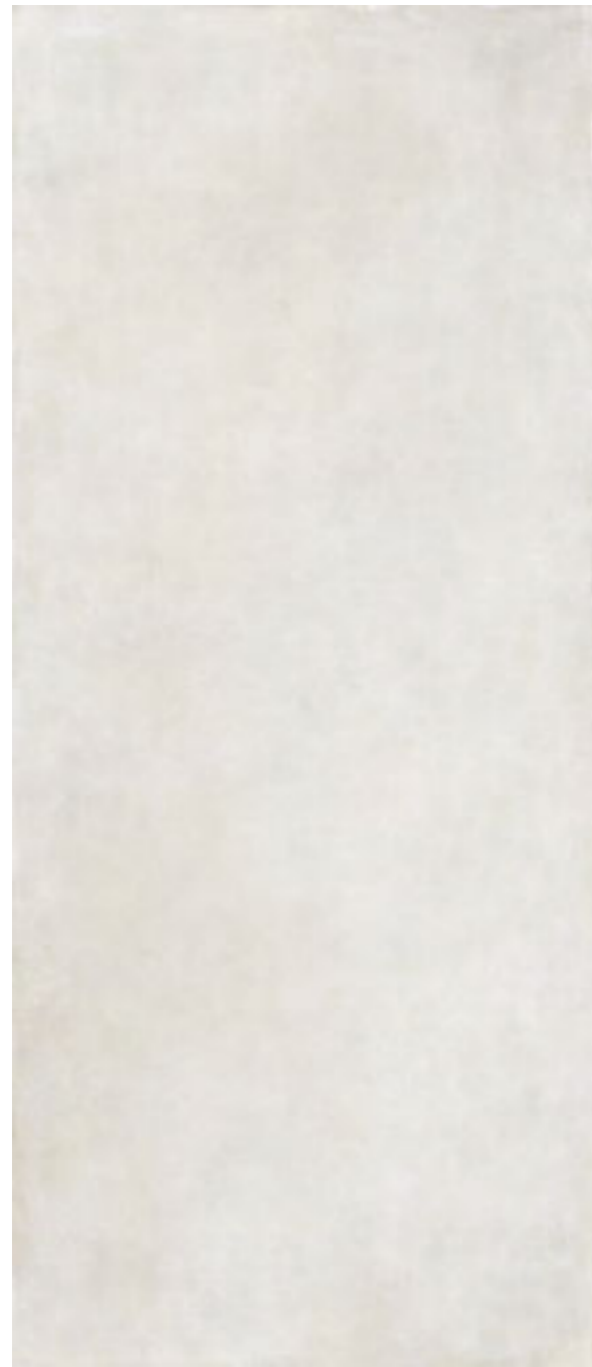

Beige



new

Ivory

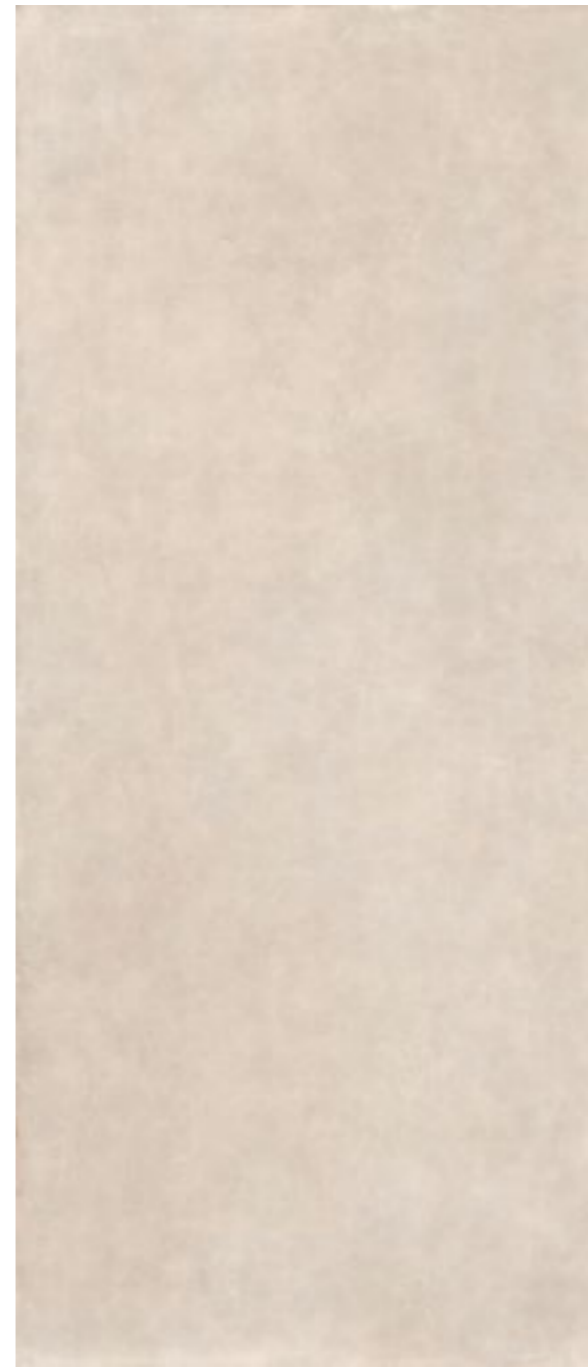

new

Argil



6 mm 9 mm - RealUp + StrideUp

		120x280x0,6 cm 47 1/4" x 110 1/4" x 1/4"	120x120 cm 47 1/4" x 47 1/4"	60x120 cm 23 1/2" x 47 1/4"	80x80 cm 31 1/2" x 31 1/2"	60x60 cm 23 1/2" x 23 1/2"	30x60 cm 11 7/8" x 23 1/2"
Naturale / Matte	UGL	WHITE FL01XPA ■ 110					
		BEIGE FL02XPA ■ 110					
RealUp / StrideUp	UGL	WHITE	FL0112 ■ 078	FL01BA ■ 068	FL0188 ■ 062	FL0168 ■ 052	FL0163 ■ 052
		BEIGE	FL0212 ■ 078	FL02BA ■ 068	FL0288 ■ 062	FL0268 ■ 052	FL0263 ■ 052
Antislip	UGL	WHITE		FL01BAA ■ 068			
		BEIGE	FL0212A ■ 078	FL02BAA ■ 068			

6 mm 9 mm - RealUp + StrideUp

		120x280x0,6 cm 47 1/4" x 110 1/4" x 1/4"	120x120 cm 47 1/4" x 47 1/4"	60x120 cm 23 1/2" x 47 1/4"	80x80 cm 31 1/2" x 31 1/2"	60x60 cm 23 1/2" x 23 1/2"	30x60 cm 11 7/8" x 23 1/2"
Naturale / Matte	UGL	IVORY FL08XPA ■ 110					
		ARGIL FL09XPA ■ 110					
RealUp / StrideUp	UGL	IVORY	FL0812 ■ 078	FL08BA ■ 068	FL0888 ■ 062	FL0868 ■ 052	FL0863 ■ 052
		ARGIL	FL0912 ■ 078	FL09BA ■ 068	FL0988 ■ 062	FL0968 ■ 052	FL0963 ■ 052
Antislip	UGL	IVORY		FL08BAA ■ 068			
		ARGIL	FL0912A ■ 078	FL09BAA ■ 068			

Flax



Taupe

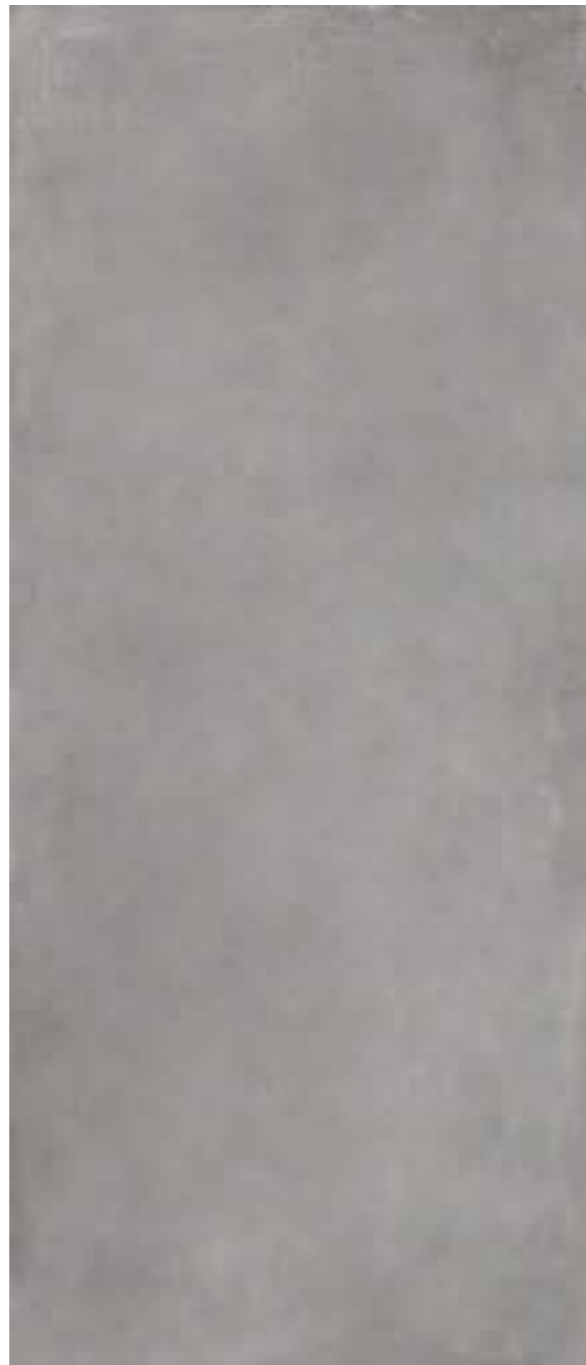

new  
Moka

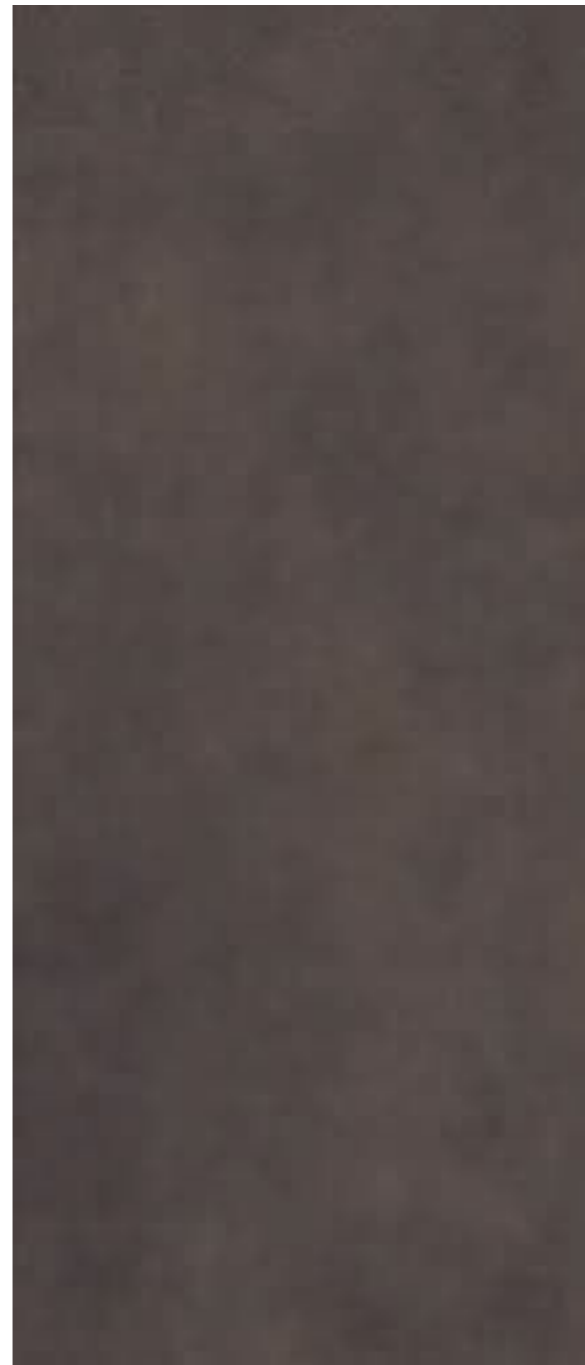

6 mm    9 mm - RealUp + StrideUp    20 mm - OPEN

		120x280x0,6 cm 47 <sup>11/16</sup> "x110 <sup>11/16</sup> "x1/4"	120x120 cm 47 <sup>11/16</sup> "x47 <sup>11/16</sup> "	60x120 cm 23 <sup>1/2</sup> "x47 <sup>11/16</sup> "	80x80 cm 31 <sup>1/2</sup> "x31 <sup>1/2</sup> "	60x60 cm 23 <sup>1/2</sup> "x23 <sup>1/2</sup> "	30x60 cm 11 <sup>7/8</sup> "x23 <sup>1/2</sup> "	60x120 cm 23 <sup>1/2</sup> "x47 <sup>11/16</sup> "	60x60 cm 23 <sup>1/2</sup> "x23 <sup>1/2</sup> "
Naturale / Matte	UGL	FLAX FL03XPA ■ 110							
	UGL	TAUPE FL04XPA ■ 110							
RealUp / StrideUp	UGL	FLAX	FL0312 ■ 078	FL03BA ■ 068	FL0388 ■ 062	FL0368 ■ 052	FL0363 ■ 052		
	UGL	TAUPE	FL0412 ■ 078	FL04BA ■ 068	FL0488 ■ 062	FL0468 ■ 052	FL0463 ■ 052		
Antislip	UGL	FLAX		FL03BAA ■ 068				FL03BA2 ■ 095	FL03682 ■ 075
	UGL	TAUPE		FL04BAA ■ 068				FL04BA2 ■ 095	FL04682 ■ 075

6 mm    9 mm - RealUp + StrideUp

		120x280x0,6 cm 47 <sup>11/16</sup> "x110 <sup>11/16</sup> "x1/4"	120x120 cm 47 <sup>11/16</sup> "x47 <sup>11/16</sup> "	60x120 cm 23 <sup>1/2</sup> "x47 <sup>11/16</sup> "	80x80 cm 31 <sup>1/2</sup> "x31 <sup>1/2</sup> "	60x60 cm 23 <sup>1/2</sup> "x23 <sup>1/2</sup> "	30x60 cm 11 <sup>7/8</sup> "x23 <sup>1/2</sup> "
Naturale / Matte	UGL	MOKA FL10XPA ■ 110					
RealUp / StrideUp	UGL	MOKA	FL1012 ■ 078	FL10BA ■ 068	FL1088 ■ 062	FL1068 ■ 052	FL1063 ■ 052

Greige



Grey



Dark

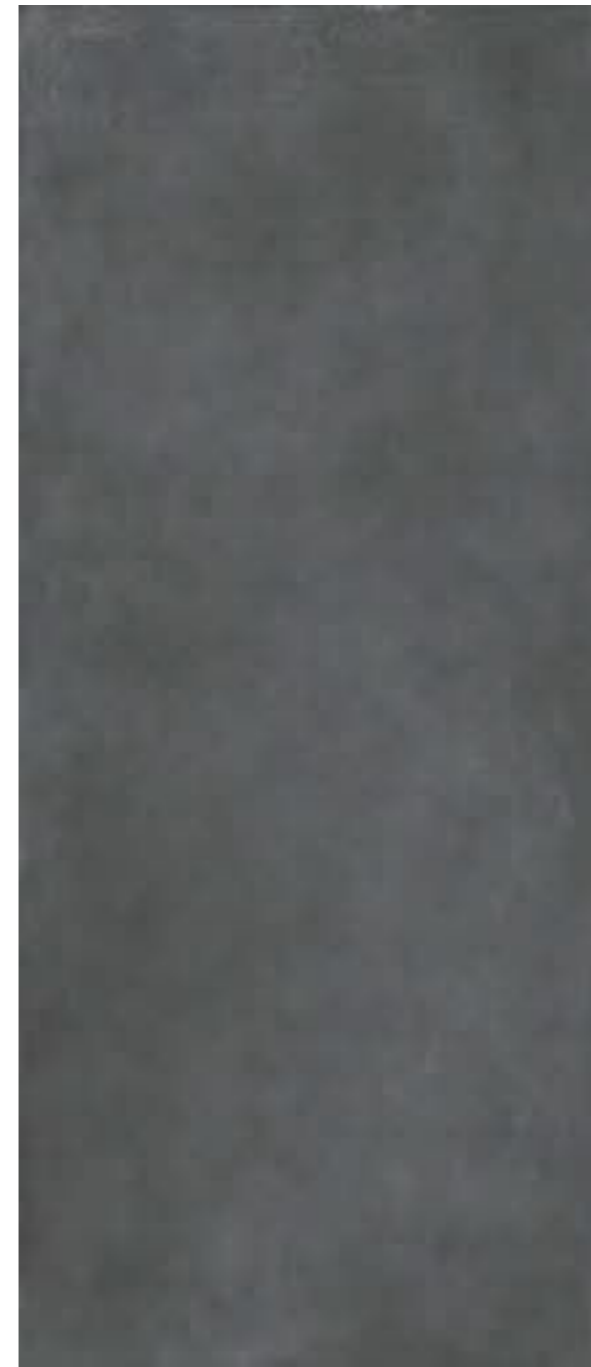

Black new



		6 mm		9 mm - RealUp + StrideUp						20 mm - OPEN	
		120x280x0,6 cm 47 <sup>1/4</sup> "x110 <sup>1/4</sup> "x1/4"	120x120 cm 47 <sup>1/4</sup> "x47 <sup>1/4</sup> "	60x120 cm 23 <sup>1/2</sup> "x47 <sup>1/4</sup> "	80x80 cm 31 <sup>1/2</sup> "x31 <sup>1/2</sup> "	60x60 cm 23 <sup>1/2</sup> "x23 <sup>1/2</sup> "	30x60 cm 11 <sup>7/8</sup> "x23 <sup>1/2</sup> "	60x120 cm 23 <sup>1/2</sup> "x47 <sup>1/4</sup> "	60x60 cm 23 <sup>1/2</sup> "x23 <sup>1/2</sup> "		
Naturale / Matte	UGL	GREIGE FL05XPA ■ 110									
		GREY FL06XPA ■ 110									
RealUp / StrideUp	UGL	GREIGE	FL0512 ■ 078	FL05BA ■ 068	FL0588 ■ 062	FL0568 ■ 052	FL0563 ■ 052				
		GREY	FL0612 ■ 078	FL06BA ■ 068	FL0688 ■ 062	FL0668 ■ 052	FL0663 ■ 052				
Antislip	UGL	GREIGE		FL05BAA ■ 068							
		GREY		FL06BAA ■ 068				FL06BA2 ■ 095	FL06682 ■ 075		

		6 mm		9 mm - RealUp + StrideUp							
		120x280x0,6 cm 47 <sup>1/4</sup> "x110 <sup>1/4</sup> "x1/4"	120x120 cm 47 <sup>1/4</sup> "x47 <sup>1/4</sup> "	60x120 cm 23 <sup>1/2</sup> "x47 <sup>1/4</sup> "	80x80 cm 31 <sup>1/2</sup> "x31 <sup>1/2</sup> "	60x60 cm 23 <sup>1/2</sup> "x23 <sup>1/2</sup> "	30x60 cm 11 <sup>7/8</sup> "x23 <sup>1/2</sup> "				
Naturale / Matte	UGL	DARK FL07XPA ■ 110									
		BLACK FL11XPA ■ 110									
RealUp / StrideUp	UGL	DARK	FL0712 ■ 078	FL07BA ■ 068	FL0788 ■ 062	FL0768 ■ 052	FL0763 ■ 052				
		BLACK	FL1112 ■ 078	FL11BA ■ 068	FL1188 ■ 062	FL1168 ■ 052	FL1163 ■ 052				

new  
Ciottolo

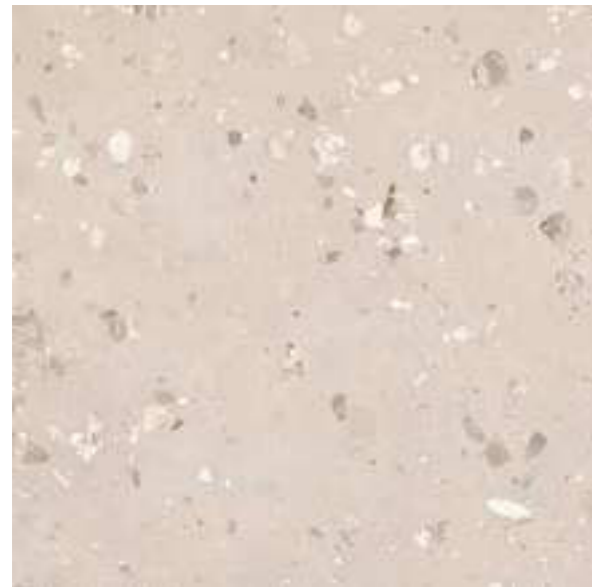

Ivory Ciottolo



Flax Ciottolo

new

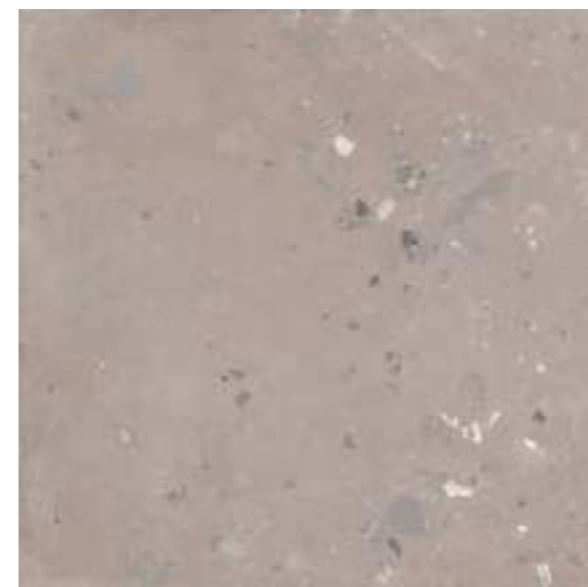

Argil Ciottolo



White Ciottolo

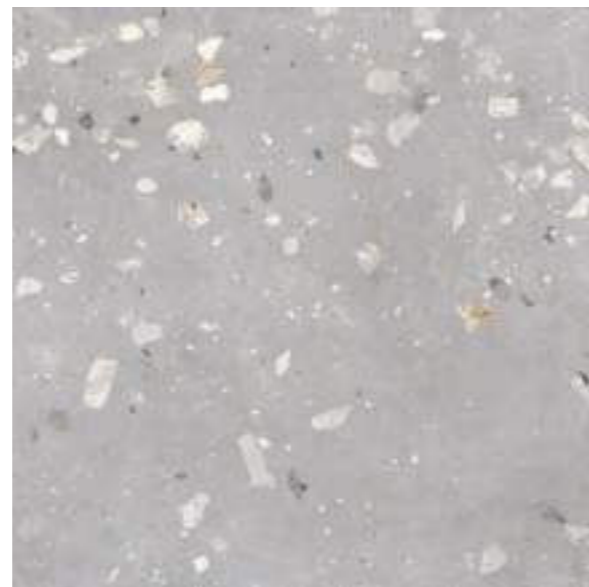



Greige Ciottolo



Listello Beige 20x120, White Ciottolo 60x120

■ 9 mm - RealUp + StrideUp - UGL

	
Ciottolo 120x120 cm 47 <sup>1/4</sup> "x47 <sup>1/4</sup> "	Ciottolo 60x120 cm 23 <sup>1/2</sup> "x47 <sup>1/4</sup> "

<b>WHITE</b>	FL0112C	090	FL01BAC	080
<b>IVORY</b>	FL0812C	090	FL08BAC	080
<b>ARGIL</b>	FL0912C	090	FL09BAC	080
<b>FLAX</b>	FL0312C	090	FL03BAC	080
<b>GREIGE</b>	FL0512C	090	FL05BAC	080

# Decoro Lito 3D

Design Andrea Parisio & Giuseppe Pezzano



White

Beige

Ivory

Argil

Flax



Taupe

Moka

Greige

Grey

Dark

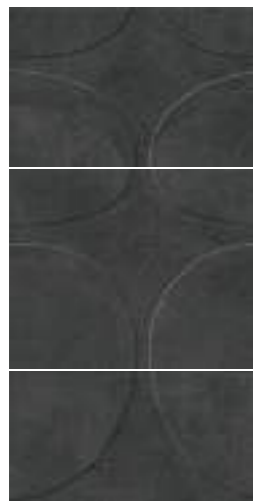

Black

9 mm  
RealUp + StrideUp - UGL



Decoro Lito 3D  
60x120  
23<sup>1/2</sup>"x47<sup>1/4</sup>"  
(Pcs Box 3)

WHITE	FL01DLT	521
BEIGE	FL02DLT	521
IVORY	FL08DLT	521
ARGIL	FL09DLT	521
FLAX	FL03DLT	521
TAUPE	FL04DLT	521
MOKA	FL10DLT	521
GREIGE	FL05DLT	521
GREY	FL06DLT	521
DARK	FL11DLT	521
BLACK	FL07DLT	521

Decoro Lito 3D



38x60 cm 15"x23<sup>1/2</sup>"



50x60 cm 11<sup>11/16</sup>"x23<sup>1/2</sup>"



32x60 cm 12<sup>5/8</sup>"x23<sup>1/2</sup>"

## Schemi di posa / Installation systems



# Decoro Lito 3D

Design Andrea Parisio & Giuseppe Pezzano

Studiato dagli architetti Andrea Parisio e Giuseppe Pezzano, è un decoro organico dalla profondità tridimensionale. La forma piacevolmente irregolare evoca una bellezza archetipica, creando pattern di grande effetto. Il decoro è declinato in tutti i colori della serie I Cementi.

Ogni scatola viene venduta contenente 3 pezzi che formano una composizione 60x120 cm.

Designed by the architects Andrea Parisio and Giuseppe Pezzano, it is an integrated decoration with three-dimensional depth. The pleasingly irregular shape evokes archetypal beauty, creating striking patterns. The decor is proposed in all colors of the I Cement collection.

Each box is sold containing 3 pieces that form a composition 60x120 cm.

Diese von den Architekten Andrea Parisio und Giuseppe Pezzano entworfene organische Dekoration zeigt sich mit einer dreidimensionalen Tiefe. Die absichtlich unregelmäßige Form erinnert an eine archetypische Perfektion und schafft sich auffällige Muster. Die Dekoration ist in allen Farben der Serie I Cementi erhältlich.

Jeder Verkaufskarton enthält 3 Platten, die eine 60x120 cm große Komposition bilden.

Développée par les architectes Andrea Parisio et Giuseppe Pezzano, c'est une décoration organique offrant une profondeur tridimensionnelle. La forme agréablement irrégulière évoque une beauté archétypale donnant naissance à des formes à fort effet visuel. La décoration est déclinée dans toutes les couleurs de la collection I Cementi.

Chaque boîte contient 3 pièces qui forment une composition de 60x120 cm.

## Listello Tratto

20x120



White Beige Ivory Argil Flax Taupe Moka



Greige Grey Dark Black

6 mm - Naturale / Matte - UGL

9 mm - RealUp + StrideUp - UGL



Listello Tratto  
20x120 cm  
8"x47 1/4"  
(Pcs Box 6)

Muretto  
30x30 cm  
11 7/8"x11 7/8"  
(Pcs Box 6)

Muretto  
30x30 cm  
11 7/8"x11 7/8"  
(Pcs Box 6)

Mosaico  
30x30 cm  
11 7/8"x11 7/8"  
(Pcs Box 12)

<b>WHITE</b>	FL01LT 098	FL01MB 043	FL01MB9 027	FL013MA 137
<b>BEIGE</b>	FL02LT 098	FL02MB 043	FL02MB9 027	FL023MA 137
<b>IVORY</b>	FL08LT 098	FL08MB 043	FL08MB9 027	FL083MA 137
<b>ARGIL</b>	FL09LT 098	FL09MB 043	FL09MB9 027	FL093MA 137
<b>FLAX</b>	FL03LT 098	FL03MB 043	FL03MB9 027	FL033MA 137
<b>TAUPE</b>	FL04LT 098	FL04MB 043	FL04MB9 027	FL043MA 137
<b>MOKA</b>	FL10LT 098	FL10MB 043	FL10MB9 027	FL103MA 137
<b>GREIGE</b>	FL05LT 098	FL05MB 043	FL05MB9 027	FL053MA 137
<b>GREY</b>	FL06LT 098	FL06MB 043	FL06MB9 027	FL063MA 137
<b>DARK</b>	FL07LT 098	FL07MB 043	FL07MB9 027	FL073MA 137
<b>BLACK</b>	FL11LT 098	FL11MB 043	FL11MB9 027	FL113MA 137

## Muretto

30x30



White Beige Ivory Argil



Flax Taupe Moka Greige



Grey Dark Black

## Mosaico

30x30



White Beige Ivory Argil



Flax Taupe Moka Greige



Grey Dark Black



Su rete / Mesh mounted



Tessera  
2,5x120 1"x47 1/4"



Tessera  
2,8x9,8 1 1/8"x3 7/8"



Tessera  
5x5 2"x2"

Pezzi speciali / Special pieces

**9 mm**

Color	RealUp + StrideUp	Antislip
WHITE	FL01BT7 018	FL0176 009
BEIGE	FL02BT7 018	FL0276 009
IVORY	FL08BT7 018	FL0876 009
ARGIL	FL09BT7 018	FL0976 009
FLAX	FL03BT7 018	FL0376 009
TAUPE	FL04BT7 018	FL0476 009
MOKA	FL10BT7 018	FL1076 009
GREIGE	FL05BT7 018	FL0576 009
GREY	FL06BT7 018	FL0676 009
DARK	FL07BT7 018	FL0776 009
BLACK	FL11BT7 018	FL1176 009



20 mm Open - Pezzi speciali / Special pieces

Per approfondimenti sui pezzi speciali e tutti gli accessori per esterno 20mm scarica la scheda tecnica oppure consultare il nostro sito e il catalogo Open. / For further information on special pieces and all 20mm outdoor accessories download the technical data sheet or consult our website and the Open catalog. / Für weitere Informationen zu Sonderteilen und dem gesamten 20mm Outdoor-Zubehör laden Sie das technische Datenblatt herunter oder besuchen Sie unsere Website und den Open Katalog. / Pour approfondissements sur les pièces de finition et accessoires pour extérieurs en 20mm merci de télécharger la fiche technique ou bien consulter notre site web et le catalogue OPEN.



White 120x280x0,6, Listello Tratto, Flax 60x120

Imballi / Packing

	PCS / BOX	M <sup>2</sup> / BOX	KG / BOX	BOX / PALLET	M <sup>2</sup> / PALLET	KG / PALLET
120x120 cm - 47 <sup>1/4</sup> x47 <sup>1/4</sup> "	2	2,88	59,15	18	51,84	1.084,79
120x120 cm - 47 <sup>1/4</sup> x47 <sup>1/4</sup> " CIOTTOLO	2	2,88	57,63	18	51,84	1.057,37
60x120 cm - 23 <sup>1/2</sup> x47 <sup>1/4</sup> "	2	1,44	29,11	36	51,84	1.068,10
60x120 cm - 23 <sup>1/2</sup> x47 <sup>1/4</sup> "	2	1,44	28,64	36	51,84	1.051,11
60x120 cm - 23 <sup>1/2</sup> x47 <sup>1/4</sup> " CIOTTOLO	2	1,44	28,97	36	51,84	1.062,95
80x80 cm - 31 <sup>1/2</sup> x31 <sup>1/2</sup> "	2	1,28	25,33	42	53,76	1.084,02
OPEN 60x120 cm - 23 <sup>1/2</sup> x47 <sup>1/4</sup> "	1	0,72	32,08	36	25,92	1.175,13
60x60 cm - 23 <sup>1/2</sup> x23 <sup>1/2</sup> "	4	1,44	27,86	30	43,20	855,83
OPEN 60x60 cm - 23 <sup>1/2</sup> x23 <sup>1/2</sup> "	2	0,72	32,17	30	21,60	985,16
30x60 cm - 11 <sup>7/8</sup> x23 <sup>1/2</sup> "	8	1,44	28,40	32	46,08	928,92
Decoro Lito 3D 60x120 cm - 23 <sup>1/2</sup> x47 <sup>1/4</sup> "	3	0,72	15,06	22	15,83	351,32
Listello Tratto 20x120 cm - 8"x47 <sup>1/4</sup> "	6	1,44	19,48	30	43,20	604,46
Muretto 30x30 cm - 11 <sup>7/8</sup> x11 <sup>7/8</sup> "	6	0,54	7,8	60	32,40	489,08
Muretto 30x30 cm - 11 <sup>7/8</sup> x11 <sup>7/8</sup> "	6	0,54	10,45	60	32,40	647,48
Mosaico 30x30 cm - 11 <sup>7/8</sup> x11 <sup>7/8</sup> "	12	1,08	20,62	30	32,40	638,60

Imballi Mega / Mega Packing

	DESCRIZIONE IMBALLO / PACKAGING DESCRIPTION	MQ / KG / LASTRA / SLAB	IMBALLO PIENO / FULL PACKAGING	IMBALLO VUOTO / EMPTY PACKAGING
120x280x0,6 cm 47 <sup>1/4</sup> x110 <sup>1/4</sup> x11/4"	CASSA / CRATE L 145 x P 292 x H 35	MQ 3,36 KG 48,60	MQ 67,20 KG 1062,00	KG 100,00
	CAVALLETTO / A-FRAME L 75 x P 285 x H 153	MQ 3,36 KG 48,60	MQ 147,84 KG 2318,40	KG 180,00
120x280x0,6 cm 47 <sup>1/4</sup> x110 <sup>1/4</sup> x11/4"	CASSA LIGHT / LIGHT CRATE L 145 x P 292 x H 27	MQ 3,36 KG 48,60	MQ 30,24 KG 527,40	KG 90,00

Stucchi consigliati / Recommended grouts

Colori / Colors	White	Beige	Ivory	Argil	Flax	Taupe	Moka	Greige	Grey	Dark	Black
Kerakoll	KK4	KK64	KK79	KK81	KK79	KK69	KK158	KK68	KK8	KK10	KK12
Mapei	111	111	80% 111 + 20% 100	50% 110 + 50% 134	111	60% 110 + 40% 113	30% 100 + 70% 114	60% 100 + 40% 112	40% 100 + 60% 112	50% 110 + 50% 134	30% 100 + 70% 114

Le tipologie di stucchi riportate nella tabella sono semplici suggerimenti. Prima della posa si raccomanda di eseguire un test di stuccatura per verificarne la compatibilità con la superficie ceramica e le condizioni di utilizzo. / The types of grout listed in the table are simply suggestions. Before installation, it is recommended to perform a grouting test to verify compatibility with the ceramic surface and conditions of use. / Die in der Tabelle aufgeführten Fugenmörteltypen sind lediglich Empfehlungen. Vor dem Verlegen wird empfohlen, einen Fugentest durchzuführen, um die Verträglichkeit mit der Keramikoberfläche und den Einsatzbedingungen zu überprüfen. / Les types de mastics indiqués dans le tableau sont de simples suggestions. Avant la pose, il est recommandé d'effectuer un test de masticage afin de vérifier la compatibilité avec la surface céramique et les conditions d'utilisation.

Pag. 415: approfondimenti calibri specifici / Pag. 415: further information on specific working sizes / S. 415: Vertiefungen über spezifische Werkmaße / Pag. 415: approfondissements dimensions de fabrication spécifiques



Senape, Avorio 120x120

# Terre

Gres porcellanato - Rettificato / Porcelain Stoneware - Rectified  
 Feinsteinzeug - Kalibriert / Gres Cerame - Rectifié

New Innovative  
 Technology

StrideUp®



Download  
 Catalogue

Conforming to Standards  
 EN 14411 ISO 13006 APPENDICE G GRUPPO BIa UGL CON Ev ≤ 0,5%

Caratteristiche tecniche  
 Technical features

BENDING STRENGTH	FROST RESISTANCE	CHEMICAL RESISTANCE	STAIN RESISTANCE	
ANSI A326.3 > 0,42	R10 / A + B	R11 / A+B+C	TRAFFICO INTENSO HEAVY TRAFFIC	V2 MODERATE
StrideUp Antislip OPEN	StrideUp	Antislip OPEN	StrideUp Antislip OPEN	All Colours

Formati  
 Sizes

	■ 9 mm - StrideUp					■ 20 mm - OPEN
SUPERFICIE SURFACE	120x120 cm 47 <sup>1/4</sup> "x47 <sup>1/4</sup> "	60x120 cm 23 <sup>1/2</sup> "x47 <sup>1/4</sup> "	80x80 cm 31 <sup>1/2</sup> "x31 <sup>1/2</sup> "	60x60 cm 23 <sup>1/2</sup> "x23 <sup>1/2</sup> "	30x60 cm 11 <sup>7/8</sup> "x23 <sup>1/2</sup> "	60x120 cm 23 <sup>1/2</sup> "x47 <sup>1/4</sup> "
StrideUp	■	■	■	■	■	
Antislip		■				■

Colori  
 Colours

Bianco	Avorio	Canapa	Senape	Cotto	Cenere

Superficie  
 Surface finishes

StrideUp	Antislip



Mini Irregolo Bianco 60x120, Senape, Bianco 120x120



Mini Irregolo Cotto, Cotto 60x120, Canapa 120x120



Cotto



Cotto Irregolo

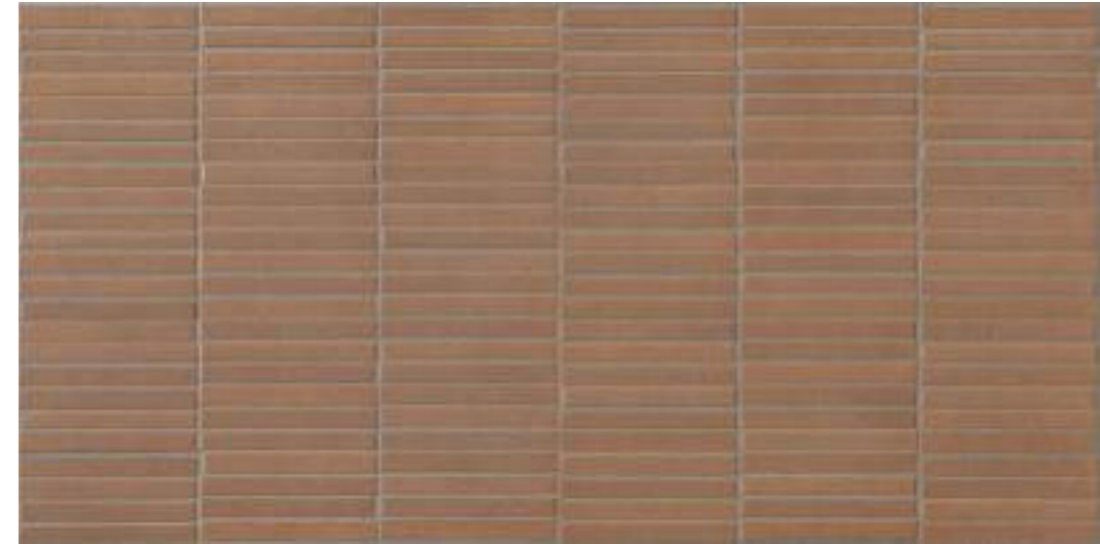

Cotto Bricco

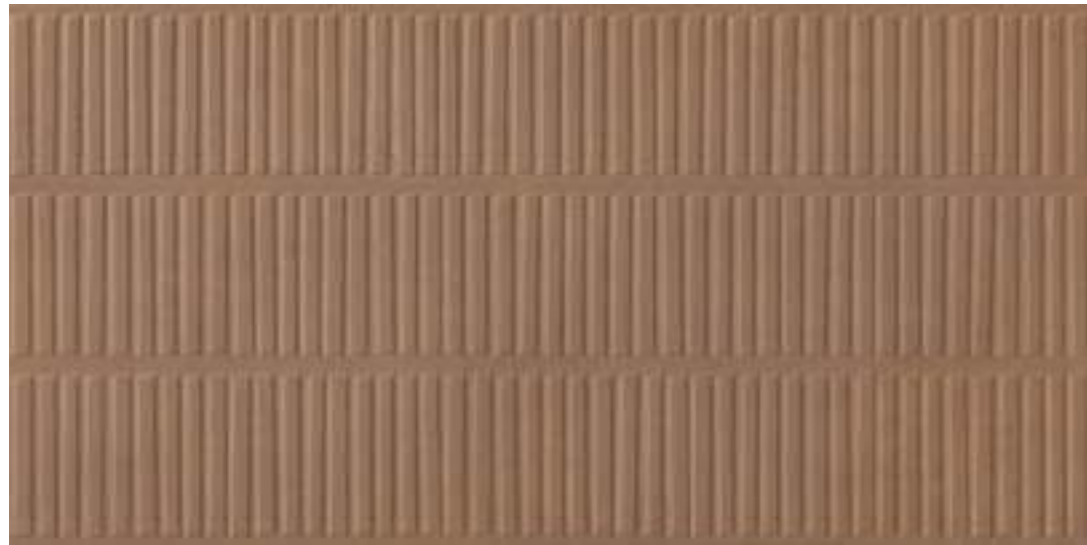

Cotto Mini Irregolo

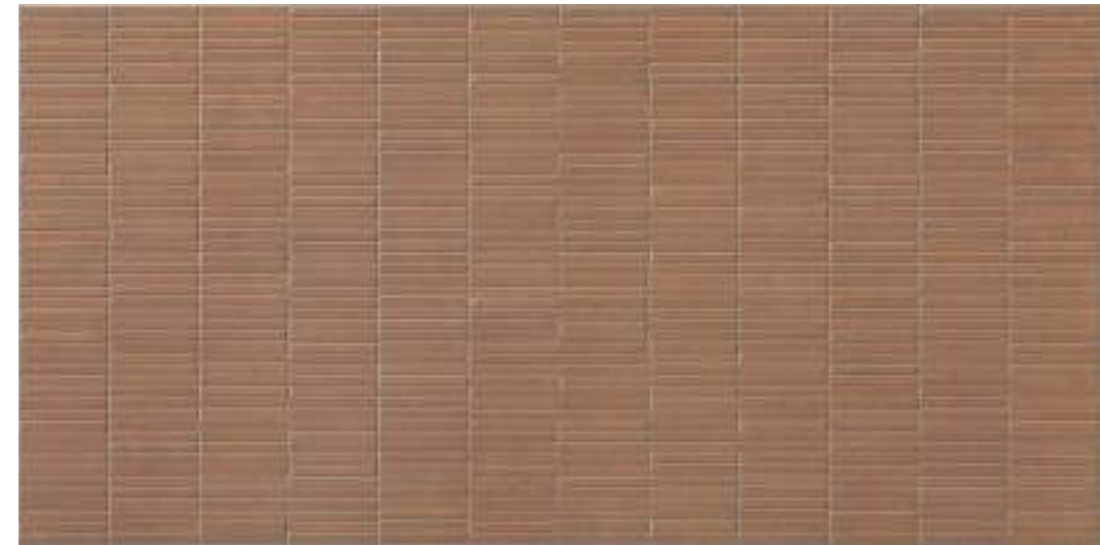

9 mm - StrideUp

		120x120 cm 47 <sup>1/4</sup> "x47 <sup>1/4</sup> "	60x120 cm 23 <sup>1/2</sup> "x47 <sup>1/4</sup> "	80x80 cm 31 <sup>1/2</sup> "x31 <sup>1/2</sup> "	60x60 cm 23 <sup>1/2</sup> "x23 <sup>1/2</sup> "	30x60 cm 11 <sup>7/8</sup> "x23 <sup>1/2</sup> "
<b>StrideUp</b>	<b>UGL</b>	TE0512 ■ 078	TE05BA ■ 068	TE0588 ■ 062	TE0568 ■ 052	TE0563 ■ 052
<b>Antislip</b>	<b>UGL</b>		TE05BAA ■ 068			
<b>Bricco</b>	<b>UGL</b>		TE05BABR ■ 080			
<b>Irregolo</b>	<b>UGL</b>		TE05BAIR ■ 080			
<b>Mini Irregolo</b>	<b>UGL</b>		TE05BAMI ■ 080			



Caratteristiche bordi Bricco, Irregolo, Mini Irregolo. Eventuali disomogeneità dei bordi perimetrali nei moduli Bricco, Irregolo e Mini Irregolo sono da considerarsi non come difetto, ma come caratteristiche del prodotto che, esattamente come accade per i materiali artigianali, possono variare da una produzione all'altra.

Edge features Bricco, Irregolo and Mini Irregolo. Any lack of homogeneity in the perimeter edges of the Bricco, Irregolo and Mini modules should not be considered as defects, but as distinguishing features of the product which, as is the case for craft-based materials, may vary from one product batch to the next.

Eigenschaften der Kanten Bricco, Irregolo und Mini Irregolo. Eventuelle Unregelmäßigkeiten der Kanten bei den Modulen Bricco, Irregolo und Mini Irregolo sind kein Mangel, sondern eine typische Eigenschaft des Produkts, die, genau wie bei handwerklichen Materialien, von einer Produktion zur anderen variieren können.

Caractéristiques des bords Bricco, Irregolo et Mini Irregolo. Les éventuelles irrégularités des bords des modules Bricco, Irregolo et Mini Irregolo sont à considérer non comme des défauts mais comme des caractéristiques du produit qui, exactement comme sur les matériaux de fabrication artisanale, peuvent varier d'une production à l'autre.



Bianco



Bianco Irregolo



Bianco Bricco

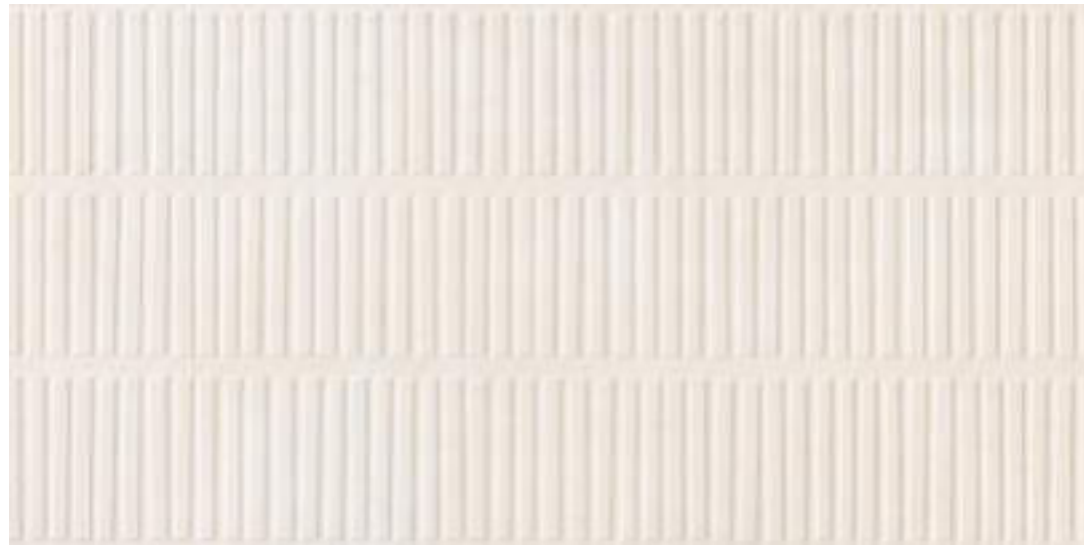

Bianco Mini Irregolo



		■ 9 mm - StrideUp					■ 20 mm - OPEN
		120x120 cm 47 <sup>1/4</sup> "x47 <sup>1/4</sup> "	60x120 cm 23 <sup>1/2</sup> "x47 <sup>1/4</sup> "	80x80 cm 31 <sup>1/2</sup> "x31 <sup>1/2</sup> "	60x60 cm 23 <sup>1/2</sup> "x23 <sup>1/2</sup> "	30x60 cm 11 <sup>7/8</sup> "x23 <sup>1/2</sup> "	60x120 cm 23 <sup>1/2</sup> "x47 <sup>1/4</sup> "
<b>StrideUp</b>	UGL	TE0112 ■ 078	TE01BA ■ 068	TE0188 ■ 062	TE0168 ■ 052	TE0163 ■ 052	
<b>Antislip</b>	UGL		TE01BAA ■ 068				TE01BA2 ■ 095
<b>Bricco</b>	UGL		TE01BABR ■ 080				
<b>Irregolo</b>	UGL		TE01BAIR ■ 080				
<b>Mini Irregolo</b>	UGL		TE01BAMI ■ 080				

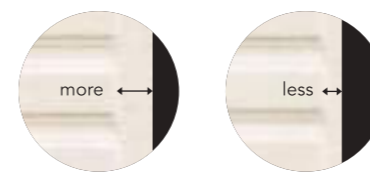

Caratteristiche bordi Bricco, Irregolo, Mini Irregolo. Eventuali disomogeneità dei bordi perimetrali nei moduli Bricco, Irregolo e Mini Irregolo sono da considerarsi non come difetto, ma come caratteristiche del prodotto che, esattamente come accade per i materiali artigianali, possono variare da una produzione all'altra.

Edge features Bricco, Irregolo and Mini Irregolo. Any lack of homogeneity in the perimeter edges of the Bricco, Irregolo and Mini modules should not be considered as defects, but as distinguishing features of the product which, as is the case for craft-based materials, may vary from one product batch to the next.

Eigenschaften der Kanten Bricco, Irregolo und Mini Irregolo. Eventuelle Unregelmäßigkeiten der Kanten bei den Modulen Bricco, Irregolo und Mini Irregolo sind kein Mangel, sondern eine typische Eigenschaft des Produkts, die, genau wie bei handwerklichen Materialien, von einer Produktion zur anderen variieren können.

Caractéristiques des bords Bricco, Irregolo et Mini Irregolo. Les éventuelles irrégularités des bords des modules Bricco, Irregolo et Mini Irregolo sont à considérer non comme des défauts mais comme des caractéristiques du produit qui, exactement comme sur les matériaux de fabrication artisanale, peuvent varier d'une production à l'autre.

Avorio



Canapa



Senape



Cenere



		■ 9 mm - StrideUp					■ 20 mm - OPEN
		120x120 cm 47 <sup>11/16</sup> "x47 <sup>11/16</sup> "	60x120 cm 23 <sup>11/16</sup> "x47 <sup>11/16</sup> "	80x80 cm 31 <sup>11/16</sup> "x31 <sup>11/16</sup> "	60x60 cm 23 <sup>11/16</sup> "x23 <sup>11/16</sup> "	30x60 cm 11 <sup>7/8</sup> "x23 <sup>11/16</sup> "	60x120 cm 23 <sup>11/16</sup> "x47 <sup>11/16</sup> "
StrideUp	UGL	AVORIO TE0212 ■ 078	TE02BA ■ 068	TE0288 ■ 062	TE0268 ■ 052	TE0263 ■ 052	
		CANAPA TE0312 ■ 078	TE03BA ■ 068	TE0388 ■ 062	TE0368 ■ 052	TE0363 ■ 052	
Antislip	UGL	AVORIO TE02BAA ■ 068					
		CANAPA				TE03BA2 ■ 095	

		■ 9 mm - StrideUp				
		120x120 cm 47 <sup>11/16</sup> "x47 <sup>11/16</sup> "	60x120 cm 23 <sup>11/16</sup> "x47 <sup>11/16</sup> "	80x80 cm 31 <sup>11/16</sup> "x31 <sup>11/16</sup> "	60x60 cm 23 <sup>11/16</sup> "x23 <sup>11/16</sup> "	30x60 cm 11 <sup>7/8</sup> "x23 <sup>11/16</sup> "
StrideUp	UGL	SENAPE TE0412 ■ 078	TE04BA ■ 068	TE0488 ■ 062	TE0468 ■ 052	TE0463 ■ 052
		CENERE TE0612 ■ 078	TE06BA ■ 068	TE0688 ■ 062	TE0668 ■ 052	TE0663 ■ 052

## Listello Tratto

20x80

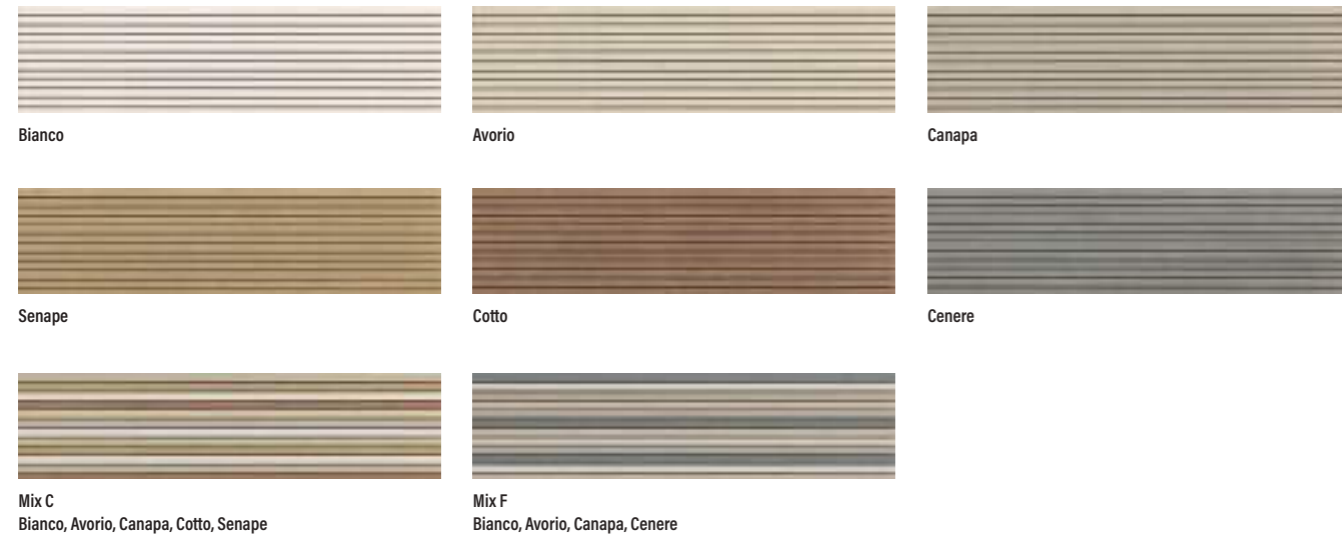

Bianco

Avorio

Canapa

Senape

Cotto

Cenere

Mix C  
Bianco, Avorio, Canapa, Cotto, Senape

Mix F  
Bianco, Avorio, Canapa, Cenere

## Mosaico B

30x30

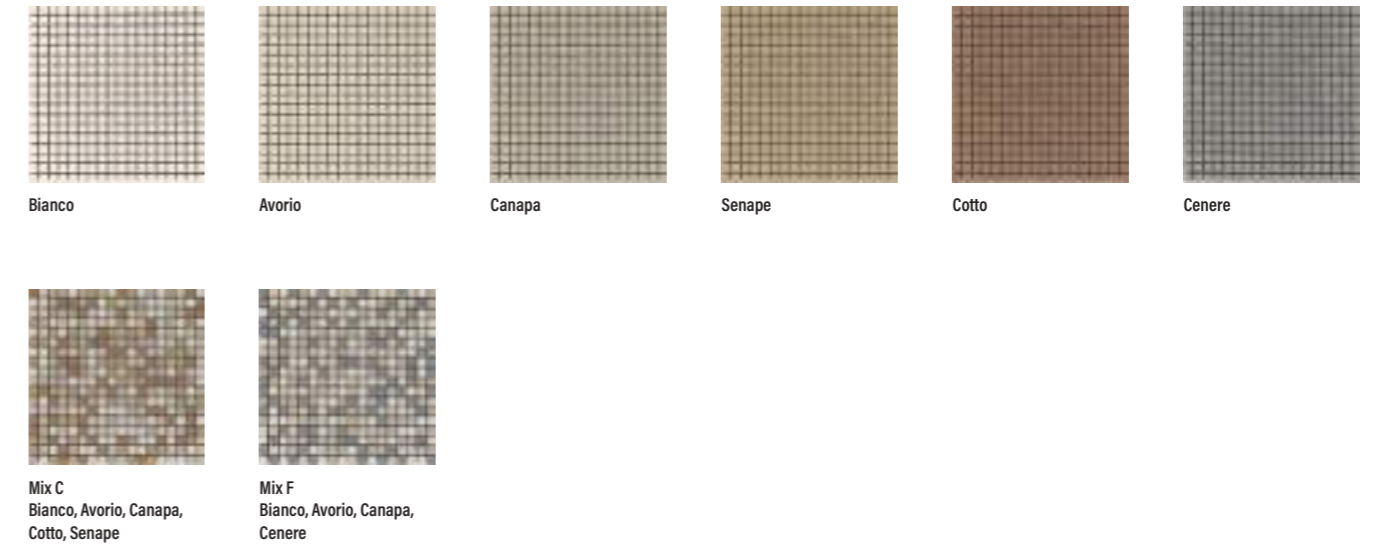

Bianco

Avorio

Canapa

Senape

Cotto

Cenere

Mix C  
Bianco, Avorio, Canapa, Cotto, Senape

Mix F  
Bianco, Avorio, Canapa, Cenere

## Muretto a Spacco

30x50



Bianco

Avorio

Canapa

Senape

Cotto

Cenere

## Mosaico A

30x30

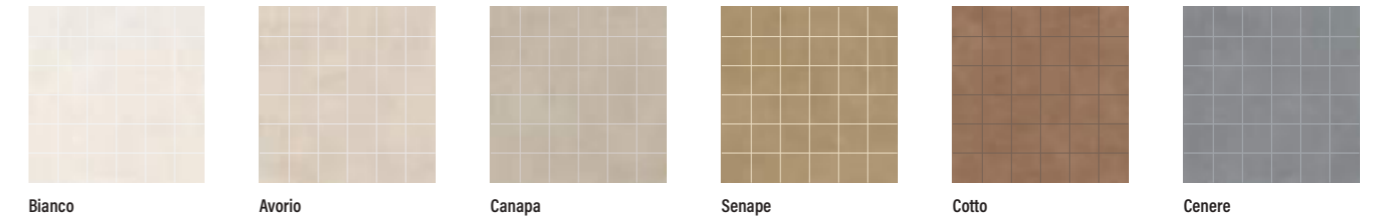

Bianco

Avorio





Canapa

Senape

Cotto

Cenere

■ 9 mm - StrideUp - UGL

				
	Listello Tratto 20x80 cm 8"x31 <sup>1/2</sup> " (Pcs Box 6)	Muretto a Spacco 30x50 cm 11 <sup>7/8</sup> "x17 <sup>11/16</sup> " (Pcs Box 6)	Muretto B 30x30 cm 11 <sup>7/8</sup> "x11 <sup>7/8</sup> " (Pcs Box 6)	Mosaico A 30x30 cm 11 <sup>7/8</sup> "x11 <sup>7/8</sup> " (Pcs Box 12)
<b>BIANCO</b>	TE01LT ■ 045	TE01MS ■ 049	TE013MB ■ 038	TE013MA ■ 137
<b>AVORIO</b>	TE02LT ■ 045	TE02MS ■ 049	TE023MB ■ 038	TE023MA ■ 137
<b>CANAPA</b>	TE03LT ■ 045	TE03MS ■ 049	TE033MB ■ 038	TE033MA ■ 137
<b>SENAPE</b>	TE04LT ■ 045	TE04MS ■ 049	TE043MB ■ 038	TE043MA ■ 137
<b>COTTO</b>	TE05LT ■ 045	TE05MS ■ 049	TE053MB ■ 038	TE053MA ■ 137
<b>CENERE</b>	TE06LT ■ 045	TE06MS ■ 049	TE063MB ■ 038	TE063MA ■ 137
<b>MIX C</b>	TE00LTC ■ 045		TE003MBC ■ 038	
<b>MIX F</b>	TE00LTF ■ 045		TE003MBF ■ 038	

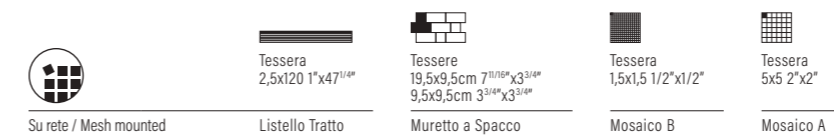

Su rete / Mesh mounted

Listello Tratto

Muretto a Spacco

Mosaico B

Mosaico A

Pezzi speciali / Special pieces

9 mm



BIANCO	StrideUp	TE0176	009	TE01GT2	223
	Antislip			TE0195I	059
AVORIO	StrideUp	TE0276	009	TE02GT2	223
	Antislip			TE0295I	059
CANAPA	StrideUp	TE0376	009	TE03GT2	223

Pezzi speciali / Special pieces

9 mm



SENAPE	StrideUp	TE0476	009	TE04GT2	223
	Antislip			TE0495I	059
COTTO	StrideUp	TE0576	009	TE05GT2	223
	Antislip			TE0595I	059
CENERE	StrideUp	TE0676	009	TE06GT2	223



Irregolo Bianco 60x120, Cenere 120x120



Download Catalogue

20 mm Open - Pezzi speciali / Special pieces

Per approfondimenti sui pezzi speciali e tutti gli accessori per esterno 20mm scarica la scheda tecnica oppure consultare il nostro sito e il catalogo Open.

For further information on special pieces and all 20mm outdoor accessories download the technical data sheet or consult our website and the Open catalog.

Für weitere Informationen zu Sonderteilen und dem gesamten 20mm Outdoor-Zubehör laden Sie das technische Datenblatt herunter oder besuchen Sie unsere Website und den Open-Katalog.

Pour approfondissements sur les pièces de finition et accessoires pour extérieurs en 20mm- merci de télécharger la fiche technique ou bien consulter notre site web et le catalogue OPEN.

Imballi / Packing

				PCS / BOX	M <sup>2</sup> / BOX	KG / BOX	BOX / PALLET	M <sup>2</sup> / PALLET	KG / PALLET
	120x120 cm - 47 <sup>1/4</sup> "x47 <sup>1/4</sup> "	Thick 9 mm	StrideUp	PZ / PCS 02	M <sup>2</sup> 2,88	KG 58,51	PZ / PCS 18	M <sup>2</sup> 51,84	KG 1.073,28
	60x120 cm - 23 <sup>1/2</sup> "x47 <sup>1/4</sup> "	Thick 9 mm	StrideUp	PZ / PCS 02	M <sup>2</sup> 1,44	KG 27,75	PZ / PCS 36	M <sup>2</sup> 51,84	KG 1.019,18
	60x120 cm - 23 <sup>1/2</sup> "x47 <sup>1/4</sup> "	Thick 9 mm	Antislip	PZ / PCS 02	M <sup>2</sup> 1,44	KG 27,61	PZ / PCS 36	M <sup>2</sup> 51,84	KG 1.014,06
	Bricco 60x120 cm - 23 <sup>1/2</sup> "x47 <sup>1/4</sup> "	Thick 9 mm	StrideUp	PZ / PCS 02	M <sup>2</sup> 1,44	KG 28,90	PZ / PCS 36	M <sup>2</sup> 51,84	KG 1.060,54
	Irregolo 60x120 cm - 23 <sup>1/2</sup> "x47 <sup>1/4</sup> "	Thick 9 mm	StrideUp	PZ / PCS 02	M <sup>2</sup> 1,44	KG 27,12	PZ / PCS 36	M <sup>2</sup> 51,84	KG 996,32
	Mini Irregolo 60x120 cm - 23 <sup>1/2</sup> "x47 <sup>1/4</sup> "	Thick 9 mm	StrideUp	PZ / PCS 02	M <sup>2</sup> 1,44	KG 27,18	PZ / PCS 36	M <sup>2</sup> 51,84	KG 998,48
	OPEN 60x120 cm - 23 <sup>1/2</sup> "x47 <sup>1/4</sup> "	Thick 20 mm	Antislip	PZ / PCS 01	M <sup>2</sup> 0,72	KG 32,68	PZ / PCS 36	M <sup>2</sup> 25,92	KG 1.196,51
	80x80 cm - 31 <sup>1/2</sup> "x31 <sup>1/2</sup> "	Thick 9 mm	StrideUp	PZ / PCS 02	M <sup>2</sup> 1,28	KG 25,08	PZ / PCS 42	M <sup>2</sup> 53,76	KG 1.073,44
	60x60 cm - 23 <sup>1/2</sup> "x23 <sup>1/2</sup> "	Thick 9 mm	StrideUp	PZ / PCS 04	M <sup>2</sup> 1,44	KG 27,78	PZ / PCS 30	M <sup>2</sup> 43,20	KG 853,55
	30x60 cm - 11 <sup>7/8</sup> "x23 <sup>1/2</sup> "	Thick 9 mm	StrideUp	PZ / PCS 08	M <sup>2</sup> 1,44	KG 27,36	PZ / PCS 32	M <sup>2</sup> 46,08	KG 859,52
	Listello Tratto 20x80 cm - 8"x31 <sup>1/2</sup> "	Thick 9 mm	StrideUp	PZ / PCS 06	M <sup>2</sup> 0,96	KG 18,40	PZ / PCS 30	M <sup>2</sup> 28,80	KG 572,06
	Mosaico A 30x30 cm - 11 <sup>7/8</sup> "x11 <sup>7/8</sup> "	Thick 9 mm	StrideUp	PZ / PCS 12	M <sup>2</sup> 1,08	KG 21,00	PZ / PCS 30	M <sup>2</sup> 32,40	KG 650,00
	Mosaico B 30x30 cm - 11 <sup>7/8</sup> "x11 <sup>7/8</sup> "	Thick 9 mm	StrideUp	PZ / PCS 06	M <sup>2</sup> 0,54	KG 8,40	PZ / PCS 60	M <sup>2</sup> 32,40	KG 524,00
	Muretto a Spacco 30x50 cm - 11 <sup>7/8</sup> "x17 <sup>1/2</sup> "	Thick 9 mm	StrideUp	PZ / PCS 06	M <sup>2</sup> 0,9	KG 17,80	PZ / PCS 30	M <sup>2</sup> 27,00	KG 554,06

Stucchi consigliati / Recommended grouts

Colori Colors	Bianco	Avorio	Canapa	Senape	Cotto	Cenere
Kerakoll	KK2	KK109	KK109	KK151	KK154	KK8
Mapei	60% 100 + 40% 110	80% 100 + 20% 133	90% 110 + 10% 112	133	70% 142 + 20% 112 + 10% 110	112

Le tipologie di stucchi riportate nella tabella sono semplici suggerimenti. Prima della posa si raccomanda di eseguire un test di stuccatura per verificarne la compatibilità con la superficie ceramica e le condizioni di utilizzo. / The types of grout listed in the table are simply suggestions. Before installation, it is recommended to perform a grouting test to verify compatibility with the ceramic surface and conditions of use. / Die in der Tabelle aufgeführten Fugenmörteltypen sind lediglich Empfehlungen. Vor dem Verlegen wird empfohlen, einen Fugentest durchzuführen, um die Verträglichkeit mit der Keramikoberfläche und den Einsatzbedingungen zu überprüfen. / Les types de mastics indiqués dans le tableau sont de simples suggestions. Avant la pose, il est recommandé d'effectuer un test de masticage afin de vérifier la compatibilité avec la surface céramique et les conditions d'utilisation.



Iron, Plate 120x120

# Metaline

Gres porcellanato - Rettificato / Porcelain Stoneware - Rectified  
Feinsteinzeug - Kalibriert / Gres Cerame - Rectifié

Conforming to Standards  
EN 14411 ISO 13006 APPENDICE G GRUPPO BIa UGL CON Ev ≤ 0,5%



Download  
Catalogue

Caratteristiche tecniche  
Technical features

BENDING STRENGTH	FROST RESISTANCE	CHEMICAL RESISTANCE	STAIN RESISTANCE
ANSI A326.3 > 0,42	R11 / A+B+C	TRAFFICO INTENSO HEAVY TRAFFIC	V2 MODERATE
Naturale / Matte Melt OPEN	Antislip OPEN	Naturale / Matte Melt OPEN	All Colours

Formati  
Sizes

	6 mm	12 mm	9 mm				20 mm - OPEN	
<b>SUPERFICIE SURFACE</b>	120x280x0,6 cm 47 <sup>11/16</sup> x110 <sup>11/16</sup> x1/4"	160x320x1,2 cm 62 <sup>7/8</sup> x125 <sup>5/8</sup> x1/2"	80x160 cm 31 <sup>1/2</sup> x63"	120x120 cm 47 <sup>11/16</sup> x47 <sup>11/16</sup> "	60x120 cm 23 <sup>1/2</sup> x47 <sup>11/16</sup> "	60x60 cm 23 <sup>1/2</sup> x23 <sup>1/2</sup> "	30x60 cm 11 <sup>7/8</sup> x23 <sup>1/2</sup> "	60x60 cm 23 <sup>1/2</sup> x23 <sup>1/2</sup> "
Naturale / Matte Natur / Naturel	■	■	■	■	■	■		
Melt					■			
Antislip							■	

Colori  
Colours

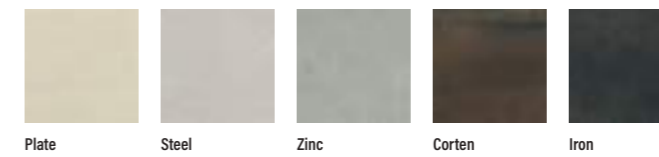

Plate Steel Zinc Corten Iron

Superficie  
Surface finishes



Naturale Matte Melt



Iron 80x160, Steel Mosaico Thorn 29x34



Iron 80x160

Plate



Plate Melt



Steel



Steel Melt



	6 mm	9 mm	20 mm - OPEN
	120x280x0,6 cm 47 <sup>1/4</sup> "x110 <sup>1/4</sup> "x1/4"	120x120 cm 47 <sup>1/4</sup> "x47 <sup>1/4</sup> "	60x120 cm 23 <sup>1/2</sup> "x47 <sup>1/4</sup> "
			60x60 cm 23 <sup>1/2</sup> "x23 <sup>1/2</sup> "
			30x60 cm 11 <sup>7/8</sup> "x23 <sup>1/2</sup> "
Naturale / Matte	UGL ML05XPA ■ 110	ML0512 ■ 078 ML05BA ■ 068	ML0568 ■ 052 ML0563 ■ 052
Melt	UGL	ML05BAM ■ 080	
Antislip	UGL		ML05682 ■ 075

	9 mm
	120x120 cm 47 <sup>1/4</sup> "x47 <sup>1/4</sup> "
	60x120 cm 23 <sup>1/2</sup> "x47 <sup>1/4</sup> "
	60x60 cm 23 <sup>1/2</sup> "x23 <sup>1/2</sup> "
	30x60 cm 11 <sup>7/8</sup> "x23 <sup>1/2</sup> "
Naturale / Matte	UGL ML0112 ■ 078 ML01BA ■ 068 ML0168 ■ 052 ML0163 ■ 052
Melt	UGL ML01BAM ■ 080

Zinc

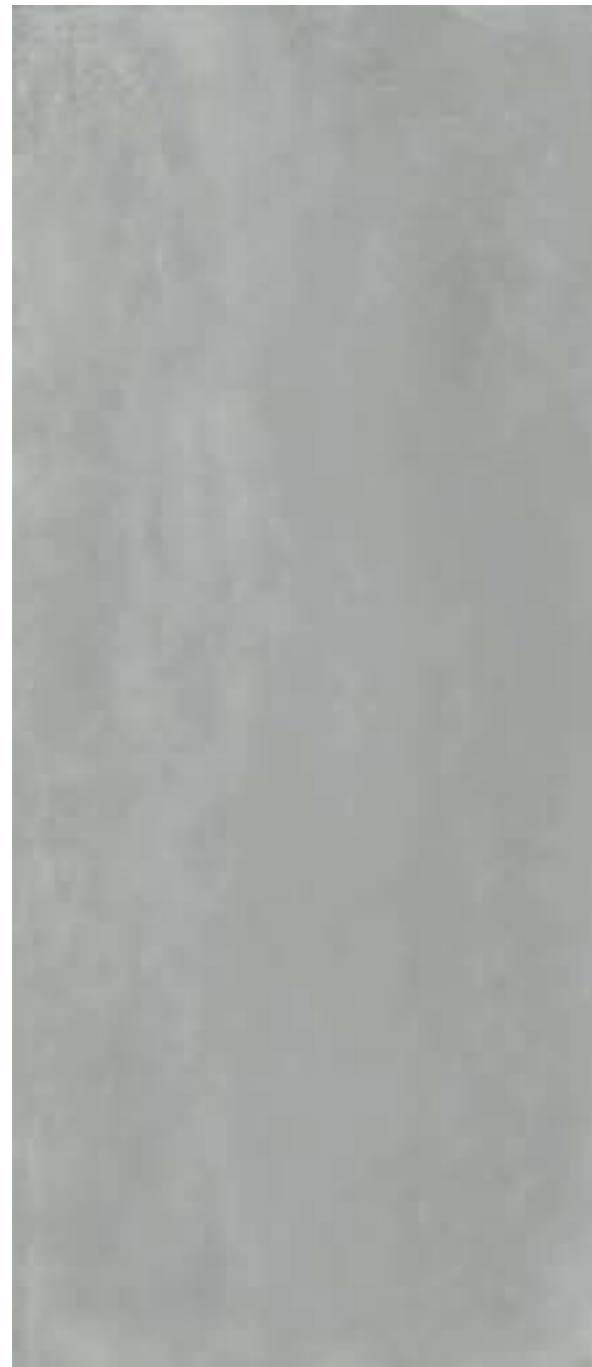

Zinc Melt

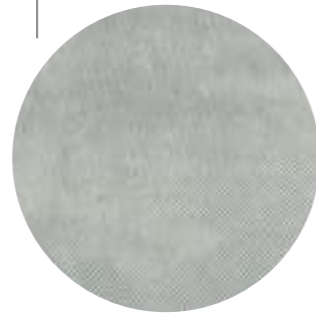

Corten



Corten Melt

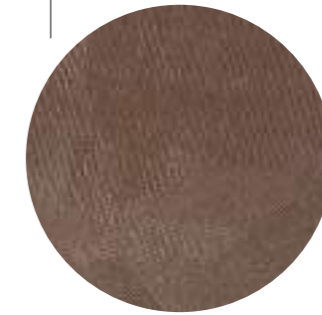

		■ 9 mm				■ 20 mm - OPEN
		120x120 cm 47 <sup>1/4</sup> "x47 <sup>1/4</sup> "	60x120 cm 23 <sup>1/2</sup> "x47 <sup>1/4</sup> "	60x60 cm 23 <sup>1/2</sup> "x23 <sup>1/2</sup> "	30x60 cm 11 <sup>7/8</sup> "x23 <sup>1/2</sup> "	60x60 cm 23 <sup>1/2</sup> "x23 <sup>1/2</sup> "
<b>Naturale / Matte</b>	<b>UGL</b>	ML0412 ■ 078	ML04BA ■ 068	ML0468 ■ 052	ML0463 ■ 052	
<b>Melt</b>	<b>UGL</b>		ML04BAM ■ 080			
<b>Antislip</b>	<b>UGL</b>					ML04682 ■ 075

		■ 6 mm	■ 9 mm				■ 20 mm - OPEN	
		120x280x0,6 cm 47 <sup>1/4</sup> "x110 <sup>1/4</sup> "x1/4"	80x160 cm 31 <sup>1/2</sup> "x63"	120x120 cm 47 <sup>1/4</sup> "x47 <sup>1/4</sup> "	60x120 cm 23 <sup>1/2</sup> "x47 <sup>1/4</sup> "	60x60 cm 23 <sup>1/2</sup> "x23 <sup>1/2</sup> "	30x60 cm 11 <sup>7/8</sup> "x23 <sup>1/2</sup> "	60x60 cm 23 <sup>1/2</sup> "x23 <sup>1/2</sup> "
<b>Naturale / Matte</b>	<b>UGL</b>	ML02XPA ■ 110	ML02GA ■ 078	ML0212 ■ 078	ML02BA ■ 068	ML0268 ■ 052	ML0263 ■ 052	
<b>Melt</b>	<b>UGL</b>				ML02BAM ■ 080			
<b>Antislip</b>	<b>UGL</b>							ML02682 ■ 075

Iron



Iron Melt

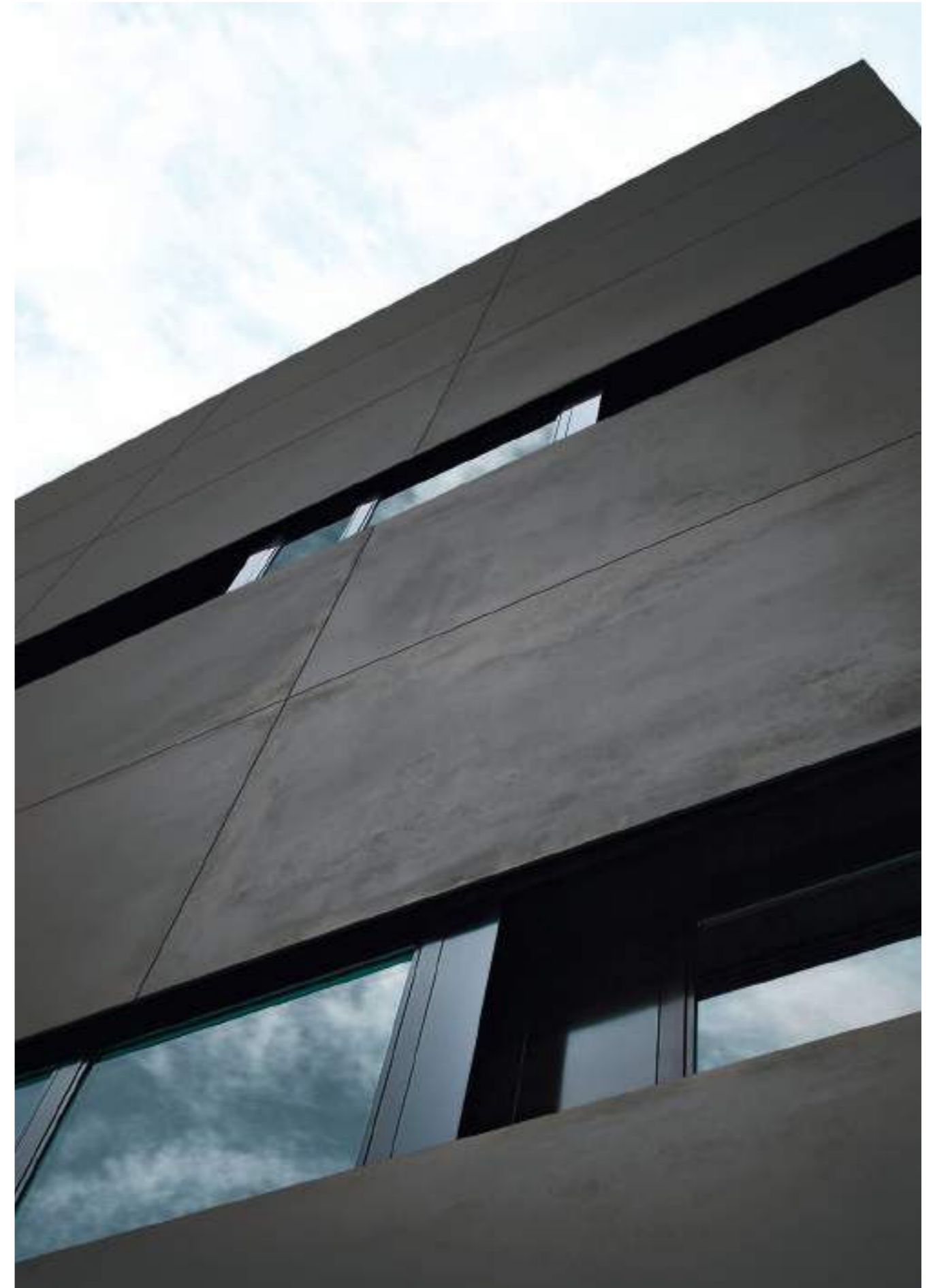
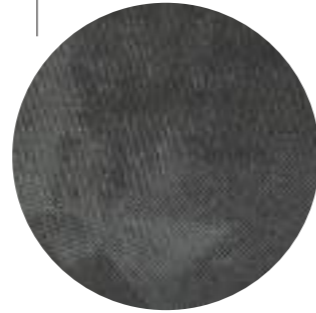

	6 mm	12 mm	9 mm				
	120x280x0,6 cm 47 <sup>1/8</sup> "x110 <sup>1/8</sup> "x1/4"	160x320x1,2 cm 62 <sup>1/8</sup> "x125 <sup>1/8</sup> "x1/2"	80x160 cm 31 <sup>1/2</sup> "x63"	120x120 cm 47 <sup>1/8</sup> "x47 <sup>1/8</sup> "	60x120 cm 23 <sup>1/2</sup> "x47 <sup>1/8</sup> "	60x60 cm 23 <sup>1/2</sup> "x23 <sup>1/2</sup> "	30x60 cm 11 <sup>7/8</sup> "x23 <sup>1/2</sup> "
Naturale / Matte	UGL	UGL	ML03GA 078	ML0312 078	ML03BA 068	ML0368 052	ML0363 052
Melt	UGL	UGL			ML03BAM 080		

Metaline Iron 120x280x0,6

### Mosaico Metal

30x30

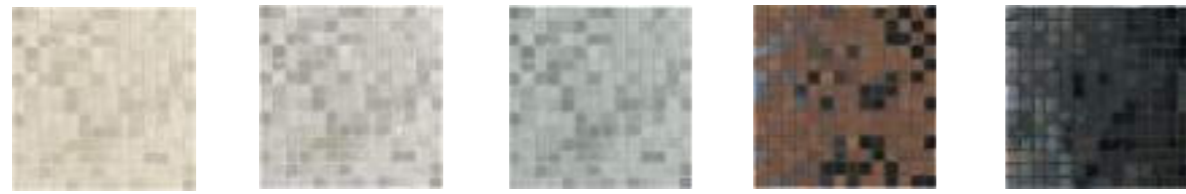

Plate Steel Zinc Corten Iron

### Muretto

30x60

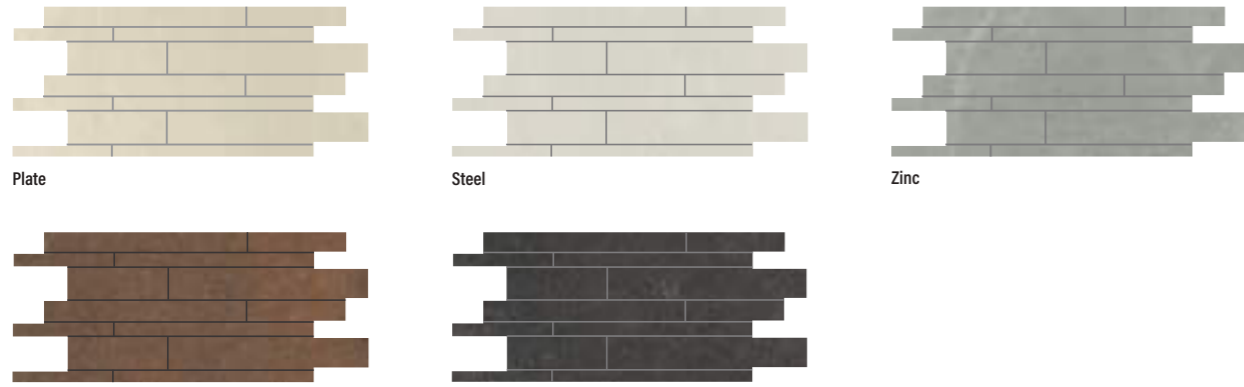

Plate Steel Zinc Corten Iron

### Mosaico

30x30

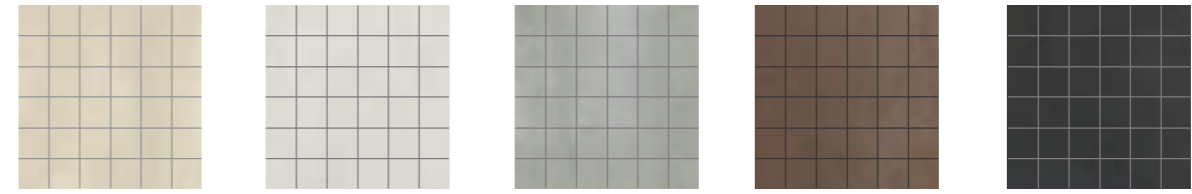

Plate Steel Zinc Corten Iron

### Mosaico Thorn

29x34



Plate Steel Zinc Corten Iron

#### Schemi di posa / Installation systems

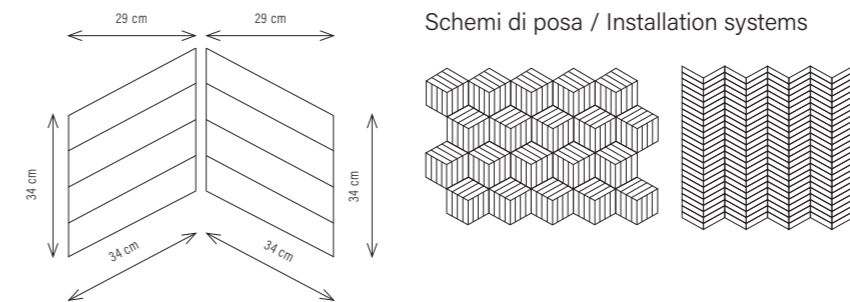

■ 9 mm - Naturale / Matte - UGL

Mosaico Metal 30x30 cm 11 <sup>7/8</sup> "x11 <sup>7/8</sup> " (Pcs Box 4)	Muretto 30x60 cm 11 <sup>7/8</sup> "x23 <sup>1/2</sup> " (Pcs Box 4)	Mosaico 30x30 cm 11 <sup>7/8</sup> "x11 <sup>7/8</sup> " (Pcs Box 12)	Mosaico Thorn* 29x34 11 <sup>7/8</sup> "x13 <sup>1/2</sup> " (Pcs Box 6)

<b>STEEL</b>	ML01ME 519	ML01MB 026	ML013MA 137	ML01MN 038
<b>PLATE</b>	ML05ME 519	ML05MB 026	ML053MA 137	ML05MN 038
<b>ZINC</b>	ML04ME 519	ML04MB 026	ML043MA 137	ML04MN 038
<b>IRON</b>	ML03ME 519	ML03MB 026	ML033MA 137	ML03MN 038
<b>CORTEN</b>	ML02ME 519	ML02MB 026	ML023MA 137	ML02MN 038

\* Il prezzo si riferisce alla vendita del singolo pezzo / Price intended per single piece  
Preis bezieht sich auf das einzeln Stück / Le prix s comprends à l unité

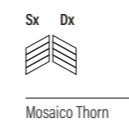

All'interno della scatola sono presenti 3 soggetti dx e 3 soggetti sx / 6 pieces inside each carton, 3 left and 3 right sides / Im Karton sind je 3 Stück rechtes und linkes Muster vorhanden / La boîte est conditionnee avec 3 unités droites et 3 unités gauches



Su rete / Mesh mounted



Muretto



Tessera 5x5 2"x2"  
Mosaico



Tessera 2x2 3/4"x3/4"  
Mosaico Metal

Pezzi speciali / Special pieces

9 mm



Battiscopa  
7x60 cm  
2 3/4"x23 1/2"  
(Pcs Box 10)

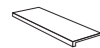

Gradone con Toro  
120x33x4 cm  
47 1/4"x13"x1 3/4"  
(Pcs Box 2)

STEEL	Naturale / Matte	ML0176	009	ML01GT2	223
PLATE	Naturale / Matte	ML0576	009	ML05GT2	223
ZINC	Naturale / Matte	ML0476	009	ML04GT2	223
IRON	Naturale / Matte	ML0376	009	ML03GT2	223
CORTEN	Naturale / Matte	ML0276	009	ML02GT2	223



Download Catalogue

20 mm Open - Pezzi speciali / Special pieces

Per approfondimenti sui pezzi speciali e tutti gli accessori per esterno 20mm scarica la scheda tecnica oppure consultare il nostro sito e il catalogo Open.

For further information on special pieces and all 20mm outdoor accessories download the technical data sheet or consult our website and the Open catalog.

Für weitere Informationen zu Sonderteilen und dem gesamten 20mm Outdoor-Zubehör laden Sie das technische Datenblatt herunter oder besuchen Sie unsere Website und den Open Katalog.

Pour approfondissements sur les pièces de finition et accessoires pour extérieurs en 20mm, merci de télécharger la fiche technique ou bien consulter notre site web et le catalogue OPEN.



Corten 120x280x0,6, Zinc 80x160, Zinc 60x60 20mm

Imballi / Packing

				PCS / BOX	M2 / BOX	KG / BOX	BOX / PALLET	M2 / PALLET	KG / PALLET
	80x160 cm - 31 1/2"x62 1/2"	Thick 9 mm	Naturale	PZ / PCS 02	M <sup>2</sup> 2,56	KG 50,18	PZ / PCS 18	M <sup>2</sup> 46,08	KG 923,40
	120x120 cm - 47 1/4"x47 1/4"	Thick 9 mm	Naturale	PZ / PCS 02	M <sup>2</sup> 2,88	KG 57,33	PZ / PCS 18	M <sup>2</sup> 51,84	KG 1.052,03
	60x120 cm - 23 1/2"x47 1/4"	Thick 9 mm	Naturale / Melt	PZ / PCS 02	M <sup>2</sup> 1,44	KG 28,09	PZ / PCS 36	M <sup>2</sup> 51,84	KG 1.031,34
	60x60 cm - 23 1/2"x23 1/2"	Thick 9 mm	Naturale	PZ / PCS 04	M <sup>2</sup> 1,44	KG 27,90	PZ / PCS 30	M <sup>2</sup> 43,20	KG 857,03
	OPEN 60x60 cm - 23 1/2"x23 1/2"	Thick 20 mm	Antislip	PZ / PCS 02	M <sup>2</sup> 0,72	KG 32,70	PZ / PCS 30	M <sup>2</sup> 21,06	KG 1.001,15
	30x60 cm - 11 3/8"x23 1/2"	Thick 9 mm	Naturale	PZ / PCS 08	M <sup>2</sup> 1,44	KG 27,73	PZ / PCS 32	M <sup>2</sup> 46,08	KG 907,58
	Mosaico Thorn 29x34 cm - 11 3/8"x13 1/2"	Thick 9 mm	Naturale	PZ / PCS 06	M <sup>2</sup> 0,59	KG 12,40	PZ / PCS 40	M <sup>2</sup> 23,66	KG 516,08
	Muretto 30x60 cm - 11 3/8"x23 1/2"	Thick 9 mm	Naturale	PZ / PCS 04	M <sup>2</sup> 0,72	KG 16,00	PZ / PCS 30	M <sup>2</sup> 21,60	KG 500,00
	Mosaico Metal 30x30 cm - 11 3/8"x11 3/8"	Thick 9 mm	Naturale	PZ / PCS 04	M <sup>2</sup> 0,36	KG 6,00	PZ / PCS 48	M <sup>2</sup> 17,28	KG 308,00
	Mosaico 30x30 cm - 11 3/8"x11 3/8"	Thick 9 mm	Naturale	PZ / PCS 12	M <sup>2</sup> 1,08	KG 28,10	PZ / PCS 30	M <sup>2</sup> 32,40	KG 623,00

Imballi Mega / Mega Packing

	DESCRIZIONE IMBALLO PACKAGING DESCRIPTION	MQ / KG LASTRA / SLAB	IMBALLO PIENO FULL PACKAGING	IMBALLO VUOTO EMPTY PACKAGING
	CASSA / CRATE L 145 x P 292 x H 35	MQ 3,36	MQ 67,20	
		KG 48,60	KG 1062,00	KG 100,00
	CAVALLETTO / A-FRAME L 75 x P 285 x H 153	MQ 3,36	MQ 147,84	
		KG 48,60	KG 2318,40	KG 180,00
	CASSA LIGHT / LIGHT CRATE L 145 x P 292 x H 27	MQ 3,36	MQ 30,24	
		KG 48,60	KG 527,40	KG 90,00
			PZ 1 / 9	

Stucchi consigliati / Recommended grouts

Colori Colors	Plate	Steel	Zinc	Corten	Iron
Kerakoll	KK79	KK4	KK8	KK93	KK12
Mapei	110	111	112	80% 136 + 20% 114	70% 114 + 30% 120

Le tipologie di stucchi riportate nella tabella sono semplici suggerimenti. Prima della posa si raccomanda di eseguire un test di stuccatura per verificarne la compatibilità con la superficie ceramica e le condizioni di utilizzo. / The types of grout listed in the table are simply suggestions. Before installation, it is recommended to perform a grouting test to verify compatibility with the ceramic surface and conditions of use. / Die in der Tabelle aufgeführten Fugenmörteltypen sind lediglich Empfehlungen. Vor dem Verlegen wird empfohlen, einen Fugentest durchzuführen, um die Verträglichkeit mit der Keramikoberfläche und den Einsatzbedingungen zu überprüfen. / Les types de mastics indiqués dans le tableau sont de simples suggestions. Avant la pose, il est recommandé d'effectuer un test de masticage afin de vérifier la compatibilité avec la surface céramique et les conditions d'utilisation.

Pag. 415: approfondimenti calibri specifici / Pag. 415: further information on specific working sizes / S. 415: Vertiefungen über spezifische Werkmaße / Pag. 415 : approfondissements dimensions de fabrication spécifiques

**274 Color Effect**

276 Nuances



Luce 120x280x0,6, Muretto Rose 30x30, Giada 120x120

# Nuances

Gres porcellanato - Rettificato / Porcelain Stoneware - Rectified  
Feinsteinzeug - Kalibriert / Gres Cerame - Rectifié

New Innovative  
Technology

StrideUp®



Download  
Catalogue

Conforming to Standards  
EN 14411 ISO 13006 APPENDICE G GRUPPO BIa UGL CON Ev ≤ 0,5%

Caratteristiche tecniche  
Technical features

BENDING STRENGTH	FROST RESISTANCE	CHEMICAL RESISTANCE	STAIN RESISTANCE			
ANSI A326.3 > 0,42	R10 / A + B	ANSI A326.3 > 0,42	ANSI A326.3 > 0,42	R11 / A+B+C	TRAFFICO INTENSO HEAVY TRAFFIC	V2 MODERATE
StrideUp	StrideUp	Naturale / Matte	Antislip OPEN	Antislip OPEN	Naturale / Matte StrideUp Antislip OPEN	All Colours

Formati  
Sizes

<b>SUPERFICIE SURFACE</b>	120x280x0,6 cm 47 <sup>1/4</sup> "x110 <sup>1/4</sup> "x1/4"	120x120 cm 47 <sup>1/4</sup> "x47 <sup>1/4</sup> "	60x120 cm 23 <sup>1/2</sup> "x47 <sup>1/4</sup> "	80x80 cm 31 <sup>1/2</sup> "x31 <sup>1/2</sup> "	60x60 cm 23 <sup>1/2</sup> "x23 <sup>1/2</sup> "	30x60 cm 11 <sup>7/8</sup> "x23 <sup>1/2</sup> "	60x120 cm 23 <sup>1/2</sup> "x47 <sup>1/4</sup> "
Naturale / Matte Natur / Naturel	■						
StrideUp		■	■	■	■	■	
Ribbed			■				
Antislip			■				■

Colori  
Colours

Luce	Rose	Giada	Cielo	Cipria	Fiamma	Grigio	Salvia	Tortora	Marrone
Antracite	Nero	Bianco	Avorio	Bianco Coccio	Avorio Coccio	Grigio Coccio	Antracite Coccio	Tortora Coccio	Cipria Coccio

Superficie  
Surface finishes

Naturale Matte	Ribbed	StrideUp	Antislip



Giada 120x280x0,6, 120x120, Loom Piano 180, Flow Giada



Rose 120x280x0,6, 120x120, Ribbed Rose 60x120, Loom Piano Angle 110



Muretto Luce 30x30, Luce 120x280x0,6, 120x120, Muretto Luce 30x30, Loom Cilindro 50

Luce



Rose



Giada



Cielo



		6 mm		9 mm - StrideUp			
		120x280x0,6 cm 47 <sup>1/4</sup> x110 <sup>1/4</sup> x1/4"	120x120 cm 47 <sup>1/4</sup> x47 <sup>1/4</sup> "	60x120 cm 23 <sup>1/2</sup> x47 <sup>1/4</sup> "	80x80 cm 31 <sup>1/2</sup> x31 <sup>1/2</sup> "		
Naturale / Matte	UGL	LUCE	NU13XPA ■ 110				
		ROSE	NU12XPA ■ 110				
StrideUp	UGL	LUCE	NU1312 ■ 078	NU13BA ■ 068	NU1388 ■ 062		
		ROSE	NU1212 ■ 078	NU12BA ■ 068	NU1288 ■ 062		

		6 mm		9 mm - StrideUp			
		120x280x0,6 cm 47 <sup>1/4</sup> x110 <sup>1/4</sup> x1/4"	120x120 cm 47 <sup>1/4</sup> x47 <sup>1/4</sup> "	60x120 cm 23 <sup>1/2</sup> x47 <sup>1/4</sup> "	80x80 cm 31 <sup>1/2</sup> x31 <sup>1/2</sup> "		
Naturale / Matte	UGL	GIADA	NU14XPA ■ 110				
		CIELO	NU10XPA ■ 110				
StrideUp	UGL	GIADA	NU1412 ■ 078	NU14BA ■ 068	NU1488 ■ 062		
		CIELO	NU1012 ■ 078	NU10BA ■ 068	NU1088 ■ 062		

Cipria



Fiamma



Grigio



Salvia



		6 mm		9 mm - StrideUp								
		120x280x0,6 cm 47 1/4"x110 1/4"x1/4"	120x120 cm 47 1/4"x47 1/4"	60x120 cm 23 1/2"x47 1/4"	80x80 cm 31 1/2"x31 1/2"	60x60 cm 23 1/2"x23 1/2"	30x60 cm 11 7/8"x23 1/2"					
Naturale / Matte	UGL	CIPRIA	NU07XPA	0110								
		FIAMMA	NU11XPA	0110								
StrideUp	UGL	CIPRIA	NU0712	0078	NU07BA	0068	NU0788	0062	NU0768	0052	NU0763	0052
		FIAMMA	NU1112	0078	NU11BA	0068	NU1188	0062				
Antislip	UGL	CIPRIA	NU07BAA			0068						

		6 mm		9 mm - StrideUp						20 mm - OPEN		
		120x280x0,6 cm 47 1/4"x110 1/4"x1/4"	120x120 cm 47 1/4"x47 1/4"	60x120 cm 23 1/2"x47 1/4"	80x80 cm 31 1/2"x31 1/2"	60x60 cm 23 1/2"x23 1/2"	30x60 cm 11 7/8"x23 1/2"	60x120 cm 23 1/2"x47 1/4"				
Naturale / Matte	UGL	GRIGIO	NU02XPA	0110								
		SALVIA	NU09XPA	0110								
StrideUp	UGL	GRIGIO	NU0212	0078	NU02BA	0068	NU0288	0062	NU0268	0052	NU0263	0052
		SALVIA	NU0912	0078	NU09BA	0068	NU0988	0062				
Antislip	UGL	GRIGIO	NU02BAA			0068					NU02BA2	0095

Tortora



Marrone



Antracite



Nero



		6 mm		9 mm - StrideUp				20 mm - OPEN	
		120x280x0,6 cm 47 1/8" x 110 1/8" x 1/4"	120x120 cm 47 1/8" x 47 1/8"	60x120 cm 23 1/2" x 47 1/8"	80x80 cm 31 1/2" x 31 1/2"	60x60 cm 23 1/2" x 23 1/2"	30x60 cm 11 7/8" x 23 1/2"	60x120 cm 23 1/2" x 47 1/8"	
Naturale / Matte	UGL	TORTORA NU06XPA ■ 110							
	UGL	MARRONE NU08XPA ■ 110							
StrideUp	UGL	TORTORA	NU0612 ■ 078	NU06BA ■ 068	NU0688 ■ 062	NU0668 ■ 052	NU0663 ■ 052		
	UGL	MARRONE	NU0812 ■ 078	NU08BA ■ 068	NU0888 ■ 062	NU0868 ■ 052	NU0863 ■ 052		
Antislip	UGL	TORTORA		NU06BAA ■ 068				NU06BA2 ■ 095	
	UGL	MARRONE		NU08BAA ■ 068					

		6 mm		9 mm - StrideUp				20 mm - OPEN	
		120x280x0,6 cm 47 1/8" x 110 1/8" x 1/4"	120x120 cm 47 1/8" x 47 1/8"	60x120 cm 23 1/2" x 47 1/8"	80x80 cm 31 1/2" x 31 1/2"	60x60 cm 23 1/2" x 23 1/2"	30x60 cm 11 7/8" x 23 1/2"	60x120 cm 23 1/2" x 47 1/8"	
Naturale / Matte	UGL	ANTRACITE NU03XPA ■ 110							
	UGL	NERO NU04XPA ■ 110							
StrideUp	UGL	ANTRACITE	NU0312 ■ 078	NU03BA ■ 068	NU0388 ■ 062	NU0368 ■ 052	NU0363 ■ 052		
	UGL	NERO	NU0412 ■ 078	NU04BA ■ 068	NU0488 ■ 062	NU0468 ■ 052	NU0463 ■ 052		
Antislip	UGL	ANTRACITE		NU03BAA ■ 068				NU03BA2 ■ 095	
	UGL	NERO		NU04BAA ■ 068					

Bianco



Avorio



		6 mm		9 mm - StrideUp							
		120x280x0,6 cm 47 1/8" x 110 1/8" x 1/4"	120x120 cm 47 1/8" x 47 1/8"	60x120 cm 23 1/2" x 47 1/8"	80x80 cm 31 1/2" x 31 1/2"	60x60 cm 23 1/2" x 23 1/2"	30x60 cm 11 7/8" x 23 1/2"				
Naturale / Matte	UGL	BIANCO NU01XPA ■ 110									
		AVORIO NU05XPA ■ 110									
StrideUp	UGL	BIANCO	NU0112 ■ 078	NU01BA ■ 068	NU0188 ■ 062	NU0168 ■ 052	NU0163 ■ 052				
		AVORIO	NU0512 ■ 078	NU05BA ■ 068	NU0588 ■ 062	NU0568 ■ 052	NU0563 ■ 052				
Antislip	UGL	BIANCO	NU01BAA ■ 068								
		AVORIO	NU05BAA ■ 068								

Bianco 120x280x0,6, 120x120, Loom Piano 70

Luce Ribbed



Rose Ribbed

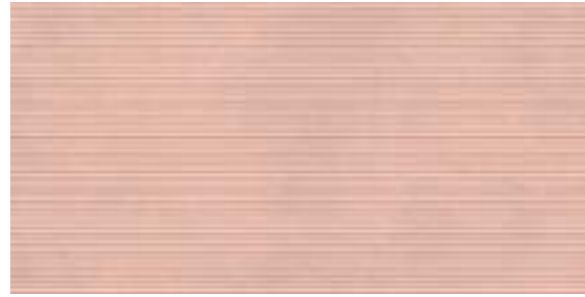

Giada Ribbed



Cielo Ribbed



Bianco Ribbed



Salvia Ribbed



■ 9 mm  
Naturale / Matte - UGL

Ribbed  
60x120 cm  
23<sup>1/2</sup>"x47<sup>1/4</sup>"  
(Pcs Box 2)

<b>LUCE</b>	NU13BAR	■ 080
<b>ROSE</b>	NU12BAR	■ 080
<b>GIADA</b>	NU14BAR	■ 080
<b>CIELO</b>	NU10BAR	■ 080
<b>BIANCO</b>	NU01BAR	■ 080
<b>SALVIA</b>	NU09BAR	■ 080

Il Decoro Ribbed non garantisce continuità di struttura tra un pezzo e l'altro. / The Ribbed Decor does not guarantee continuity of the structure between pieces. / Bei dem Dekor Ribbed ist die Kontinuität der Linienstruktur zwischen einem Stück und dem nächsten nicht gewährleistet. / Le décor Ribbed ne garanti aucune continuité entre une pièce et l'autre.



Ribbed Salvia 60x120, Muretto Grigio 30x30, Grigio 120x120

Coccio



Bianco Coccio



Avorio Coccio



Grigio Coccio

■ 9 mm - StrideUp

60x120 cm 23 <sup>1/2</sup> "x47 <sup>1/4</sup> " (Pcs Box 2)	80x80 cm 31 <sup>1/2</sup> "x31 <sup>1/2</sup> " (Pcs Box 2)
---	--

StrideUp	UGL	BIANCO COCCIO	NU01BAC	080	NU0188C	074
		AVORIO COCCIO	NU05BAC	080	NU0588C	074
		GRIGIO COCCIO	NU02BAC	080	NU0288C	074

Coccio



Antracite Coccio



Cipria Coccio

■ 9 mm - StrideUp

60x120 cm 23 <sup>1/2</sup> "x47 <sup>1/4</sup> " (Pcs Box 2)	80x80 cm 31 <sup>1/2</sup> "x31 <sup>1/2</sup> " (Pcs Box 2)
---	--

StrideUp	UGL	ANTRACITE COCCIO	NU03BAC	080	NU0388C	074
		TORTORA COCCIO	NU06BAC	080	NU0688C	074
		CIPRIA COCCIO	NU07BAC	080	NU0788C	074

Sfumatura Cielo



Sfumatura Cipria



6 mm



120x280x0,6 cm (1pz)  
47 1/4"x110 1/4"x1/4"

Naturale / Matte	UGL	SFUMATURA CIELO	NUS2XPAD	3299
		SFUMATURA CIPRIA	NUS1XPAD	3299

Decoro Sfumatura Cielo 120x280x0,6, Tortora 120x120

## Botanica Verde

120x280x0,6



A

B

6 mm  
Naturale / Matte - UGL



120x280x0,6 cm (1pz)  
47 1/4"x110 1/4"x1/4"

BOTANICA VERDE A	NUB1XPADA	■ 2792
BOTANICA VERDE B	NUB1XPADB	■ 2792

## Botanica Verde Decoro

60x120



A

B

LA COMPOSIZIONE

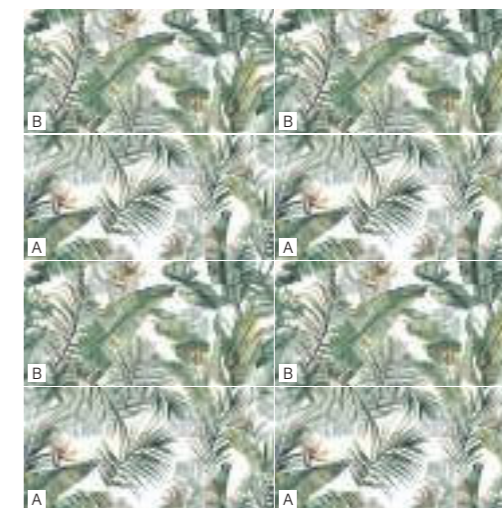

9 mm



120x120  
(60x120 cm 2pz)  
(23 1/2"x47 1/4")

BOTANICA VERDE DECORO	NU00DB1	■ 712
-----------------------	---------	-------

I decori sono stati studiati per comporre le intere pareti in diverse dimensioni; il disegno si riprende sui vari lati. Si consiglia di comporre il disegno prima della posa.

The decorations have been thought to compose the entire walls in different sizes; the design resumes on the various sides. It is recommended to compose the drawing before laying.

Die Dekorationen wurden studiert, um die gesamten Wände in verschiedenen Größen zusammensetzen; das Design setzt sich auf den verschiedenen Seiten fort. Es ist ratsam, die Zeichnung vor dem Verlegen zu erstellen.

Les décors ont été conçus pour composer des murs entières en différents dimensions; le motif se situe sur les différents cotés. Une pose à sec avant le collage est fortement préconisé.

# Botanica Cipria

120x280x0,6



A

B

6 mm  
Naturale / Matte - UGL



120x280x0,6 cm (1pz)  
47 1/4"x110 1/4"x1/4"

BOTANICA CIPRIA A	NUB2XPADA	2792
BOTANICA CIPRIA B	NUB2XPADB	2792

# Botanica Cipria

60x120



A

B

LA COMPOSIZIONE



9 mm



120x120  
(60x120 cm 2pz)  
(23 1/2"x47 1/4")

BOTANICA CIPRIA DECORO	NU00DB2	712
------------------------	---------	-----

I decori sono stati studiati per comporre le intere pareti in diverse dimensioni; il disegno si riprende sui vari lati. Si consiglia di comporre il disegno prima della posa.

The decorations have been thought to compose the entire walls in different sizes; the design resumes on the various sides. It is recommended to compose the drawing before laying.

Die Dekorationen wurden studiert, um die gesamten Wände in verschiedenen Größen zusammensetzen; das Design setzt sich auf den verschiedenen Seiten fort. Es ist ratsam, die Zeichnung vor dem Verlegen zu erstellen.

Les décors ont été conçus pour composer des murs entières en différents dimensions; le motif se situe sur les différents cotés. Une pose à sec avant le collage est fortement préconisé.

# Triangolo Cielo

120x280x0,6



A

B

C

6 mm  
Naturale / Matte - UGL



120x280x0,6 cm (1pz)  
47 1/4"x110 1/4"x1/4"

TRIANGOLO CIELO A	NUTIXPADA	2146
TRIANGOLO CIELO B	NUTIXPADB	2146
TRIANGOLO CIELO C	NUTIXPADC	2146

# Triangolo Cielo Decoro

60x120



LA COMPOSIZIONE

A

B

C

9 mm



180x120  
(60x120 cm 3pz)  
(23 1/2"x47 1/4")

TRIANGOLO CIELO DECORO	NU00DT1	1068
------------------------	---------	------

I decori sono stati studiati per comporre le intere pareti in diverse dimensioni; il disegno si riprende sui vari lati. Si consiglia di comporre il disegno prima della posa.

The decorations have been thought to compose the entire walls in different sizes; the design resumes on the various sides. It is recommended to compose the drawing before laying.

Die Dekorationen wurden studiert, um die gesamten Wände in verschiedenen Größen zusammensetzen; das Design setzt sich auf den verschiedenen Seiten fort. Es ist ratsam, die Zeichnung vor dem Verlegen zu erstellen.

Les décors ont été conçus pour composer des murs entières en différents dimensions; le motif se suive sur les différents cotés. Une pose à sec avant le collage est fortement préconisé.

# Triangolo Cipria

120x280x0,6



A

B

C

6 mm  
Naturale / Matte - UGL



120x280x0,6 cm (1pz)  
47 1/4"x110 1/4"x1/4"

TRIANGOLO CIPRIA A	NUT2XPADA	2146
TRIANGOLO CIPRIA B	NUT2XPADB	2146
TRIANGOLO CIPRIA C	NUT2XPADC	2146

# Triangolo Cipria Decoro

60x120



LA COMPOSIZIONE

A

B

C

9 mm



180x120  
(60x120 cm 3pz)  
(23 1/2"x47 1/4")

TRIANGOLO CIELO DECORO	NU00DT2	1068
------------------------	---------	------

I decori sono stati studiati per comporre le intere pareti in diverse dimensioni; il disegno si riprende sui vari lati. Si consiglia di comporre il disegno prima della posa.

The decorations have been thought to compose the entire walls in different sizes; the design resumes on the various sides. It is recommended to compose the drawing before laying.

Die Dekorationen wurden studiert, um die gesamten Wände in verschiedenen Größen zusammensetzen; das Design setzt sich auf den verschiedenen Seiten fort. Es ist ratsam, die Zeichnung vor dem Verlegen zu erstellen.

Les décors ont été conçus pour composer des murs entières en différents dimensions; le motif se suive sur les différents cotés. Une pose à sec avant le collage est fortement préconisé.

# Foliage

120x280x0,6



A

B

C

6 mm  
Naturale / Matte - UGL



120x280x0,6 cm (1pz)  
47 1/4"x110 1/4"x1/4"

FOLIAGE A	NUFOXPAD A	2146
FOLIAGE B	NUFOXPAD B	2146
FOLIAGE C	NUFOXPAD C	2146

# Foliage Decoro

60x120



A

B

LA COMPOSIZIONE

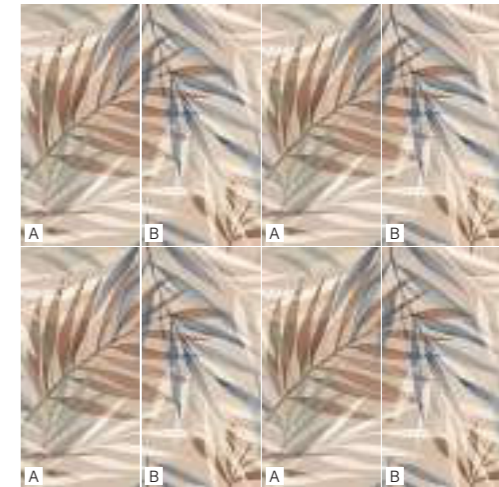

9 mm



120x120  
(60x120 cm 2pz)  
(23 1/2"x47 1/4")

FOLIAGE DECORO	NU00DF2	712
----------------	---------	-----

## Foliage Decoro

I decori sono stati studiati per comporre le intere pareti in diverse dimensioni; il disegno si riprende sui vari lati. Si consiglia di comporre il disegno prima della posa.

The decorations have been thought to compose the entire walls in different sizes; the design resumes on the various sides. It is recommended to compose the drawing before laying.

Die Dekorationen wurden studiert, um die gesamten Wände in verschiedenen Größen zusammensetzen; das Design setzt sich auf den verschiedenen Seiten fort. Es ist ratsam, die Zeichnung vor dem Verlegen zu erstellen.

Les décors ont été conçues pour composer des murs entières en différents dimensions; le motif se suivent sur les différents cotés. Une pose à sec avant le collage est fortement préconisé.

# Wild

120x280x0,6



A



B

6 mm  
Naturale / Matte - UGL



120x280x0,6 cm  
47 1/4" x 110 1/4" x 1/4"  
(Pcs Box 1)

WILD A	EEWOXPADA	3115
WILD B	EEWOXPADB	3115

# Wild Decoro

60x120



A

B

LA COMPOSIZIONE



# Eden Decoro

60x120



LA COMPOSIZIONE



9 mm  
Naturale / Matte - UGL



120x120  
(60x120 cm 2pz)  
(23 1/2" x 47 1/4")

WILD DECORO	EE00DW	826
-------------	--------	-----

### Wild Decoro

I decori sono stati studiati per comporre le intere pareti in diverse dimensioni; il disegno si riprende sui vari lati. Si consiglia di comporre il disegno prima della posa.

The decorations are designed to compose the entire walls with different sizes; the design is repeated on various sides. It is advisable to compose the design before laying.

Das Dekor Eden besteht aus einem einzigen Motiv. Das Design ist für eine willkürliche Verlegung ausgelegt, die Platten drehen und abwechseln, um eine natürlichere Verteilung zu erzielen.

La décoration Eden présente un sujet unique. Le dessin est conçu pour une pose au hasard : il est conseillé d'alterner et de tourner les pièces pour une répartition plus naturelle.

9 mm  
Naturale / Matte - UGL



60x120 cm (2pz)  
23 1/2" x 47 1/4"

EDEN DECORO	NU00BAED	080
-------------	----------	-----

### Eden Decoro

Il decoro Eden presenta un soggetto unico. Il disegno è progettato per una posa random: si consiglia di alternare e ruotare i pezzi per una distribuzione più naturale.

The Eden deco features 1 unique subject. The pattern is designed for a random installation, we recommend to alternate and rotate the pieces for a more natural distribution.

Das Dekor Eden besteht aus einem einzigen Motiv. Das Design ist für eine willkürliche Verlegung ausgelegt, die Platten drehen und abwechseln, um eine natürlichere Verteilung zu erzielen.

La décoration Eden présente un sujet unique. Le dessin est conçu pour une pose au hasard : il est conseillé d'alterner et de tourner les pièces pour une répartition plus naturelle.

## Listello Tratto

20x120



Luce Giada Rose Cielo Salvia Fiamma Marrone  
Cipria Tortora Nero Antracite Grigio Avorio Bianco

## Muretto

30x30

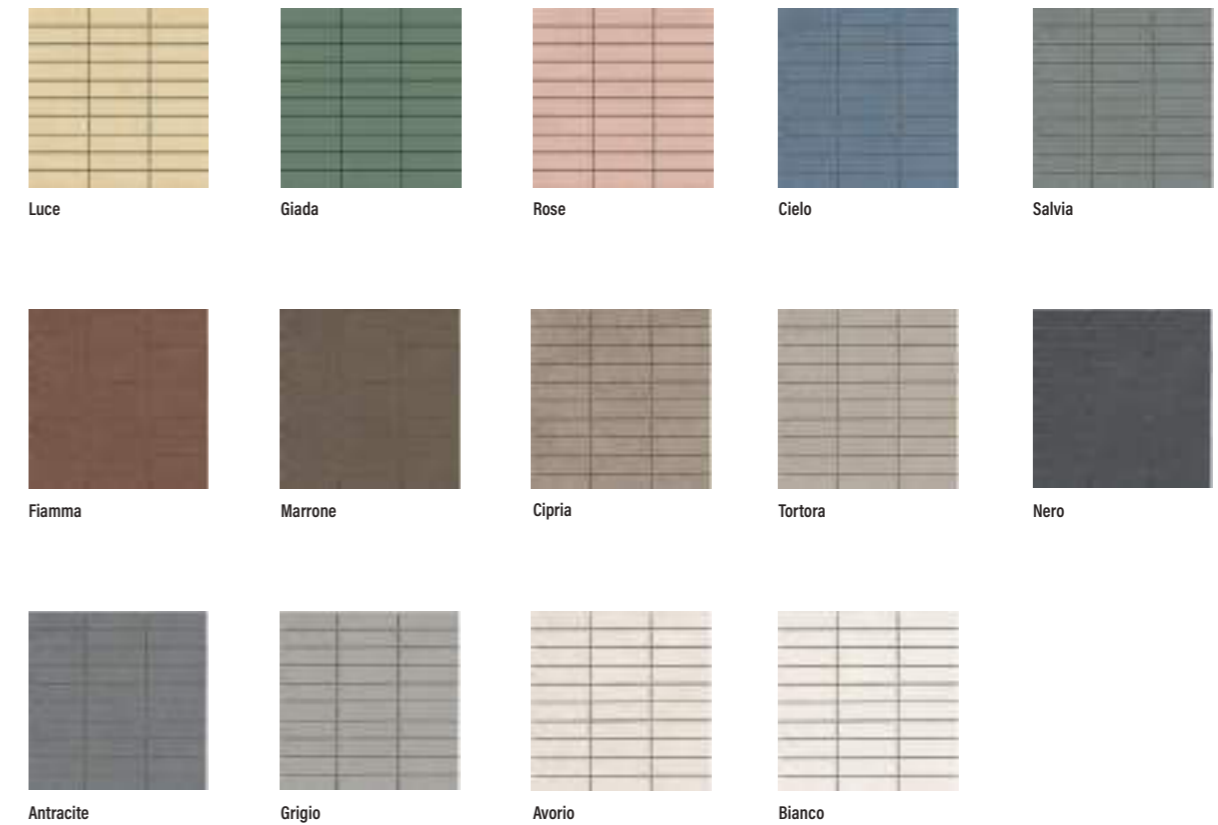

Luce Giada Rose Cielo Salvia  
Fiamma Marrone Cipria Tortora Nero  
Antracite Grigio Avorio Bianco

6 mm - Naturale / Matte - UGL

Listello Tratto  
20x120 cm  
8"x47 1/4"  
(Pcs Box 6)

<b>LUCE</b>	NU13LT 098	<b>AVORIO</b>	NU05LT 098
<b>ROSE</b>	NU12LT 098	<b>TORTORA</b>	NU06LT 098
<b>GIADA</b>	NU14LT 098	<b>CIPRIA</b>	NU07LT 098
<b>BIANCO</b>	NU01LT 098	<b>MARRONE</b>	NU08LT 098
<b>GRIGIO</b>	NU02LT 098	<b>SALVIA</b>	NU09LT 098
<b>ANTRACITE</b>	NU03LT 098	<b>CIELO</b>	NU10LT 098
<b>NERO</b>	NU04LT 098	<b>FIAMMA</b>	NU11LT 098



Su rete / Mesh mounted



Tessera  
2,5x120 1"x47 1/4"



Tessera  
2,8x9,8 1 1/8"x3 7/8"

6 mm - Naturale / Matte - UGL



Muretto  
30x30 cm  
11 7/8"x11 7/8"  
(Pcs Box 6)

<b>LUCE</b>	NU13MB 043	<b>AVORIO</b>	NU05MB 043
<b>ROSE</b>	NU12MB 043	<b>TORTORA</b>	NU06MB 043
<b>GIADA</b>	NU14MB 043	<b>CIPRIA</b>	NU07MB 043
<b>BIANCO</b>	NU01MB 043	<b>MARRONE</b>	NU08MB 043
<b>GRIGIO</b>	NU02MB 043	<b>SALVIA</b>	NU09MB 043
<b>ANTRACITE</b>	NU03MB 043	<b>CIELO</b>	NU10MB 043
<b>NERO</b>	NU04MB 043	<b>FIAMMA</b>	NU11MB 043

9 mm - RealUp + StrideUp - UGL



Muretto  
30x30 cm  
11 7/8"x11 7/8"  
(Pcs Box 6)

<b>LUCE</b>	NU13MB9 027	<b>AVORIO</b>	NU05MB9 027
<b>ROSE</b>	NU12MB9 027	<b>TORTORA</b>	NU06MB9 027
<b>GIADA</b>	NU14MB9 027	<b>CIPRIA</b>	NU07MB9 027
<b>BIANCO</b>	NU01MB9 027	<b>MARRONE</b>	NU08MB9 027
<b>GRIGIO</b>	NU02MB9 027	<b>SALVIA</b>	NU09MB9 027
<b>ANTRACITE</b>	NU03MB9 027	<b>CIELO</b>	NU10MB9 027
<b>NERO</b>	NU04MB9 027	<b>FIAMMA</b>	NU11MB9 027

### Mosaico A

30x30

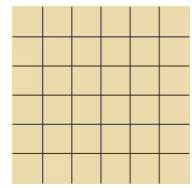

Luce

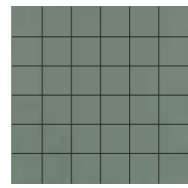

Giada

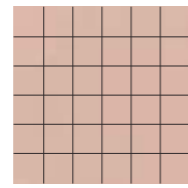

Rose

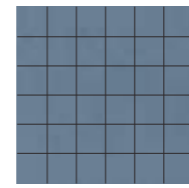

Cielo

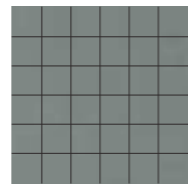

Salvia

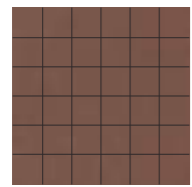

Fiamma

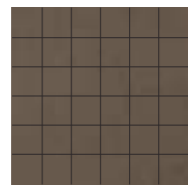

Marrone

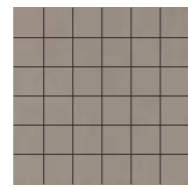

Cipria

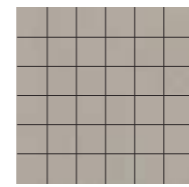

Tortora

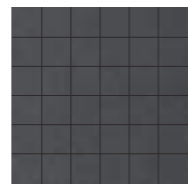

Nero

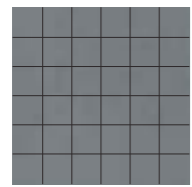

Antracite

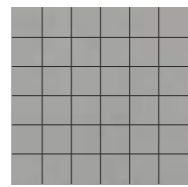

Grigio

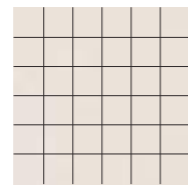

Avorio

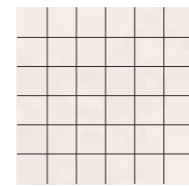

Bianco

### Mosaico Ovale

19,5x37



Cielo



Salvia

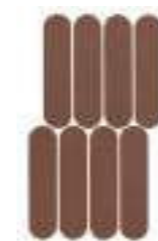

Fiamma



Marrone



Cipria



Tortora



Nero



Antracite



Grigio



Avorio



Bianco

### Mosaico Ovale Mix

19,5x37



Mix Caldo 1  
(Avorio, Tortora, Cipria, Marrone)



Mix Caldo 2  
(Avorio, Tortora, Cipria, Fiamma)



Mix Freddo 1  
(Bianco, Grigio, Antracite, Nero)



Mix Freddo 2  
(Bianco, Grigio, Antracite, Cielo)



Mix Freddo 3  
(Bianco, Grigio, Antracite, Salvia)

■ 9 mm - StrideUp - UGL



Mosaico  
30x30 cm  
11<sup>7/8</sup>"x11<sup>7/8</sup>"  
(Pcs Box 12)

LUCE	NU133MA	137	AVORIO	NU053MA	137
ROSE	NU123MA	137	TORTORA	NU063MA	137
GIADA	NU143MA	137	CIPRIA	NU073MA	137
BIANCO	NU013MA	137	MARRONE	NU083MA	137
GRIGIO	NU023MA	137	SALVIA	NU093MA	137
ANTRACITE	NU033MA	137	CIELO	NU103MA	137
NERO	NU043MA	137	FIAMMA	NU113MA	137

■ 9 mm - StrideUp - UGL



Mosaico Ovale  
19,5x37 cm  
7<sup>5/8</sup>"x14<sup>5/8</sup>"  
(Pcs Box 6)

BIANCO	NU01MOV	042	MARRONE	NU08MOV	042
GRIGIO	NU02MOV	042	SALVIA	NU09MOV	042
ANTRACITE	NU03MOV	042	CIELO	NU10MOV	042
NERO	NU04MOV	042	FIAMMA	NU11MOV	042
AVORIO	NU05MOV	042			
TORTORA	NU06MOV	042			
CIPRIA	NU07MOV	042			

■ 9 mm - StrideUp - UGL



Mosaico Ovale Mix  
19,5x37 cm  
7<sup>5/8</sup>"x14<sup>5/8</sup>"  
(Pcs Box 6)

MIX CALDO 1	NU00MOV1	042
MIX CALDO 2	NU00MOV2	042
MIX FREDDO 1	NU00MOV1	042
MIX FREDDO 2	NU00MOV2	042
MIX FREDDO 3	NU00MOV3	042



Su rete / Mesh mounted



Tessera  
5x5 2"x2"



Tessera  
4,7x18,7 1<sup>7/8</sup>"x7<sup>3/8</sup>"

## Mosaico B

30x30

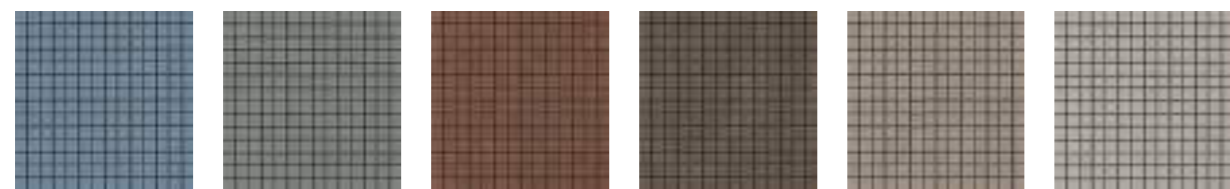

Cielo Salvia Fiamma Marrone Cipria Tortora

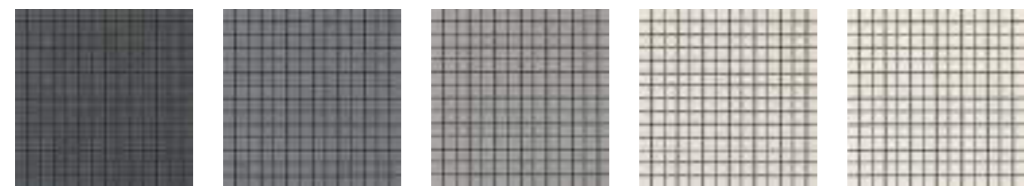

Nero Antracite Grigio Avorio Bianco

## Mosaico Listelli

30x30



Cielo Salvia Fiamma Marrone Cipria Tortora



Nero Antracite Grigio Avorio Bianco

## Mosaico Triangoli Mix\*

30x30



Mix Caldo 1 (Avorio, Tortora, Cipria) Mix Caldo 2 (Avorio, Tortora, Fiamma) Mix Freddo 1 (Bianco, Grigio, Salvia) Mix Freddo 2 (Bianco, Grigio, Cielo) Mix Freddo 3 (Bianco, Grigio, Antracite)

## Mosaico Listelli Mix\*\*

30x30



Mix Caldo 1 (Avorio, Tortora, Cipria, Marrone) Mix Caldo 2 (Avorio, Tortora, Cipria, Fiamma) Mix Freddo 1 (Bianco, Grigio, Antracite, Nero) Mix Freddo 2 (Bianco, Grigio, Antracite, Cielo) Mix Freddo 3 (Bianco, Grigio, Antracite, Salvia)

9 mm - StrideUp - UGL



Mosaico B  
30x30 cm  
11<sup>7/8</sup>"x11<sup>7/8</sup>"  
(Pcs Box 6)



Mosaico Triangoli Mix\*  
30x30 cm  
11<sup>7/8</sup>"x11<sup>7/8</sup>"  
(Pcs Box 6)

9 mm - StrideUp - UGL



Mosaico Listelli  
30x30 cm  
11<sup>7/8</sup>"x11<sup>7/8</sup>"  
(Pcs Box 6)



Mosaico Listelli Mix\*\*  
30x30 cm  
11<sup>7/8</sup>"x11<sup>7/8</sup>"  
(Pcs Box 6)

<b>BIANCO</b>	NU013MB 032	<b>MIX CALDO 1</b>	NU00MTGC1 042
<b>GRIGIO</b>	NU023MB 032	<b>MIX CALDO 2</b>	NU00MTGC2 042
<b>ANTRACITE</b>	NU033MB 032	<b>MIX FREDDO 1</b>	NU00MTGF1 042
<b>NERO</b>	NU043MB 032	<b>MIX FREDDO 2</b>	NU00MTGF2 042
<b>AVORIO</b>	NU053MB 032	<b>MIX FREDDO 3</b>	NU00MTGF3 042
<b>TORTORA</b>	NU063MB 032		
<b>CIPRIA</b>	NU073MB 032		
<b>MARRONE</b>	NU083MB 032		
<b>SALVIA</b>	NU093MB 032		
<b>CIELO</b>	NU103MB 032		
<b>FIAMMA</b>	NU113MB 032		

<b>BIANCO</b>	NU01ML 027	<b>MIX CALDO 1</b>	NU00MLC1 027
<b>GRIGIO</b>	NU02ML 027	<b>MIX CALDO 2</b>	NU00MLC2 027
<b>ANTRACITE</b>	NU03ML 027	<b>MIX FREDDO 1</b>	NU00MLF1 027
<b>NERO</b>	NU04ML 027	<b>MIX FREDDO 2</b>	NU00MLF2 027
<b>AVORIO</b>	NU05ML 027	<b>MIX FREDDO 3</b>	NU00MLF3 027
<b>TORTORA</b>	NU06ML 027		
<b>CIPRIA</b>	NU07ML 027		
<b>MARRONE</b>	NU08ML 027		
<b>SALVIA</b>	NU09ML 027		
<b>CIELO</b>	NU10ML 027		
<b>FIAMMA</b>	NU11ML 027		



Su rete / Mesh mounted



Tessera  
2x2 3/4"x3/4"



Tessera  
9,8x9,8 3<sup>7/8</sup>"x3<sup>7/8</sup>"



Tessera  
1,5x15 1/2"x6" - 2,5x15 1"x6"  
3x15 1<sup>1/8</sup>"x6" - 4x15 1<sup>3/8</sup>"x6"

\* I Mosaici Triangoli Mix sono formati da 3 colori in posizione casuale. La dimensione e la distribuzione dei triangoli non varia.

Triangoli Mix Mosaics consist of 3 colors in random positions. Size and distribution of the triangles do not change.

Mosaici Triangoli Mix besteht aus 3 Farben in zufälligen Positionen. Die Größe und Verteilung der Dreiecke variiert nicht.

Les Mosaïques Triangles Mix sont composés de 3 couleurs posé au hasard. La dimension et la distribution des triangles ne changent pas.

\*\* I Mosaici Listelli Mix sono formati da 4 colori in posizione casuale. La dimensione e la distribuzione dei listelli non varia.

Listelli Mix mosaics consist of 4 colors in random positions. Size and distribution of the listels do not change.

Mosaici Listelli Mix besteht aus 4 Farben in zufälligen Positionen. Die Größe und Verteilung der Streifen variiert nicht.

Les Mosaïques listelli mix sont composés de 4 couleurs posé au hasard. La dimension et la distribution des listels ne changent pas.

## Color Combinations

Il progetto Nuances è composto da 14 colori e 6 superfici decorative in abbinamento cromatico. L'accostamento tra tonalità e l'unione con i moduli Coccio, offrono infinite possibilità compositive.

The Nuances project consists of 14 colors and 6 decorative surfaces in a wide chromatic matching. The colors combination and the union with the Coccio Decos suggest infinite composition possibilities.

Das Projekt „Nuances“ besteht aus 14 Farben und 6 dekorativen Oberflächen in chromatischer Kombination. Die Kombination der Farben und die Verbindung mit den Coccio-Modulen bieten unendliche Kombinationsmöglichkeiten.

Le projet de Nuances est composé par 14 couleurs et 6 surfaces décoratives en calepinage chromatique. Le calepinage entre tonalités et les décors Coccio proposent énormes possibilités de composition.

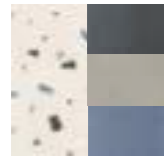

Bianco Coccio / Nero, Tortora, Cielo

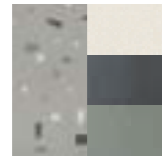

Grigio Coccio / Bianco, Nero, Salvia

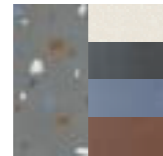

Antracite Coccio / Bianco, Nero, Cielo, Fiamma



Avorio Coccio / Bianco, Cipria, Marrone, Fiamma



Tortora Coccio / Avorio, Cipria, Marrone, Nero

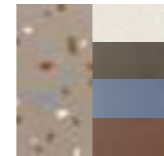

Cipria Coccio / Bianco, Marrone, Cielo, Fiamma



Giada, Bianco, Nero, Grigio



Luce, Bianco, Grigio



Rose, Grigio, Nero



Giada, Cipria, Avorio



Rose, Antracite, Bianco



Luce, Grigio, Salvia



Bianco, Cipria, Marrone



Cipria, Marrone, Fiamma



Bianco, Antracite, Fiamma

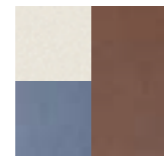

Bianco, Fiamma, Cielo



Cipria, Marrone, Nero



Marrone, Tortora, Avorio, Nero



Bianco, Marrone, Cielo



Bianco, Nero, Tortora, Cielo

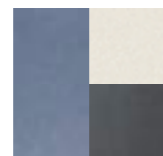

Cielo, Bianco, Nero

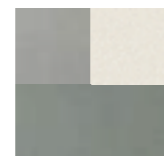

Grigio, Bianco, Salvia

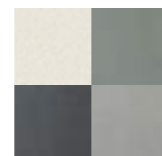

Bianco, Salvia, Nero, Grigio



Cielo, Antracite, Nero

### Stucchi consigliati / Recommended grouts

Colori Colors	Luce	Rose	Giada	Bianco	Grigio	Antracite	Nero	Avorio	Tortora	Cipria	Marrone	Salvia	Cielo	Fiamma
Kerakoll	KK89	KK129	KK50	KK2	KK6	KK8	KK10	KK76	KK66	KK110	KK158	KK8	KK27	KK156
Mapei	70% 131 + 30% 110	90% 100 + 10% 142	80% 181 + 20% 119	111	40% 100 + 60% 112	90% 112 + 10% 114	80% 119 + 20% 110	60% 100 + 40% 110	110	90% 110 + 10% 142	70% 136 + 30% 110	80% 177 + 20% 113	50% 112 + 50% 172	80% 142 + 20% 112

Le tipologie di stucchi riportate nella tabella sono semplici suggerimenti. Prima della posa si raccomanda di eseguire un test di stuccatura per verificarne la compatibilità con la superficie ceramica e le condizioni di utilizzo. / The types of grout listed in the table are simply suggestions. Before installation, it is recommended to perform a grouting test to verify compatibility with the ceramic surface and conditions of use. / Die in der Tabelle aufgeführten Fugenmörteltypen sind lediglich Empfehlungen. Vor dem Verlegen wird empfohlen, einen Fugentest durchzuführen, um die Verträglichkeit mit der Keramikoberfläche und den Einsatzbedingungen zu überprüfen. / Les types de mastics indiqués dans le tableau sont de simples suggestions. Avant la pose, il est recommandé d'effectuer un test de masticage afin de vérifier la compatibilité avec la surface céramique et les conditions d'utilisation.



Listello Tratto Salvia 20x120, Bianco 120x120, Loom Piano 90

Pezzi speciali / Special pieces

9 mm



BIANCO	RealUp	NU0176	009	NU01GT2	223
	Antislip			NU0195I	059
GRIGIO	RealUp	NU0276	009	NU02GT2	223
	Antislip			NU0295I	059
ANTRACITE	RealUp	NU0376	009	NU03GT2	223
	Antislip			NU0395I	059
NERO	RealUp	NU0476	009	NU04GT2	223
	Antislip			NU0495I	059
AVORIO	RealUp	NU0576	009	NU05GT2	223
	Antislip			NU0595I	059
TORTORA	RealUp	NU0676	009	NU06GT2	223
	Antislip			NU0695I	059

Pezzi speciali / Special pieces

9 mm



CIPRIA	RealUp	NU0776	009	NU07GT2	223
	Antislip			NU0795I	059
MARRONE	RealUp	NU0876	009	NU08GT2	223
	Antislip			NU0895I	059
SALVIA	RealUp	NU0976	009	NU09GT2	223
	Antislip				
CIELO	RealUp	NU1076	009	NU10GT2	223
	Antislip				
FIAMMA	RealUp	NU1176	009	NU11GT2	223
	Antislip				
ROSE	RealUp	NU1276	009	NU12GT2	223
	Antislip				
LUCE	RealUp	NU1376	009	NU13GT2	223
	Antislip				
GIADA	RealUp	NU1476	009	NU14GT2	223
	Antislip				



20 mm Open - Pezzi speciali / Special pieces

Per approfondimenti sui pezzi speciali e tutti gli accessori per esterno 20mm scarica la scheda tecnica oppure consultare il nostro sito e il catalogo Open.

For further information on special pieces and all 20mm outdoor accessories download the technical data sheet or consult our website and the Open catalog.

Für weitere Informationen zu Sonderteilen und dem gesamten 20mm Outdoor-Zubehör laden Sie das technische Datenblatt herunter oder besuchen Sie unsere Website und den Open-Katalog.

Pour approfondissements sur les pièces de finition et accessoires pour extérieurs en 20mm merci de télécharger la fiche technique ou bien consulter notre site web et le catalogue OPEN.



Nuances Antracite 120x280x0,6, 60x120 20 mm

Imballi / Packing

				PCS / BOX	M <sup>2</sup> / BOX	KG / BOX	BOX / PALLET	M <sup>2</sup> / PALLET	KG / PALLET
	120x120 cm - 47 <sup>1/4</sup> "x47 <sup>1/4</sup> "	Thick 9 mm	StrideUp	PZ / PCS 02	M <sup>2</sup> 2,88	KG 57,13	PZ / PCS 18	M <sup>2</sup> 51,84	KG 1.084,48
	60x120 cm - 23 <sup>1/2</sup> "x47 <sup>1/4</sup> "	Thick 9 mm	StrideUp	PZ / PCS 02	M <sup>2</sup> 1,44	KG 28,12	PZ / PCS 36	M <sup>2</sup> 51,84	KG 1.052,60
	60x120 cm - 23 <sup>1/2</sup> "x47 <sup>1/4</sup> "	Thick 9 mm	Antislip	PZ / PCS 02	M <sup>2</sup> 1,44	KG 28,96	PZ / PCS 36	M <sup>2</sup> 51,84	KG 1.062,77
	Ribbed 60x120 cm - 23 <sup>1/2</sup> "x47 <sup>1/4</sup> "	Thick 9 mm	Naturale	PZ / PCS 02	M <sup>2</sup> 1,44	KG 27,88	PZ / PCS 36	M <sup>2</sup> 51,84	KG 1.023,71
	Coccio 60x120 cm - 23 <sup>1/2</sup> "x47 <sup>1/4</sup> "	Thick 9 mm	StrideUp	PZ / PCS 02	M <sup>2</sup> 1,44	KG 28,12	PZ / PCS 36	M <sup>2</sup> 51,84	KG 1.032,32
	OPEN 60x120 cm - 23 <sup>1/2</sup> "x47 <sup>1/4</sup> "	Thick 20 mm	Antislip	PZ / PCS 01	M <sup>2</sup> 0,72	KG 32,34	PZ / PCS 36	M <sup>2</sup> 25,92	KG 1.184,42
	80x80 cm - 31 <sup>1/2</sup> "x31 <sup>1/2</sup> "	Thick 9 mm	StrideUp	PZ / PCS 02	M <sup>2</sup> 1,28	KG 25,32	PZ / PCS 42	M <sup>2</sup> 53,76	KG 1.083,60
	Coccio 80x80 cm - 31 <sup>1/2</sup> "x31 <sup>1/2</sup> "	Thick 9 mm	StrideUp	PZ / PCS 02	M <sup>2</sup> 1,28	KG 24,54	PZ / PCS 42	M <sup>2</sup> 53,76	KG 1.050,84
	60x60 cm - 23 <sup>1/2</sup> "x23 <sup>1/2</sup> "	Thick 9 mm	StrideUp	PZ / PCS 04	M <sup>2</sup> 1,44	KG 28,12	PZ / PCS 30	M <sup>2</sup> 43,20	KG 863,75
	30x60 cm - 11 <sup>7/8</sup> "x23 <sup>1/2</sup> "	Thick 9 mm	StrideUp	PZ / PCS 08	M <sup>2</sup> 1,44	KG 27,98	PZ / PCS 32	M <sup>2</sup> 46,08	KG 915,61
	Foliage 60x120 cm - 23 <sup>1/2</sup> "x47 <sup>1/4</sup> "	Thick 9 mm	Naturale	PZ / PCS 02	M <sup>2</sup> 1,44	KG 28,28	PZ / PCS 15	M <sup>2</sup> 21,61	KG 444,20
	Triangolo 60x120 cm - 23 <sup>1/2</sup> "x47 <sup>1/4</sup> "	Thick 9 mm	Naturale	PZ / PCS 03	M <sup>2</sup> 2,16	KG 44,00	PZ / PCS 15	M <sup>2</sup> 32,40	KG 680,00
	Botanica 60x120 cm - 23 <sup>1/2</sup> "x47 <sup>1/4</sup> "	Thick 9 mm	Naturale	PZ / PCS 02	M <sup>2</sup> 1,44	KG 30,00	PZ / PCS 20	M <sup>2</sup> 28,81	KG 620,00
	Listello Tratto 20x120 cm - 8"x47 <sup>1/4</sup> "	Thick 6 mm	Naturale	PZ / PCS 06	M <sup>2</sup> 1,44	KG 19,84	PZ / PCS 30	M <sup>2</sup> 43,20	KG 615,26
	Muretto 30x30 cm - 11 <sup>7/8</sup> "x11 <sup>7/8</sup> "	Thick 9 mm	StrideUp / Naturale	PZ / PCS 06	M <sup>2</sup> 0,54	KG 9,88	PZ / PCS 60	M <sup>2</sup> 32,40	KG 619,92
	Muretto 30x30 cm - 11 <sup>7/8</sup> "x11 <sup>7/8</sup> "	Thick 6 mm	StrideUp / Naturale	PZ / PCS 06	M <sup>2</sup> 0,54	KG 7,24	PZ / PCS 60	M <sup>2</sup> 32,40	KG 454,52
	Mosaico Ovale / Ovale Mix 19,5x37 cm - 4"x14 <sup>5/8</sup> "	Thick 9 mm	StrideUp	PZ / PCS 06	M <sup>2</sup> 0,43	KG 9,28	PZ / PCS 60	M <sup>2</sup> 25,92	KG 576,92
	Mosaico Listelli / Listelli Mix 30x30 cm - 11 <sup>7/8</sup> "x11 <sup>7/8</sup> "	Thick 9 mm	StrideUp	PZ / PCS 06	M <sup>2</sup> 0,54	KG 10,63	PZ / PCS 60	M <sup>2</sup> 32,40	KG 658,28
	Mosaico Triangoli 30x30 cm - 11 <sup>7/8</sup> "x11 <sup>7/8</sup> "	Thick 9 mm	StrideUp	PZ / PCS 06	M <sup>2</sup> 0,54	KG 11,53	PZ / PCS 60	M <sup>2</sup> 32,40	KG 712,28
	Mosaico A 30x30 cm - 11 <sup>7/8</sup> "x11 <sup>7/8</sup> "	Thick 9 mm	StrideUp	PZ / PCS 12	M <sup>2</sup> 1,08	KG 21,03	PZ / PCS 30	M <sup>2</sup> 32,40	KG 651,17
	Mosaico B 30x30 cm - 11 <sup>7/8</sup> "x11 <sup>7/8</sup> "	Thick 9 mm	StrideUp	PZ / PCS 06	M <sup>2</sup> 0,54	KG 9,64	PZ / PCS 60	M <sup>2</sup> 32,40	KG 598,52
	Wild Decoro 60x120 cm - 23 <sup>1/2</sup> "x47 <sup>1/4</sup> "	Thick 9 mm	Naturale	PZ / PCS 2	M <sup>2</sup> 1,44	KG 28,32	PZ / PCS 20	M <sup>2</sup> 28,81	KG 586,40
	Eden Decoro 60x120 cm - 23 <sup>1/2</sup> "x47 <sup>1/4</sup> "	Thick 9 mm	Naturale	PZ / PCS 2	M <sup>2</sup> 1,44	KG 28,09	PZ / PCS 36	M <sup>2</sup> 51,84	KG 1.029,11

Imballi Mega / Mega Packing

	DESCRIZIONE IMBALLO / PACKAGING DESCRIPTION	MQ / KG LASTRA / SLAB	IMBALLO PIENO / FULL PACKAGING	IMBALLO VUOTO / EMPTY PACKAGING
	CASSA / CRATE L 145 x P 292 x H 35	MQ 3,36	MQ 67,20	
		KG 48,60	KG 1062,00	KG 100,00
	CAVALLETTO / A-FRAME L 75 x P 285 x H 153	MQ 3,36	MQ 147,84	
		KG 48,60	KG 2318,40	KG 180,00
	CASSA LIGHT / LIGHT CRATE L 145 x P 292 x H 27	MQ 3,36	MQ 30,24	
		KG 48,60	KG 527,40	KG 90,00
			PZ 1 / 9	

**320 Wood Effect**

322 Essence Select

332 Essence

342 Allure

350 Alnus



# Essence Select

Gres porcellanato - Rettificato / Porcelain Stoneware - Rectified  
 Feinsteinzeug - Kalibriert / Gres Cerame - Rectifié

New Innovative  
 Technology

RealUp®



Download  
 Catalogue

Conforming to Standards  
 EN 14411 ISO 13006 APPENDICE G GRUPPO BIa UGL CON Ev ≤ 0,5%

Caratteristiche tecniche  
 Technical features

BENDING STRENGTH	FROST RESISTANCE	CHEMICAL RESISTANCE	STAIN RESISTANCE	
ANSI A326.3 > 0,42	R10 / A+B	R11 / A+B+C	TRAFFICO INTENSO HEAVY TRAFFIC	V2 MODERATE
Realup Antislip	RealUp	Antislip	Realup Antislip	All Colours

Formati  
 Sizes

	9 mm
SUPERFICIE SURFACE	20x120 cm 8"x47 1/4"
RealUp	■
Antislip	■

Colori  
 Colours

Chiaro	Miele	Oro	Mandorla

Superficie  
 Surface finishes

RealUp	Antislip

Oro 20x120, Listello Tratto Oro 20x120, Nuances Giada 120x280x0,6



Chiaro 20x120, Listello Tratto Chiaro 20x120, Nuances Bianco, Giada 120x280x0,6



Miele 20x120, Listello Tratto Miele 20x120, I Cementi Beige 120x120, 120x280x0,6, Listello Tratto Beige 20x120, Loom Piano 140

Chiaro



Miele



Oro



Mandorla



■ 9 mm - RealUp

□  
20x120 cm  
8"x47<sup>1/4</sup>"

RealUp	UGL	CHIARO	SC01EA	■ 051
		MIELE	SC02EA	■ 051
Antislip	UGL	CHIARO	SC01EAA	■ 051
		MIELE	SC02EAA	■ 051

■ 9 mm - RealUp

□  
20x120 cm  
8"x47<sup>1/4</sup>"

RealUp	UGL	ORO	SC03EA	■ 051
		MANDORLA	SC04EA	■ 051
Antislip	UGL	ORO	SC03EAA	■ 051
		MANDORLA	SC04EAA	■ 051

# Listello Tratto

20x120

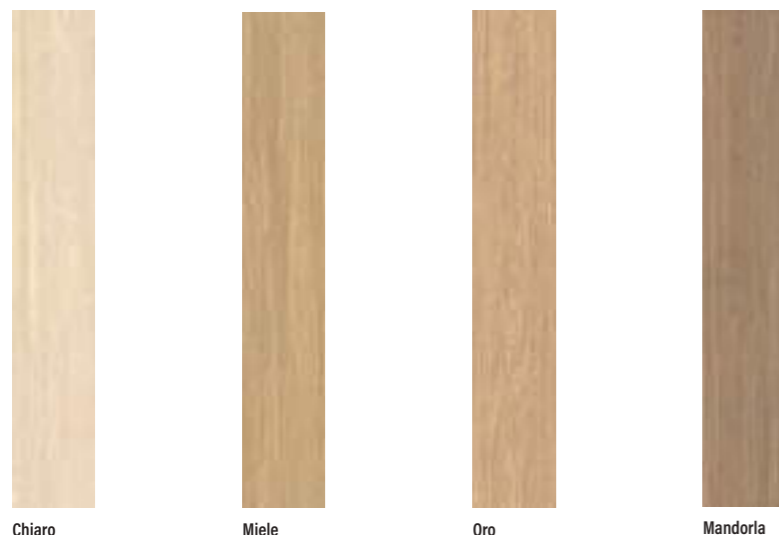

Chiaro

Miele

Oro

Mandorla

9 mm - RealUp - UGL

Listello Tratto  
20x120 cm  
8"x47"<sup>1/4</sup>"  
(Pcs Box 6)

CHIARO	SC01LT9	064
MIELE	SC02LT9	064
ORO	SC03LT9	064
MANDORLA	SC04LT9	064



Su rete / Mesh mounted



Tessera  
2,5x120 1"x47"<sup>1/4</sup>"

Listello Tratto

## Pezzi speciali / Special pieces

9 mm



Battiscopa

6,5x120 cm

2<sup>1/2</sup>"x47"<sup>1/4</sup>"

(Pcs Box 8)



Gradone con Toro

120x33x4 cm

47<sup>1/4</sup>"x13<sup>1/8</sup>"x4"

(Pcs Box 2)



Elemento "L" Incollato Antislip

4,5x10,5x60 cm

1<sup>3/4</sup>"x 6<sup>1/2</sup>"x23<sup>1/2</sup>"

(Pcs Box 2)

CHIARO	RealUp	SC01BT2	018	SC01GT2	223
	Antislip			SC0189I	081
MIELE	RealUp	SC02BT2	018	SC02GT2	223
	Antislip			SC0289I	081
ORO	RealUp	SC03BT2	018	SC03GT2	223
	Antislip			SC0389I	081
MANDORLA	RealUp	SC04BT2	018	SC04GT2	223
	Antislip			SC0489I	081

## Imballi / Packing

				PCS / BOX	M <sup>2</sup> / BOX	KG / BOX	BOX / PALLET	M <sup>2</sup> / PALLET	KG / PALLET
	20x120 cm - 8"x47" <sup>1/4</sup> "	Thick 9 mm	RealUp	PZ / PCS 06	M <sup>2</sup> 1,44	KG 28,16	PZ / PCS 30	M <sup>2</sup> 43,20	KG 888,92
	20x120 cm - 8"x47" <sup>1/4</sup> "	Thick 9 mm	Antislip	PZ / PCS 06	M <sup>2</sup> 1,44	KG 28,07	PZ / PCS 30	M <sup>2</sup> 43,20	KG 862,28
	Listello Tratto 20x120 cm - 8"x47" <sup>1/4</sup> "	Thick 9 mm	RealUp	PZ / PCS 06	M <sup>2</sup> 1,44	KG 26,07	PZ / PCS 28	M <sup>2</sup> 40,32	KG 749,96

## Stucchi consigliati / Recommended grouts

Colori Colors	Chiaro	Miele	Oro	Mandorla
Kerakoll	KK64	KK79	KK152	KK92
Mapei	70% 110 + 30% 131	90% 138 + 10% 112	70% 132 + 30% 134	134

Le tipologie di stucchi riportate nella tabella sono semplici suggerimenti. Prima della posa si raccomanda di eseguire un test di stuccatura per verificarne la compatibilità con la superficie ceramica e le condizioni di utilizzo. / The types of grout listed in the table are simply suggestions. Before installation, it is recommended to perform a grouting test to verify compatibility with the ceramic surface and conditions of use. / Die in der Tabelle aufgeführten Fugenmörteltypen sind lediglich Empfehlungen. Vor dem Verlegen wird empfohlen, einen Fugentest durchzuführen, um die Verträglichkeit mit der Keramikoberfläche und den Einsatzbedingungen zu überprüfen. / Les types de mastics indiqués dans le tableau sont de simples suggestions. Avant la pose, il est recommandé d'effectuer un test de masticage afin de vérifier la compatibilité avec la surface céramique et les conditions d'utilisation.

Pag. 415: approfondimenti calibri specifici / Pag. 415: further information on specific working sizes / S. 415: Vertiefungen über spezifische Werkmaße / Pag. 415 : approfondissements dimensions de fabrication spécifiques



Lisca Taupe 9x50

# Essence

Gres porcellanato - Rettificato / Porcelain Stoneware - Rectified  
Feinsteinzeug - Kalibriert / Gres Cerame - Rectifié

Conforming to Standards  
EN 14411 ISO 13006 APPENDICE G GRUPPO BIa UGL CON Ev ≤ 0,5%

New Innovative  
Technology

RealUp®



Download  
Catalogue

Caratteristiche tecniche  
Technical features

BENDING STRENGTH	FROST RESISTANCE	CHEMICAL RESISTANCE	STAIN RESISTANCE	
ANSI A326.3 > 0,42	R10 / A+B	R11 / A+B+C	TRAFFICO INTENSO HEAVY TRAFFIC	V2 MODERATE
Realup Antislip	RealUp	Antislip	Realup Antislip	All Colours

Formati  
Sizes

	9 mm	
SUPERFICIE SURFACE	20x120 cm 8"x47 <sup>1/4"</sup>	Lisca 9x50 cm 3 <sup>1/2"</sup> x19 <sup>3/4"</sup>
RealUp	■	■
Antislip	■	

Colori  
Colours

Gold	Warm	Natural	Taupe

Superficie  
Surface finishes

RealUp	Antislip



Warm 20x120, Nuances Fiamma 120x280x0,6



Natural 20x120, Nuances Cipria 120x280x0,6, Muretto Cipria 30x30

Gold



Warm



Natural



Taupe



9 mm - RealUp

20x120 cm  
8"x47<sup>1/4"</sup>

Lisca\*  
9x50 cm  
3<sup>1/2"</sup>x19<sup>3/4"</sup>

RealUp	UGL	<b>GOLD</b>	EE02EA 051	EE12L50 140
		<b>WARM</b>	EE03EA 051	EE13L50 140
Antislip	UGL	<b>GOLD</b>	EE02EAA 051	
		<b>WARM</b>	EE03EAA 051	

9 mm - RealUp

20x120 cm  
8"x47<sup>1/4"</sup>

Lisca\*  
9x50 cm  
3<sup>1/2"</sup>x19<sup>3/4"</sup>

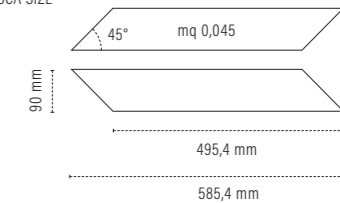

RealUp	UGL	<b>NATURAL</b>	EE01EA 051	EE11L50 140
		<b>TAUPE</b>	EE04EA 051	EE14L50 140
Antislip	UGL	<b>NATURAL</b>	EE01EAA 051	
		<b>TAUPE</b>	EE04EAA 051	

\* LISCA SIZE





Pezzi speciali / Special pieces

		9 mm			
		Battiscopa	Gradone con Toro	Elemento "L" Incollato Antislip	Gradino
		6,5x120 cm 2 <sup>1/2</sup> "x47 <sup>1/4</sup> " (Pcs Box 8)	120x33x4 cm 47 <sup>1/4</sup> "x13 <sup>1/4</sup> "x1 <sup>3/4</sup> " (Pcs Box 2)	4,5x10,5x60 cm 1 <sup>3/4</sup> "x 6 <sup>1/2</sup> "x23 <sup>1/2</sup> " (Pcs Box 2)	120x30 cm 47 <sup>1/4</sup> "x11 <sup>7/8</sup> " (Pcs Box 4)
GOLD	RealUp	EE02BT2 ■ 018	EE02GT2 ■ 223		EE02GR ■ 099
	Antislip			EE0289I ■ 081	
NATURAL	RealUp	EE01BT2 ■ 018	EE01GT2 ■ 223		EE01GR ■ 099
	Antislip			EE0189I ■ 081	
WARM	RealUp	EE03BT2 ■ 018	EE03GT2 ■ 223		EE03GR ■ 099
	Antislip			EE0389I ■ 081	
TAUPE	RealUp	EE04BT2 ■ 018	EE04GT2 ■ 223		EE04GR ■ 099
	Antislip			EE0489I ■ 081	

		PCS / BOX	M <sup>2</sup> / BOX	KG / BOX	BOX / PALLET	M <sup>2</sup> / PALLET	KG / PALLET		
	20x120 cm - 8"x47 <sup>1/4</sup> "	Thick 9 mm	RealUp	PZ / PCS 06	M <sup>2</sup> 1,44	KG 28,78	PZ / PCS 30	M <sup>2</sup> 43,20	KG 883,40
	20x120 cm - 8"x47 <sup>1/4</sup> "	Thick 9 mm	Antislip	PZ / PCS 06	M <sup>2</sup> 1,44	KG 28,93	PZ / PCS 30	M <sup>2</sup> 43,20	KG 887,90
	Lisca 9x50 cm - 3 <sup>1/2</sup> "x19 <sup>3/4</sup> "	Thick 9 mm	RealUp	PZ / PCS 14	M <sup>2</sup> 0,63	KG 12,66	PZ / PCS 50	M <sup>2</sup> 31,50	KG 653,00

Imballi Mega / Mega Packing

		DESCRIZIONE IMBALLO PACKAGING DESCRIPTION	MQ / KG LASTRA / SLAB	IMBALLO PIENO FULL PACKAGING	IMBALLO VUOTO EMPTY PACKAGING
	120x280x0,6 cm 47 <sup>1/4</sup> "x110 <sup>1/4</sup> "x1/4"	CASSA / CRATE L 145 x P 292 x H 35	MQ 3,36	MQ 6220	
			KG 48,60	KG 1062,00	KG 100,00
		CAVALLETTO / A-FRAME L 75 x P 285 x H 153	MQ 3,36	MQ 14784	
			KG 48,60	KG 2318,40	KG 180,00
	120x280x0,6 cm 47 <sup>1/4</sup> "x110 <sup>1/4</sup> "x1/4"	CASSA LIGHT / LIGHT CRATE L 145 x P 292 x H 27	MQ 3,36	MQ 30,24	
			KG 48,60	KG 527,40	KG 90,00
				PZ 1 / 9	

Stucchi consigliati / Recommended grouts

Colori Colors	Gold	Warm	Natural	Taupe
Kerakoll	KK152	KK92	KK109	KK157
Mapei	133	70% 138 + 30% 112	80% 110 + 20% 137	90% 133 + 10% 113

Le tipologie di stucchi riportate nella tabella sono semplici suggerimenti. Prima della posa si raccomanda di eseguire un test di stuccatura per verificarne la compatibilità con la superficie ceramica e le condizioni di utilizzo. / The types of grout listed in the table are simply suggestions. Before installation, it is recommended to perform a grouting test to verify compatibility with the ceramic surface and conditions of use. / Die in der Tabelle aufgeführten Fugenmörteltypen sind lediglich Empfehlungen. Vor dem Verlegen wird empfohlen, einen Fugentest durchzuführen, um die Verträglichkeit mit der Keramikoberfläche und den Einsatzbedingungen zu überprüfen. / Les types de mastics indiqués dans le tableau sont de simples suggestions. Avant la pose, il est recommandé d'effectuer un test de masticage afin de vérifier la compatibilité avec la surface céramique et les conditions d'utilisation.





# Allure

Gres porcellanato - Rettificato / Porcelain Stoneware - Rectified  
Feinsteinzeug - Kalibriert / Gres Cerame - Rectifié

Conforming to Standards  
EN 14411 ISO 13006 APPENDICE G GRUPPO BIa UGL CON Ev ≤ 0,5%



Download  
Catalogue

Caratteristiche tecniche  
Technical features



BENDING  
STRENGTH



ANSI A326.3 > 0,42

Naturale / Matte



FROST  
RESISTANCE



TRAFFICO INTENSO  
HEAVY TRAFFIC

Naturale / Matte



CHEMICAL  
RESISTANCE



V3 HIGH

All Colours



STAIN  
RESISTANCE

Formati  
Sizes

SUPERFICIE  
SURFACE

Naturale / Matte

9 mm

20x120 cm  
8"x47"<sup>1/4"</sup>

Colori  
Colours



Rovere Blanc



Rovere Amande



Rovere Naturel



Olmo Ambré



Olmo Fumé



Noce Brun

Superficie  
Surface finishes



Naturale  
Matte



Trait Listola 120x20x120, Olmo Fumé 20x120, Ceppo di Gré Grey 120x280x0,6

Rovere Blanc



Rovere Amande



Rovere Naturel



Olmo Ambré



■ 9 mm

20x120 cm  
8"x47 1/4"

Naturale / Matte	UGL	ROVERE BLANC	AR01EA	051
		ROVERE AMANDE	AR02EA	051

■ 9 mm

20x120 cm  
8"x47 1/4"

Naturale / Matte	UGL	ROVERE NATUREL	AR03EA	051
		OLMO AMBRÉ	AR04EA	051

# Olmo Fumé



# Noce Brun



# Listello Tratto Allure

20x120



Blanc / Amande / Naturel

# Listello Tratto Mix

20x120



Fumé / Brun / Silver Grain Grey / Silver Grain Taupe / Ceppo di Grè Grey

9 mm

Listello Tratto  
20x120 cm  
8"x47 1/4"  
(Pcs Box 4)

Naturale / Matte	UGL	ALLURE	AR00LT	045
Naturale / Matte	UGL	MIX	AR00LTM	045

## Pezzi speciali / Special pieces

9 mm



Battiscopa

6,5x120 cm  
2 1/2"x47 1/4"  
(Pcs Box 8)



Gradone con Toro

120x33x4 cm  
47 1/4"x13 1/4"  
(Pcs Box 2)

9 mm



Battiscopa

6,5x120 cm  
2 1/2"x47 1/4"  
(Pcs Box 8)



Gradone con Toro

120x33x4 cm  
47 1/4"x13 1/4"  
(Pcs Box 2)

ROVERE BLANC	Naturale / Matte	AR01BT2	018	AR01GT2	223	OLMO AMBRÉ	Naturale / Matte	AR04BT2	018	AR04GT2	223
ROVERE AMANDE	Naturale / Matte	AR02BT2	018	AR02GT2	223	OLMO FUMÉ	Naturale / Matte	AR05BT2	018	AR05GT2	223
ROVERE NATUREL	Naturale / Matte	AR03BT2	018	AR03GT2	223	NOCE BRUN	Naturale / Matte	AR06BT2	018	AR06GT2	223

## Imballi / Packing



	20x120 cm - 8"x47 1/4"	Thick 9 mm	Naturale	PCS / BOX	M² / BOX	KG / BOX	BOX / PALLET	M² / PALLET	KG / PALLET
				PZ / PCS 06	M² 1,44	KG 30,00	PZ / PCS 30	M² 43,20	KG 920,33
	Trait Listello 20x120 cm - 8"x47 1/4"	Thick 9 mm	Naturale	PZ / PCS 04	M² 0,96	KG 19,00	PZ / PCS 30	M² 28,80	KG 590,00

## Stucchi consigliati / Recommended grouts

Colori / Colors	Rovere Blanc	Rovere Amande	Rovere Naturel	Olmo Ambré	Olmo Fumé	Noce Brun
Kerakoll	KK79	KK79	KK89	KK152	KK92	KK158
Mapei	110	50% 137 + 50% 112	50% 100 + 50% 137	70% 137 + 20% 136 + 10% 112	50% 137 + 50% 112	114

Le tipologie di stucchi riportate nella tabella sono semplici suggerimenti. Prima della posa si raccomanda di eseguire un test di stuccatura per verificarne la compatibilità con la superficie ceramica e le condizioni di utilizzo. / The types of grout listed in the table are simply suggestions. Before installation, it is recommended to perform a grouting test to verify compatibility with the ceramic surface and conditions of use. / Die in der Tabelle aufgeführten Fugenmörteltypen sind lediglich Empfehlungen. Vor dem Verlegen wird empfohlen, einen Fugentest durchzuführen, um die Verträglichkeit mit der Keramikoberfläche und den Einsatzbedingungen zu überprüfen. / Les types de mortiers indiqués dans le tableau sont de simples suggestions. Avant la pose, il est recommandé d'effectuer un test de masticage afin de vérifier la compatibilité avec la surface céramique et les conditions d'utilisation.

Pag. 415: approfondimenti calibri specifici / Pag. 415: further information on specific working sizes / S. 415: Vertiefungen über spezifische Werkmaße / Pag. 415 : approfondissements dimensions de fabrication spécifiques

Naturale / Matte	UGL	OLMO FUMÉ	AR05EA	051
		NOCE BRUN	AR06EA	051



# Alnus









Gres porcellanato - Rettificato / Porcelain Stoneware - Rectified  
 Feinsteinzeug - Kalibriert / Gres Cerame - Rectifié

Conforming to Standards  
 EN 14411 ISO 13006 APPENDICE G GRUPPO BIa UGL CON Ev ≤ 0,5%



Download  
 Catalogue

Caratteristiche tecniche  
 Technical features

				
BENDING STRENGTH	FROST RESISTANCE	CHEMICAL RESISTANCE	STAIN RESISTANCE	SINGLE THICKNESS
				
ANSI A326.3 > 0,42	TRAFFICO INTENSO HEAVY TRAFFIC	V2 MODERATE		
Naturale / Matte	Naturale / Matte	All Colours		

Formati  
 Sizes

9 mm

SUPERFICIE  
 SURFACE

20x120 cm  
 8"x47 1/4"

Naturale / Matte

Colori  
 Colours

					
Puro	Vaniglia	Neutro	Plumbeo	Mandoria	Terra

Superficie  
 Surface finishes



Naturale  
 Matte

Mandoria 20x120, Nordic Stone Islanda 80x160

Puro



Vaniglia



Neutro



Plumbeo



■ 9 mm

20x120 cm  
8"x47 1/4"

Naturale / Matte	UGL	PURO	AU01EA	■ 051
		VANIGLIA	AU02EA	■ 051

■ 9 mm

20x120 cm  
8"x47 1/4"

Naturale / Matte	UGL	NEUTRO	AU03EA	■ 051
		PLUMBEO	AU04EA	■ 051

Mandorla



Terra



Mosaico Tarsie

14x28



Mix C (Vaniglia e Neutro)

9 mm  
Naturale / Matte - UGL

Mosaico Tarsie  
14x28 cm  
5 1/2" x 11"  
(Pcs Box 8)

MIX C AU23MS 024

SCHEMI DI POSA / INSTALLATION SYSTEMS

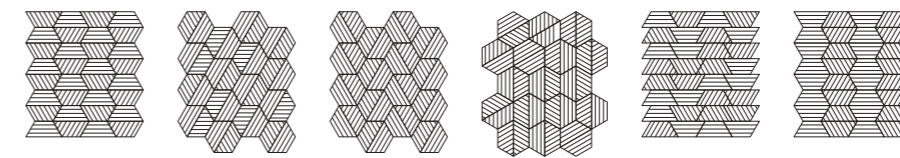

Su rete / Mesh mounted  
Mosaico Tarsie

Pezzi speciali / Special pieces

9 mm

Battiscopa

6,5x120 cm  
2 1/2" x 47 1/4"  
(Pcs Box 8)



Gradone con Toro

120x33x4 cm  
47 1/4" x 13" x 1 3/4"  
(Pcs Box 2)

9 mm

Battiscopa

6,5x120 cm  
2 1/2" x 47 1/4"  
(Pcs Box 8)



Gradone con Toro

120x33x4 cm  
47 1/4" x 13" x 1 3/4"  
(Pcs Box 2)

<b>PURO</b>	Naturale / Matte	AU01BT2 018	AU01GT2 223	<b>PLUMBEO</b>	Naturale / Matte	AU04BT2 018	AU04GT2 223
<b>VANIGLIA</b>	Naturale / Matte	AU02BT2 018	AU02GT2 223	<b>MANDORLA</b>	Naturale / Matte	AU05BT2 018	AU05GT2 223
<b>NEUTRO</b>	Naturale / Matte	AU03BT2 018	AU03GT2 223	<b>TERRA</b>	Naturale / Matte	AU06BT2 018	AU06GT2 223

Imballi / Packing

				PCS / BOX	M <sup>2</sup> / BOX	KG / BOX	BOX / PALLET	M <sup>2</sup> / PALLET	KG / PALLET
	20x120 cm - 8" x 47 1/4"	Thick 9 mm	Naturale	PZ / PCS 06	M <sup>2</sup> 1,44	KG 30,81		M <sup>2</sup> 43,20	KG 944,30
	Mosaico Tarsie 14x28 cm - 5 1/2" x 11"	Thick 9 mm	Naturale	PZ / PCS 08	M <sup>2</sup> 0,20	KG 4,40		M <sup>2</sup> 27,05	KG 592,00

Stucchi consigliati / Recommended grouts

Colori Colors	Puro	Vaniglia	Neutro	Plumbeo	Mandorla	Terra
<b>Kerakoll</b>	KK64	KK151	KK151	KK81	KK92	KK93
<b>Mapei</b>	111	60% 130 + 40% 112	70% 110 + 30% 112	112	113	80% 113 + 20% 114

Le tipologie di stucchi riportate nella tabella sono semplici suggerimenti. Prima della posa si raccomanda di eseguire un test di stuccatura per verificarne la compatibilità con la superficie ceramica e le condizioni di utilizzo. / The types of grout listed in the table are simply suggestions. Before installation, it is recommended to perform a grouting test to verify compatibility with the ceramic surface and conditions of use. / Die in der Tabelle aufgeführten Fugenmörteltypen sind lediglich Empfehlungen. Vor dem Verlegen wird empfohlen, einen Fugentest durchzuführen, um die Verträglichkeit mit der Keramikoberfläche und den Einsatzbedingungen zu überprüfen. / Les types de mastics indiqués dans le tableau sont de simples suggestions. Avant la pose, il est recommandé d'effectuer un test de masticage afin de vérifier la compatibilité avec la surface céramique et les conditions d'utilisation.

Pag. 415: approfondimenti calibri specifici / Pag. 415: further information on specific working sizes / S. 415: Vertiefungen über spezifische Werkmaße / Pag. 415 : approfondissements dimensions de fabrication spécifiques

9 mm

20x120 cm  
8" x 47 1/4"

Naturale / Matte	UGL	MANDORLA	AU05EA 051
		TERRA	AU06EA 051

LOOM  
BY ITALGRANITI

- 358 Gallery
- 364 Piano
- 367 Piano<sup>angle</sup>
- 367 Cilindro
- 368 Piana
- 368 Quadra
- 368 Linea
- 369 Tratto
- 369 Flusso
- 369 Piatto
- 379 Basins & mirrors
- 371 Price list

LOOM  
BY ITALGRANITI



Loom Piano 140, Nuances Avorio, Noce Canaletto, Marble Touch Calacatta Top, Nuances Salvia



Loom Cilindro 50, Nuances Marrone, Muretto Marrone



Loom Linea .2, Nuances Bianco, Calcis Avorio, Calcis Visone



Loom Piano Angle 110, Nuances Marrone

## piano .70

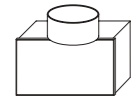
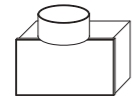
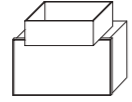
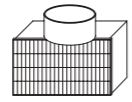
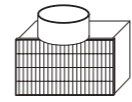
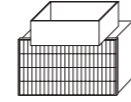
70x41x41 cm  
27<sup>1</sup>/<sub>2</sub>"x16<sup>1</sup>/<sub>8</sub>"x16<sup>1</sup>/<sub>8</sub>"**PIANO 70 DX**  
per 1 ciotola tonda  
for 1 round basin  
P70CTDX**PIANO 70 SX**  
per 1 ciotola tonda  
for 1 round basin  
P70CTSX**PIANO 70**  
per 1 ciotola rettangolare  
for 1 rectangular basin  
P70CRCE**PIANO 70 DX**  
per 1 ciotola tonda  
for 1 round basin  
P70CTDXM**PIANO 70 SX**  
per 1 ciotola tonda  
for 1 round basin  
P70CTSXM**PIANO 70**  
per 1 ciotola rettangolare  
for 1 rectangular basin  
P70CRCEM

## piano .70 (Muretto)

70x41x41 cm  
27<sup>1</sup>/<sub>2</sub>"x16<sup>1</sup>/<sub>8</sub>"x16<sup>1</sup>/<sub>8</sub>"

## piano .90

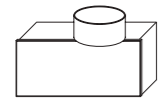
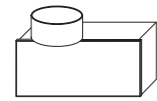
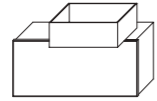
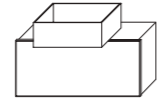
91x41x41 cm  
35<sup>7</sup>/<sub>8</sub>"x16<sup>1</sup>/<sub>8</sub>"x16<sup>1</sup>/<sub>8</sub>"**PIANO 90 DX**  
per 1 ciotola tonda  
for 1 round basin  
P90CTDX**PIANO 90 SX**  
per 1 ciotola tonda  
for 1 round basin  
P90CTSX**PIANO 90 DX**  
per 1 ciotola rettangolare  
for 1 rectangular basin  
P90CRDX**PIANO 90 SX**  
per 1 ciotola rettangolare  
for 1 rectangular basin  
P90CRSX

## piano. 90 (Muretto)

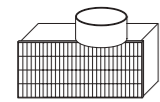
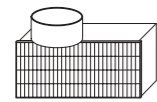
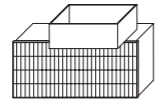
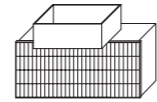
91x41x41 cm  
35<sup>7</sup>/<sub>8</sub>"x16<sup>1</sup>/<sub>8</sub>"x16<sup>1</sup>/<sub>8</sub>"**PIANO 90 DX**  
per 1 ciotola tonda  
for 1 round basin  
P90CTDXM**PIANO 90 SX**  
per 1 ciotola tonda  
for 1 round basin  
P90CTSXM**PIANO 90 DX**  
per 1 ciotola rettangolare  
for 1 rectangular basin  
P90CRDXM**PIANO 90 SX**  
per 1 ciotola rettangolare  
for 1 rectangular basin  
P90CRSXM

## piano .140

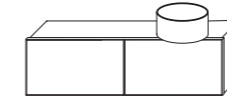
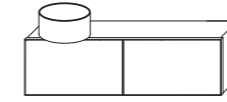
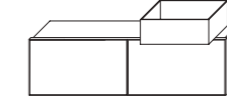
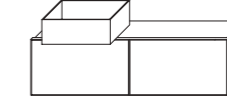
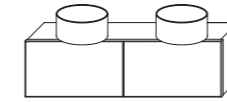
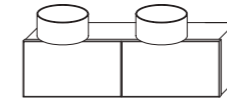
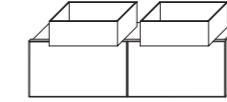
140x41x41 cm  
55<sup>1</sup>/<sub>8</sub>"x16<sup>1</sup>/<sub>8</sub>"x16<sup>1</sup>/<sub>8</sub>"**PIANO DOPPIO 140 DX**  
per 1 ciotola tonda  
for 1 round basin  
PS140CTDX**PIANO DOPPIO 140 SX**  
per 1 ciotola tonda  
for 1 round basin  
PS140CTSX**PIANO DOPPIO 140 DX**  
per 1 ciotola rettangolare  
for 1 rectangular basin  
PS140CRDX**PIANO DOPPIO 140 SX**  
per 1 ciotola rettangolare  
for 1 rectangular basin  
PS140CRSX**PIANO DOPPIO 140 DX**  
per 2 ciotole tonde  
for 2 round basins  
PD140CTDX**PIANO DOPPIO 140 SX**  
per 2 ciotole tonde  
for 2 round basins  
PD140CTSX**PIANO DOPPIO 140**  
per 2 ciotole rettangolari  
for 2 rectangular basins  
PD140CRCE

## piano .140 (Muretto)

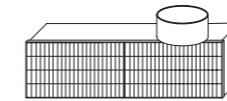
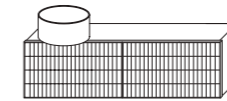
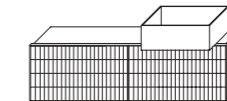
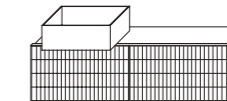
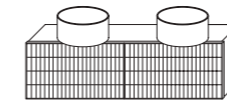
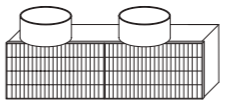
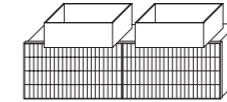
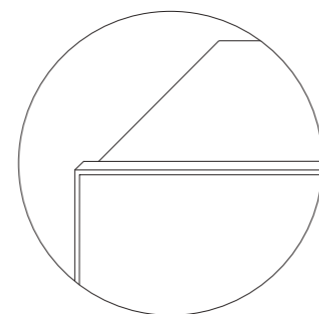
140x41x41 cm  
55<sup>1</sup>/<sub>8</sub>"x16<sup>1</sup>/<sub>8</sub>"x16<sup>1</sup>/<sub>8</sub>"**PIANO DOPPIO 140 DX**  
per 1 ciotola tonda  
for 1 round basin  
PS140CTDXM**PIANO DOPPIO 140 SX**  
per 1 ciotola tonda  
for 1 round basin  
PS140CTSXM**PIANO DOPPIO 140 DX**  
per 1 ciotola rettangolare  
for 1 rectangular basin  
PS140CRDXM**PIANO DOPPIO 140 SX**  
per 1 ciotola rettangolare  
for 1 rectangular basin  
PS140CRSXM**PIANO DOPPIO 140 DX**  
per 2 ciotole tonde  
for 2 round basins  
PD140CTDXM**PIANO DOPPIO 140 SX**  
per 2 ciotole tonde  
for 2 round basins  
PD140CTSXM**PIANO DOPPIO 140**  
per 2 ciotole rettangolari  
for 2 rectangular basins  
PD140CRCEM

Dettaglio piano / Piano detail

Personalizzazione su richiesta in tutti i colori e muretti 6 mm della collezione Mega®. / Customization on request in all 6 mm colors and muretti of the Mega® collection. / Maßanfertigung auf Anfrage in allen Farben und Murretts 6 mm der Kollektionen Mega® erhältlich. / Personnalisation sur demande dans toutes les couleurs et formats mur 6 mm des collections Mega®.

Tutti i modelli sono disponibili anche nella versione Cannettata. / All models are also available in the Cannettata version. / Alle Modelle sind auch in der Version Cannettata erhältlich. / Tous les modèles sont également disponibles dans la version Cannettata.

Codici e misure sono riferite solo al mobile Piano, lavabo escluso. Personalizzazione su richiesta in tutti i colori e muretti 6mm delle collezioni Mega®. / Codes and dimensions refer only to the Piano cabinet, not including the washbasin. Customization on request in all 6 mm colors and muretti of the Mega® collections. / Die Artikelnummern und Maße beziehen sich nur auf den Schrank Piano ohne Waschbecken. Maßanfertigung auf Anfrage in allen Farben und Murretts 6 mm der Kollektionen Mega® erhältlich. / Les codes et mesures se réfèrent uniquement au meuble Piano, sans le lavabo. Personnalisation sur demande dans toutes les couleurs et formats mur 6 mm des collections Mega®.

## piano .180

182x41x 41 cm  
71<sup>5/8</sup>"x16<sup>1/8</sup>"x16<sup>1/8</sup>"

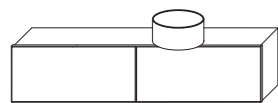

**PIANO DOPPIO 180 DX**  
per 1 ciotola tonda  
for 1 round basin  
PS180CTDX

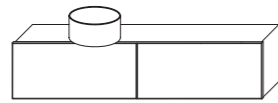

**PIANO DOPPIO 180 SX**  
per 1 ciotola tonda  
for 1 round basin  
PS180CTSX

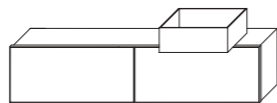

**PIANO DOPPIO 180 DX**  
per 1 ciotola rettangolare  
for 1 rectangular basin  
PS180CRDX

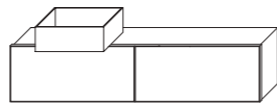

**PIANO DOPPIO 180 SX**  
per 1 ciotola rettangolare  
for 1 rectangular basin  
PS180CRSX

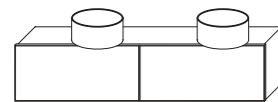

**PIANO DOPPIO 180 DX**  
per 2 ciotole tonde  
for 2 round basins  
PD180CTDX

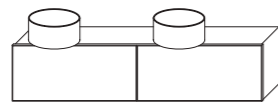

**PIANO DOPPIO 180 SX**  
per 2 ciotole tonde  
for 2 round basins  
PD180CTSX

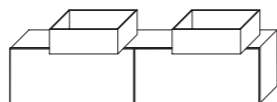

**PIANO DOPPIO 180 DX**  
per 2 ciotole rettangolari  
for 2 rectangular basins  
PD180CRDX

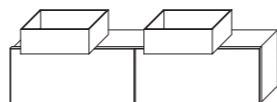

**PIANO DOPPIO 180 SX**  
per 2 ciotole rettangolari  
for 2 rectangular basins  
PD180CRSX

## piano .180 (Muretto)

182x41x 41 cm  
71<sup>5/8</sup>"x16<sup>1/8</sup>"x16<sup>1/8</sup>"

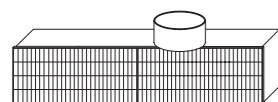

**PIANO DOPPIO 180 DX**  
per 1 ciotola tonda  
for 1 round basin  
PS180CTDXM

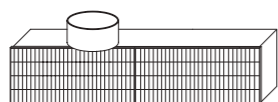

**PIANO DOPPIO 180 SX**  
per 1 ciotola tonda  
for 1 round basin  
PS180CTSXM

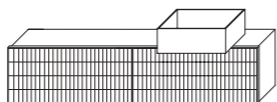

**PIANO DOPPIO 180 DX**  
per 1 ciotola rettangolare  
for 1 rectangular basin  
PS180CRDXM

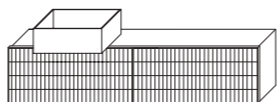

**PIANO DOPPIO 180 SX**  
per 1 ciotola rettangolare  
for 1 rectangular basin  
PS180CRSXM

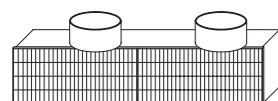

**PIANO DOPPIO 180 DX**  
per 2 ciotole tonde  
for 2 round basins  
PD180CTDXM

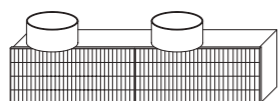

**PIANO DOPPIO 180 SX**  
per 2 ciotole tonde  
for 2 round basins  
PD180CTSXM

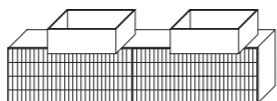

**PIANO DOPPIO 180 DX**  
per 2 ciotole rettangolari  
for 2 rectangular basins  
PD180CRDXM

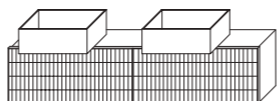

**PIANO DOPPIO 180 SX**  
per 2 ciotole rettangolari  
for 2 rectangular basins  
PD180CRSXM

## piano angle .80

81x48x41 cm  
31<sup>7/8</sup>"x18<sup>7/8</sup>"x16<sup>1/8</sup>"

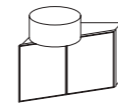

**PIANO ANGOLARE 80 DX**  
per 1 ciotola tonda  
for 1 round basin  
PA80CTDX

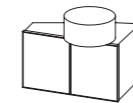

**PIANO ANGOLARE 80 SX**  
per 1 ciotola tonda  
for 1 round basin  
PA80CTSX

## piano angle .80 (Muretto)

81x48x41 cm  
31<sup>7/8</sup>"x18<sup>7/8</sup>"x16<sup>1/8</sup>"

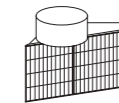

**PIANO ANGOLARE 80 DX**  
per 1 ciotola tonda  
for 1 round basin  
PA80CTDXM

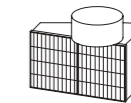

**PIANO ANGOLARE 80 SX**  
per 1 ciotola tonda  
for 1 round basin  
PA80CTSXM

## piano angle .110

114x48x41 cm  
44<sup>7/8</sup>"x18<sup>7/8</sup>"x16<sup>1/8</sup>"

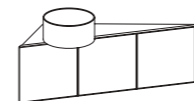

**PIANO ANGOLARE 113 DX**  
per 1 ciotola tonda  
for 1 round basin  
PA113CTDX

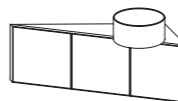

**PIANO ANGOLARE 113 SX**  
per 1 ciotola tonda  
for 1 round basin  
PA113CTSX

## piano angle .110 (Muretto)

114x48x41 cm  
44<sup>7/8</sup>"x18<sup>7/8</sup>"x16<sup>1/8</sup>"

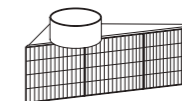

**PIANO ANGOLARE 113 DX**  
per 1 ciotola tonda  
for 1 round basin  
PA113CTDXM

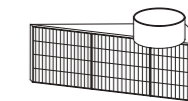

**PIANO ANGOLARE 113 SX**  
per 1 ciotola tonda  
for 1 round basin  
PA113CTSXM

## cilindro (Listello Tratto)

Ø50x87 cm  
Ø19<sup>3/4</sup>"x34<sup>1/4</sup>"



**CILINDRO DIAM 50 ALT 87**  
scarico muro  
wall drainage  
C50TSM



**CILINDRO DIAM 50 ALT 87**  
scarico pavimento  
floor drainage  
C50TSP

## cilindro (Muretto)

Ø50x87 cm  
Ø19<sup>3/4</sup>"x34<sup>1/4</sup>"

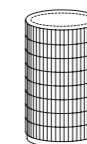

**CILINDRO DIAM 50 ALT 87**  
scarico muro  
wall drainage  
C50MSM

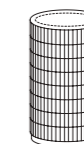

**CILINDRO DIAM 50 ALT 87**  
scarico pavimento  
floor drainage  
C50MSP

Personalizzazione su richiesta in tutti i colori e muretti 6 mm della collezione Mega®. / Customization on request in all 6 mm colors and muretti of the Mega® collection. / Maßanfertigung auf Anfrage in allen Farben und Murretts 6 mm der Kollektionen Mega® erhältlich. / Personnalisation sur demande dans toutes les couleurs et formats mur 6 mm des collections Mega®.

Tutti i modelli sono disponibili anche nella versione Cannettata. / All models are also available in the Cannettata version. / Alle Modelle sind auch in der Version Cannettata erhältlich. / Tous les modèles sont également disponibles dans la version Cannettata.

Codici e misure sono riferite solo al mobile Piano, lavabo escluso. Personalizzazione su richiesta in tutti i colori e muretti 6mm delle collezioni Mega®. / Codes and dimensions refer only to the Piano cabinet, not including the washbasin. Customization on request in all 6 mm colors and muretti of the Mega® collections. / Die Artikelnummern und Maße beziehen sich nur auf den Schrank Piano ohne Waschbecken. Maßanfertigung auf Anfrage in allen Farben und Murretts 6 mm der Kollektionen Mega® erhältlich. / Les codes et mesures se réfèrent uniquement au meuble Piano, sans le lavabo. Personnalisation sur demande dans toutes les couleurs et formats mur 6 mm des collections Mega®.

## piana



### PIANA

101-130 x 50 x 12 cm  
39<sup>3/4"</sup>-51<sup>3/16"</sup> x 19<sup>3/4"</sup> x 4<sup>3/4"</sup>

PNA101130

131-150 x 50 x 12 cm  
51<sup>9/16"</sup>-59<sup>1/8"</sup> x 19<sup>3/4"</sup> x 4<sup>3/4"</sup>

PNA131150

151-160 x 50 x 12 cm  
59<sup>1/2"</sup>-62<sup>7/8"</sup> x 19<sup>3/4"</sup> x 4<sup>3/4"</sup>

PNA151160

161-190 x 50 x 12 cm  
63<sup>3/8"</sup>-74<sup>3/4"</sup> x 19<sup>3/4"</sup> x 4<sup>3/4"</sup>

PNA161190

### TOP MENSOLA PER LAVABO/LAVABI IN APPOGGIO SHELF TOP FOR VESSEL SINKS/WASHBASINS

Lunghezza personalizzabile / Customizable length

Staffe incluse/ Brackets included

Sifone a vista / Exposed siphon

È previsto il rivestimento sui lati a vista del top / The furniture is designed with covering on the visible sides of the piece.

## piana .2



### PIANA .2

151-160 x 50 x 12 cm  
59<sup>1/2"</sup>-62<sup>7/8"</sup> x 19<sup>3/4"</sup> x 4<sup>3/4"</sup>

2PNA151160

161-190 x 50 x 12 cm  
63<sup>3/8"</sup>-74<sup>3/4"</sup> x 19<sup>3/4"</sup> x 4<sup>3/4"</sup>

2PNA161190

191-220 x 50 x 12 cm  
75<sup>1/4"</sup>-86<sup>5/8"</sup> x 19<sup>3/4"</sup> x 4<sup>3/4"</sup>

2PNA191220

### LAVABI / BASIN

Prevista ciotola tonda bianca opaca o bianca lucida / Matt white or glossy white round

Dimensioni ciotola Ø50 x 18 cm / Bowl sizes Ø19<sup>3/4"</sup> x 7<sup>1/8"</sup>

Possibilità di inserire un altro modello di ciotola non presente nella gamma / Possibility to choose another bowl model not available in the collection

Foro troppo pieno non presente / Overflow hole not present

## quadra

50 x 50 x 85 cm  
19<sup>3/4"</sup> x 19<sup>3/4"</sup> x 33<sup>7/16"</sup>

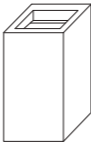

### LAVABO FRESTANDING

scarico muro o a pavimento  
wall drainage or floor drainage

QUADRA5050

## tratto

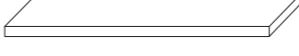

### TRATTO

68-80 x 35 x 5,5 cm  
26<sup>3/4"</sup>-31<sup>1/2"</sup> x 13<sup>3/4"</sup> x 2<sup>3/8"</sup>

TRA6880

81-100 x 35 x 5,5 cm  
31<sup>7/8"</sup>-39<sup>3/8"</sup> x 13<sup>3/4"</sup> x 2<sup>3/8"</sup>

TRA81100

101-130 x 35 x 5,5 cm  
39<sup>3/8"</sup>-51<sup>3/16"</sup> x 13<sup>3/4"</sup> x 2<sup>3/8"</sup>

TRA101130

131-150 x 35 x 5,5 cm  
51<sup>9/16"</sup>-59<sup>1/8"</sup> x 13<sup>3/4"</sup> x 2<sup>3/8"</sup>

TRA131150

151-160 x 35 x 5,5 cm  
59<sup>1/2"</sup>-62<sup>7/8"</sup> x 13<sup>3/4"</sup> x 2<sup>3/8"</sup>

TRA151160

161-190 x 35 x 5,5 cm  
63<sup>3/8"</sup>-74<sup>3/4"</sup> x 13<sup>3/4"</sup> x 2<sup>3/8"</sup>

TRA161190

191-220 x 35 x 5,5 cm  
75<sup>1/4"</sup>-86<sup>5/8"</sup> x 13<sup>3/4"</sup> x 2<sup>3/8"</sup>

TRA191220

221-250 x 35 x 5,5 cm  
87<sup>1/8"</sup>-98<sup>3/8"</sup> x 13<sup>3/4"</sup> x 2<sup>3/8"</sup>

TRA221250

251-270 x 35 x 5,5 cm  
98<sup>7/8"</sup>-106<sup>1/4"</sup> x 13<sup>3/4"</sup> x 2<sup>3/8"</sup>

TRA251270

### MENSOLA PER TOP SCATOLARE E PER TOP MENSOLA SHELF FOR BOX TOP AND FOR SHELF TOP

Lunghezza personalizzabile  
Customizable length

Staffe incluse  
Brackets included

È previsto il rivestimento anche nella parte inferiore della mensola  
The lower part of the shelf is also covered

## linea

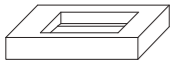

### LINEA

68-80 x 52 x 15 cm  
26<sup>3/4"</sup>-31<sup>1/2"</sup> x 20<sup>1/2"</sup> x 6"

LNA6880

81-100 x 52 x 15 cm  
31<sup>7/8"</sup>-39<sup>3/8"</sup> x 20<sup>1/2"</sup> x 6"

LNA81100

101-130 x 52 x 15 cm  
39<sup>3/8"</sup>-51<sup>3/16"</sup> x 20<sup>1/2"</sup> x 6"

LNA101130

131-150 x 52 x 15 cm  
51<sup>9/16"</sup>-59<sup>1/8"</sup> x 20<sup>1/2"</sup> x 6"

LNA131150

151-160 x 52 x 15 cm  
59<sup>1/2"</sup>-62<sup>7/8"</sup> x 20<sup>1/2"</sup> x 6"

LNA151160

### TOP SCATOLARE CON LAVABO/LAVABI INTEGRATO VANITY TOP WITH INTEGRATED WASH BASIN/BASINS

Lunghezza personalizzabile / Customizable length

Staffe incluse / Brackets included

Scarico a scomparsa / Concealed Drain

## linea .2



### LINEA .2

151-160 x 52 x 15 cm  
59<sup>1/2"</sup>-62<sup>7/8"</sup> x 20<sup>1/2"</sup> x 4<sup>3/4"</sup>

2LNA151160

161-190 x 52 x 15 cm  
63<sup>3/8"</sup>-74<sup>3/4"</sup> x 20<sup>1/2"</sup> x 4<sup>3/4"</sup>

2LNA161190

191-220 x 52 x 15 cm  
75<sup>1/4"</sup>-86<sup>5/8"</sup> x 20<sup>1/2"</sup> x 4<sup>3/4"</sup>

2LNA191220

251-270 x 52 x 15 cm  
98<sup>7/8"</sup>-106<sup>1/4"</sup> x 20<sup>1/2"</sup> x 4<sup>3/4"</sup>

LNA251270

### VASCA / BASIN

Dimensioni vasca 56 x 35 x 10,5 cm / Basin dimension  
22<sup>1/8"</sup> x 13<sup>3/8"</sup> x 4<sup>1/8"</sup>

A richiesta vasca più piccola 49 x 29 x 10,5 cm / Smaller basin on request 19<sup>7/8"</sup> x 11<sup>7/8"</sup> x 4<sup>1/8"</sup>

Il posizionamento della vasca standard è al centro / The positioning of the standard basin is centered

Solo per i lavabi superiori a 131 cm il posizionamento della vasca può essere personalizzato a sinistra, al centro e a destra /

### CANALINA IN ACCIAIO INOX ROTANTE / ROTATING STAINLESS STEEL DRAIN

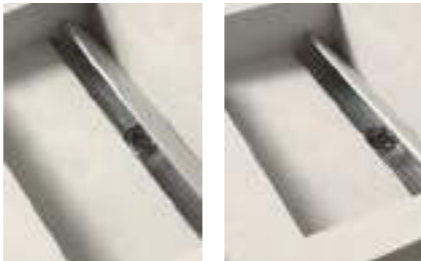

For washbasin longer than 52" only, the basin position can be customized on left, center, or right

La vasca a destra e a sinistra è a 20 cm dal bordo / The basin on the right and left is 7<sup>7/8"</sup> from the edge

Vasca con canalina rotante in acciaio inox removibile per pulizia / Basin with removable rotating stainless-steel drain for cleaning

Foro rubinetto a richiesta / Faucet hole available upon request

Foro troppo pieno non presente / Overflow hole not present

## piatto

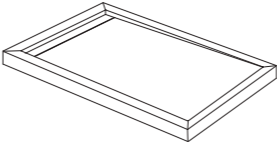

### PIATTO CON CANALINA 70CM SHOWER TRAY WITH A CHANNEL 27<sup>1/2"</sup>

80 x 80-89 cm  
31<sup>1/2"</sup> x 31<sup>1/2"</sup>-35<sup>1/8"</sup>

PT8080-9

80 x 90-99 cm  
31<sup>1/2"</sup> x 35<sup>1/8"</sup>-38<sup>15/16"</sup>

PT8090-9

80 x 100-109 cm  
31<sup>1/2"</sup> x 39<sup>3/8"</sup>-42<sup>15/16"</sup>

PT80100-9

80 x 110-119 cm  
31<sup>1/2"</sup> x 43<sup>5/8"</sup>-46<sup>7/8"</sup>

PT80110-9

80 x 120-129 cm  
31<sup>1/2"</sup> x 47<sup>3/4"</sup>-50<sup>13/16"</sup>

PT80120-9

### PIATTO CON CANALINA 80CM SHOWER TRAY WITH A CHANNEL 31<sup>1/2"</sup>

90 x 90-99 cm  
35<sup>1/8"</sup> x 35<sup>1/8"</sup>-38<sup>15/16"</sup>

PT9090-9

90 x 100-109 cm  
35<sup>1/8"</sup> x 39<sup>3/8"</sup>-42<sup>15/16"</sup>

PT90100-9

90 x 110-119 cm  
35<sup>1/8"</sup> x 43<sup>5/8"</sup>-46<sup>7/8"</sup>

PT90110-9

90 x 120-129 cm  
35<sup>1/8"</sup> x 47<sup>3/4"</sup>-50<sup>13/16"</sup>

PT90120-9

### PIATTO CON CANALINA 90CM SHOWER TRAY WITH A CHANNEL 35<sup>1/8"</sup>

100 x 90-99 cm  
39<sup>3/8"</sup> x 35<sup>1/8"</sup>-38<sup>15/16"</sup>

PT10090-9

100 x 100-109 cm  
39<sup>3/8"</sup> x 39<sup>3/8"</sup>-42<sup>15/16"</sup>

PT100100-9

100 x 110-119 cm  
39<sup>3/8"</sup> x 43<sup>5/8"</sup>-46<sup>7/8"</sup>

PT100110-9

100 x 120-129 cm  
39<sup>3/8"</sup> x 47<sup>3/4"</sup>-50<sup>13/16"</sup>

PT100120-9

### PIATTO DOCCIA CON BORDO E SCARICO LATERALE SHOWER TRAY WITH EDGE AND SIDE DRAIN

Altezza fissa 5 cm  
Fixed height 2"

Dimensione piatto doccia in base alla larghezza della canalina: 70 / 80 / 90 cm  
Shower tray size based on the width of the channel: 27<sup>1/2"</sup> / 31<sup>1/2"</sup> / 35<sup>1/8"</sup>

Scarico e pendenza laterale  
Discharge and lateral slope

Possibilità di posare il piatto doccia a filo pavimento o sopra al pavimento con lati a vista rivestiti  
Possibility of installing the shower tray flush with the floor or above the floor with visible covered sides

## piano lavabi



**LAVELLO CIOTOLA TONDA  
BIANCO OPACO**  
round bowl  
white matt  
CT40BM  
Ø40x18 cm  
15<sup>3/4</sup>"x7<sup>1/8</sup>"



**LAVELLO CIOTOLA TONDA  
BIANCO LUCIDO**  
round bowl  
white gloss  
CT40BG  
Ø40x18 cm  
15<sup>3/4</sup>"x7<sup>1/8</sup>"

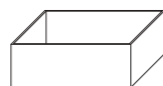

**LAVELLO CIOTOLA RETTANGOLARE  
BIANCO OPACO**  
rectangular bowl  
white matt  
CR50BM  
50x40x18 cm  
19<sup>3/4</sup>"x15<sup>3/4</sup>"x7<sup>1/8</sup>"

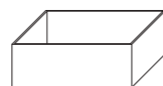

**LAVELLO CIOTOLA RETTANGOLARE  
BIANCO LUCIDO**  
rectangular bowl  
white gloss  
CR50BG  
50x40x18 cm  
19<sup>3/4</sup>"x15<sup>3/4</sup>"x7<sup>1/8</sup>"



**PILETTA CLICK CLACK CROMO  
BIANCO OPACO**  
chrome click clack basin plug  
white matt  
PILBMC



**PILETTA CLICK CLACK CROMO  
BIANCO LUCIDO**  
chrome click clack basin plug  
white gloss  
PILBGC



**PILETTA CLICK CLACK NERO  
BIANCO OPACO**  
black click clack basin plug  
white matt  
PILBMN



**PILETTA CLICK CLACK NERO  
BIANCO LUCIDO**  
black click clack basin plug  
white gloss  
PILBGN

## cilindro lavabi



**CIOTOLA 50  
BIANCO OPACO**  
round bowl  
white matt  
CT50BM  
Ø50x18 cm  
19<sup>3/4</sup>"x7<sup>1/8</sup>"



**CIOTOLA 50  
BIANCO LUCIDO**  
round bowl  
white gloss  
CT50BG  
Ø50x18 cm  
19<sup>3/4</sup>"x7<sup>1/8</sup>"

Lavabi disponibile Bianco Opaco, Bianco Lucido. / Basin available in White Matt, White Gloss.  
Waschbecken erhältlich in Weiß Matt, Weiß Glanz. / Lavabos disponibles Blanc mat, Blanc brillant.

## plico specchio

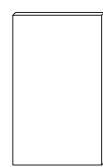

**PLICO 75**  
specchio  
mirror  
PL75  
45x75 cm  
17<sup>3/4</sup>"x29<sup>1/2</sup>"

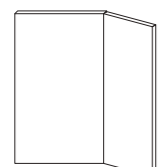

**PLICO ALA 75**  
specchio  
mirror  
PLAL75  
71x75 cm  
28"x29<sup>1/2</sup>"

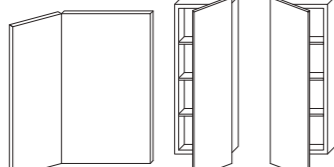

**PLICO BOX 83**  
specchio contenitore  
box mirror  
PLB083  
32x13x83 cm  
12<sup>5/8</sup>"x5<sup>1/8</sup>"x32<sup>5/8</sup>"



**PLICO 110**  
specchio  
mirror  
PL110  
45x110 cm  
17<sup>3/4</sup>"x43<sup>1/4</sup>"

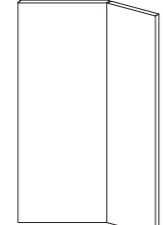

**PLICO ALA 110**  
specchio  
mirror  
PLAL110  
71x110 cm  
28"x43<sup>1/4</sup>"

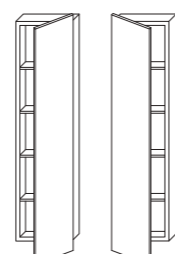
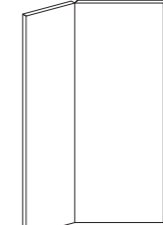

**PLICO BOX 118**  
specchio contenitore  
box mirror  
PLB0118  
32x13x118 cm  
12<sup>5/8</sup>"x5<sup>1/8</sup>"x46<sup>1/2</sup>"

## Listino prezzi / Price list

PIANO.70 mobile contenitore  
storage cabinet

PIANO.90 mobile contenitore  
storage cabinet

PIANO.140 mobile contenitore  
storage cabinet

MODELLO MODEL	DIMENSIONI DIMENSIONS	LAVABO BASIN	CODICE E PREZZO CODE AND PRICE		
			FONDI	MURETTO	CANNETTATO
<b>PIANO. 70</b>					
<b>PIANO. 70 DX</b>	70 x 41 x 41 cm 27 <sup>1/2</sup> " x 16 <sup>1/8</sup> " x 16 <sup>1/8</sup> "	1 ciotola tonda, ordine a parte 1 round basin, ordered separately	P70CTDX 2.100 €	P70CTDXM € 2.300 €	P70CTDXC 2.900 €
<b>PIANO. 70 SX</b>		1 ciotola tonda, ordine a parte 1 round basin, ordered separately	P70CTSX 2.100 €	P70CTSXM € 2.300 €	P70CTSXC 2.900 €
<b>PIANO. 70</b>		1 ciotola rettangolare, ordine a parte 1 rectangular basin ordered separately	P70CRCE 2.100 €	P70CRCEM € 2.300 €	P70CRCEC 2.900 €
<b>PIANO. 90</b>					
<b>PIANO. 90 DX</b>	91 x 41 x 41 cm 35 <sup>7/8</sup> " x 16 <sup>1/8</sup> " x 16 <sup>1/8</sup> "	1 ciotola tonda, ordine a parte 1 round basin, ordered separately	P90CTDX 2.250 €	P90CTDXM 2.500 €	P90CTDXC 2.950 €
<b>PIANO. 90 SX</b>		1 ciotola tonda, ordine a parte 1 round basin, ordered separately	P90CTSX 2.250 €	P90CTSXM 2.500 €	P90CTSXC 2.950 €
<b>PIANO. 90 DX</b>		1 ciotola rettangolare, ordine a parte 1 rectangular basin, ordered separately	P90CRDX 2.250 €	P90CRDXM 2.500 €	P90CRDXC 2.950 €
<b>PIANO. 90 SX</b>		1 ciotola rettangolare, ordine a parte 1 rectangular basin, ordered separately	P90CRSX 2.250 €	P90CRSXM 2.500 €	P90CRSXC 2.950 €
<b>PIANO. 140</b>					
<b>PIANO DOPPIO 140 DX</b>	140 x 41 x 41 cm 55 <sup>1/8</sup> " x 16 <sup>1/8</sup> " x 16 <sup>1/8</sup> "	1 ciotola tonda, ordine a parte 1 round basin, ordered separately	PSI40CTDX 3.600 €	PSI40CTDXM 3.950 €	PSI40CTDXC 4.950 €
<b>PIANO DOPPIO 140 SX</b>		1 ciotola tonda, ordine a parte 1 round basin, ordered separately	PSI40CTSX 3.600 €	PSI40CTSXM 3.950 €	PSI40CTSXC 4.950 €
<b>PIANO DOPPIO 140 DX</b>		1 ciotola rettangolare, ordine a parte 1 rectangular basin, ordered separately	PSI40CRDX 3.600 €	PSI40CRDXM 3.950 €	PSI40CRDXC 4.950 €
<b>PIANO DOPPIO 140 SX</b>		1 ciotola rettangolare, ordine a parte 1 rectangular basin, ordered separately	PSI40CRSX 3.600 €	PSI40CRSXM 3.950 €	PSI40CRSXC 4.950 €
<b>PIANO DOPPIO 140 DX</b>		2 ciotole tonde, ordine a parte 2 round basins, ordered separately	PD140CTDX 3.600 €	PD140CTDXM 3.950 €	PD140CTDXC 4.950 €
<b>PIANO DOPPIO 140 SX</b>		2 ciotole tonde, ordine a parte 2 round basins, ordered separately	PD140CTSX 3.600 €	PD140CTSXM 3.950 €	PD140CTSXC 4.950 €
<b>PIANO DOPPIO 140</b>		2 ciotole rettangolari, ordine a parte 2 rectangular basins, ordered separately	PD140CRCE 3.600 €	PD140CRCEM 3.950 €	PD140CRCEC 4.950 €

## Listino prezzi / Price list

PIANO.180 mobile contenitore  
storage cabinetPIANO ANGLE.80 mobile contenitore  
storage cabinetCILINDRO. 50 lavabo freestanding  
free-standing basinQUADRA lavabo freestanding  
free-standing basinPIANO ANGLE.110 mobile contenitore  
storage cabinetLINEA top scatolare con lavabo integrato  
vanity top with integrated wash basinTRATTO mensola per top scatolare e per top mensola  
shelf for box top and for shelf topPIANA top mensola per lavabo in appoggio  
shelf top for vessel washbasin

MODELLO MODEL	DIMENSIONI DIMENSIONS	LAVABO BASIN	CODICE E PREZZO CODE AND PRICE			
<b>PIANO. 180</b>						
			<b>FONDI</b>	<b>MURETTO</b>	<b>CANNETTATO</b>	
PIANO DOPPIO 180 DX		182 x 41 x 41 cm 7 <sup>5/8</sup> " x 16 <sup>1/8</sup> " x 16 <sup>3/8</sup> "	1 ciotola tonda, ordine a parte 1 round basin, ordered separately	PS180CTDX 3.800 €	PS180CTDXM 4.250 €	PS180CTDXC 5.600 €
PIANO DOPPIO 180 SX			1 ciotola tonda, ordine a parte 1 round basin, ordered separately	PS180CTSX 3.800 €	PS180CTSXM 4.250 €	PS180CTSXC 5.600 €
PIANO DOPPIO 180 DX			1 ciotola rettangolare, ordine a parte 1 rectangular basin, ordered separately	PS180CRDX 3.800 €	PS180CRDXM 4.250 €	PS180CRDXC 5.600 €
PIANO DOPPIO 180 SX			1 ciotola rettangolare, ordine a parte 1 rectangular basin, ordered separately	PS180CRSX 3.800 €	PS180CRSXM 4.250 €	PS180CRSXC 5.600 €
PIANO DOPPIO 180 DX			2 ciotole tonde, ordine a parte 2 round basins, ordered separately	PD180CTDX 3.800 €	PD180CTDXM 4.250 €	PD180CTDXC 5.600 €
PIANO DOPPIO 180 SX			2 ciotole tonde, ordine a parte 2 round basins, ordered separately	PD180CTSX 3.800 €	PD180CTSXM 4.250 €	PD180CTSXC 5.600 €
PIANO DOPPIO 180 DX			2 ciotole rettangolari, ordine a parte 2 rectangular basins, ordered separately	PD180CRDX 3.800 €	PD180CRDXM 4.250 €	PD180CRDXC 5.600 €
PIANO DOPPIO 180 SX			2 ciotole rettangolari, ordine a parte 2 rectangular basins, ordered separately	PD180CRSX 3.800 €	PD180CRSXM 4.250 €	PD180CRSXC 5.600 €
<b>PIANO ANGLE. 80</b>						
			<b>FONDI</b>	<b>MURETTO</b>	<b>CANNETTATO</b>	
PIANO ANGOLARE 80 DX		81 x 48 x 41 cm 3 <sup>1/8</sup> " x 18 <sup>7/8</sup> " x 16 <sup>3/8</sup> "	1 ciotola tonda, ordine a parte 1 round basin, ordered separately	PA80CTDX 2.300 €	PA80CTDXM 2.500 €	PA80CTDXC 3.000 €
PIANO ANGOLARE 80 SX			1 ciotola tonda, ordine a parte 1 round basin, ordered separately	PA80CTSX 2.300 €	PA80CTSXM 2.500 €	PA80CTSXC 3.000 €
<b>PIANO ANGLE. 110</b>						
			<b>FONDI</b>	<b>MURETTO</b>	<b>CANNETTATO</b>	
PIANO ANGOLARE 113 DX		114 x 48 x 41 cm 4 <sup>4/8</sup> " x 18 <sup>7/8</sup> " x 16 <sup>3/8</sup> "	1 ciotola tonda, ordine a parte 1 round basin, ordered separately	PA113CTDX 2.900 €	PA113CTDXM 3.250 €	PA113CTDXC 3.950 €
PIANO ANGOLARE 113 SX			1 ciotola tonda, ordine a parte 1 round basin, ordered separately	PA113CTSX 2.900 €	PA113CTSXM 3.250 €	PA113CTSXC 3.950 €
<b>CILINDRO. 50</b>						
			<b>LISTELLO TRATTO</b>	<b>MURETTO</b>	<b>-</b>	
CILINDRO DIAM 50 ALT 87		Ø 50 x 87 cm Ø 19 <sup>3/4</sup> " x 34 <sup>1/4</sup> "	scarico muro wall drainage	C50TSM 2.500 €	C50MSM 2.500 €	-
CILINDRO DIAM 50 ALT 87			scarico pavimento floor drainage	C50TSP 2.500 €	C50MSP 2.500 €	-
<b>QUADRA</b>						
			<b>FONDI</b>	<b>-</b>	<b>-</b>	
QUADRA LAVABO A TORRE		50 x 50 x 85 cm 9 <sup>3/4</sup> " x 19 <sup>3/4</sup> " x 33 <sup>3/8</sup> "	scarico muro o pavimento wall or floor drainage	QUADRA5050 3.000 €	-	-

MODELLO MODEL	DIMENSIONI DIMENSIONS	CODICE E PREZZO CODE AND PRICE						
<b>PIANI LAVABI / WASHBASIN TOPS</b>								
LINEA *		lavabo wash basin L x 52 x 15 cm L x 20 <sup>1/2</sup> " x 6"	LNA6880 2.800 €	LNA81100 2.800 €	LNA101130 2.900 €	LNA131150 3.100 €	LNA151160 3.300 €	
			L 68-80 cm L 26 <sup>3/4</sup> "-31 <sup>1/2</sup> "	L 81-100 cm L 31 <sup>7/8</sup> "-39 <sup>3/8</sup> "	L 101-130 cm L 39 <sup>3/4</sup> "-x51 <sup>1/8</sup> "	L 131-150 cm L 51 <sup>1/8</sup> "-59 <sup>1/8</sup> "	L 151-160 cm L 59 <sup>1/2</sup> "-62 <sup>7/8</sup> "	
			LNA161190 3.400 €	LNA191220 3.600 €	LNA221250 3.800 €	LNA251270 4.200 €	-	
			L 161-190 cm L 63 <sup>3/8</sup> "-74 <sup>3/4</sup> "	L 191-220 cm L 75 <sup>1/4</sup> "-86 <sup>5/8</sup> "	L 221-250 cm L 87"-98 <sup>3/8</sup> "	L 251-270 cm L 98 <sup>7/8</sup> "-106 <sup>1/4</sup> "	-	
LINEA 2 *		lavabo wash basin L x 52 x 15 cm L x 20 <sup>1/2</sup> " x 6"	-	-	-	-	2LNA151160 € 4.200	
			-	-	-	-	L 151-160 cm L 59 <sup>1/2</sup> "-62 <sup>7/8</sup> "	
			2LNA161190 4.400 €	2LNA191220 4.700 €	2LNA221250 4.900 €	2LNA251270 5.200 €	-	
			L 161-190 cm L 63 <sup>3/8</sup> "-74 <sup>3/4</sup> "	L 191-220 cm L 75 <sup>1/4</sup> "-86 <sup>5/8</sup> "	L 221-250 cm L 87"-98 <sup>3/8</sup> "	L 251-270 cm L 98 <sup>7/8</sup> "-106 <sup>1/4</sup> "	-	
PIANA		lavabo wash basin L x 50 x 12 cm L x 19 <sup>3/4</sup> " x 4 <sup>3/4</sup> "	-	-	PNA101130 1.400 €	PNA131150 1.550 €	PNA151160 1.600 €	
			-	-	-	L 101-130 cm L 39 <sup>3/4</sup> "-x51 <sup>1/8</sup> "	L 131-150 cm L 51 <sup>1/8</sup> "-59 <sup>1/8</sup> "	L 151-160 cm L 59 <sup>1/2</sup> "-62 <sup>7/8</sup> "
			PNA161190 1.800 €	PNA191220 1.900 €	PNA221250 2.100 €	PNA251270 2.200 €	-	
			L 161-190 cm L 63 <sup>3/8</sup> "-74 <sup>3/4</sup> "	L 191-220 cm L 75 <sup>1/4</sup> "-86 <sup>5/8</sup> "	L 221-250 cm L 87"-98 <sup>3/8</sup> "	L 251-270 cm L 98 <sup>7/8</sup> "-106 <sup>1/4</sup> "	-	
PIANA 2		lavabo wash basin L x 50 x 12 cm L x 20 <sup>1/2</sup> " x 4 <sup>3/4</sup> "	-	-	-	-	2PNA151160 1.750 €	
			-	-	-	-	L 151-160 cm L 59 <sup>1/2</sup> "-62 <sup>7/8</sup> "	
			2PNA161190 1.800 €	2PNA191220 1.900 €	2PNA221250 2.100 €	2PNA251270 2.200 €	-	
			L 161-190 cm L 63 <sup>3/8</sup> "-74 <sup>3/4</sup> "	L 191-220 cm L 75 <sup>1/4</sup> "-86 <sup>5/8</sup> "	L 221-250 cm L 87"-98 <sup>3/8</sup> "	L 251-270 cm L 98 <sup>7/8</sup> "-106 <sup>1/4</sup> "	-	
<b>MENSOLE / SHELVES</b>								
TRATTO		mensola shelf L x 35 x 5,5 cm L x 13 <sup>3/4</sup> " x 2 <sup>1/8</sup> "	TRA6880 1.700 €	TRA81100 1.700 €	TRA101130 1.800 €	TRA131150 2.000 €	TRA151160 2.200 €	
			L 68-80 cm L 26 <sup>3/4</sup> "-31 <sup>1/2</sup> "	L 81-100 cm L 31 <sup>7/8</sup> "-39 <sup>3/8</sup> "	L 101-130 cm L 39 <sup>3/4</sup> "-x51 <sup>1/8</sup> "	L 131-150 cm L 51 <sup>1/8</sup> "-59 <sup>1/8</sup> "	L 151-160 cm L 59 <sup>1/2</sup> "-62 <sup>7/8</sup> "	
			TRA161190 2.300 €	TRA191220 2.500 €	TRA221250 2.700 €	TRA251270 2.900 €	-	
			L 161-190 cm L 63 <sup>3/8</sup> "-74 <sup>3/4</sup> "	L 191-220 cm L 75 <sup>1/4</sup> "-86 <sup>5/8</sup> "	L 221-250 cm L 87"-98 <sup>3/8</sup> "	L 251-270 cm L 98 <sup>7/8</sup> "-106 <sup>1/4</sup> "	-	

\* Vasca integrata misura standard 56 x 35 x 10,5 cm, se al momento dell'ordine non viene specificata la vasca a richiesta pu' piccola, verrà fornita la vasca standard / Integrated bath standard size 22<sup>1/8</sup>"x13<sup>3/4</sup>"x4<sup>1/8</sup>".  
If the smaller bath is not specified at the time of ordering, the standard bath will be supplied.\* A richiesta fornitura di vasca più piccola con misure 49 x 29 x 10,5 cm / On request supply of smaller tub with measures 19<sup>1/8</sup>"x 11<sup>7/8</sup>" x 4<sup>1/8</sup>".

\* A richiesta possibilità di ricevere il lavabo con foro per rubinetto centrato al lavabo / On request possibility of receiving the lavabo with a tap hole centered on the sink.

## Listino prezzi / Price list





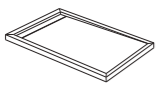
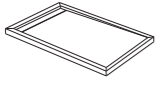
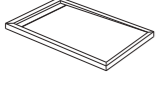
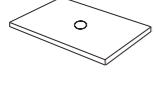





PIATTO piatto doccia con bordo e scarico laterale  
shower tray with edge and side drain

FLUSSO piatto doccia termoformato  
thermoformed shower plate

MODELLO MODEL	DIMENSIONI DIMENSIONS	CODICE E PREZZO CODE AND PRICE															
<b>PIATTI DOCCIA / SHOWER TRAY</b>																	
PIATTO		<table border="1"> <thead> <tr> <th>PT8080-9</th> <th>PT8090-9</th> <th>PT80100-9</th> <th>PT80110-9</th> <th>PT80120-9</th> </tr> </thead> <tbody> <tr> <td>2.500 €</td> <td>2.500 €</td> <td>2.500 €</td> <td>2.500 €</td> <td>2.600 €</td> </tr> <tr> <td>80 x 80-89 cm 31<sup>1/2</sup>" x 31<sup>1/2</sup>"-35<sup>1/8</sup>"</td> <td>80 x 90-99 cm 31<sup>1/2</sup>" x 35<sup>7/16</sup>"-38<sup>1/2</sup>"</td> <td>80 x 100-109 cm 31<sup>1/2</sup>" x 39<sup>3/8</sup>"-42<sup>5/16</sup>"</td> <td>80 x 110-119 cm 31<sup>1/2</sup>" x 43<sup>5/16</sup>"-46<sup>7/8</sup>"</td> <td>80 x 120-129 cm 31<sup>1/2</sup>" x 47<sup>1/4</sup>"-50<sup>3/16</sup>"</td> </tr> </tbody> </table>	PT8080-9	PT8090-9	PT80100-9	PT80110-9	PT80120-9	2.500 €	2.500 €	2.500 €	2.500 €	2.600 €	80 x 80-89 cm 31 <sup>1/2</sup> " x 31 <sup>1/2</sup> "-35 <sup>1/8</sup> "	80 x 90-99 cm 31 <sup>1/2</sup> " x 35 <sup>7/16</sup> "-38 <sup>1/2</sup> "	80 x 100-109 cm 31 <sup>1/2</sup> " x 39 <sup>3/8</sup> "-42 <sup>5/16</sup> "	80 x 110-119 cm 31 <sup>1/2</sup> " x 43 <sup>5/16</sup> "-46 <sup>7/8</sup> "	80 x 120-129 cm 31 <sup>1/2</sup> " x 47 <sup>1/4</sup> "-50 <sup>3/16</sup> "
		PT8080-9	PT8090-9	PT80100-9	PT80110-9	PT80120-9											
2.500 €	2.500 €	2.500 €	2.500 €	2.600 €													
80 x 80-89 cm 31 <sup>1/2</sup> " x 31 <sup>1/2</sup> "-35 <sup>1/8</sup> "	80 x 90-99 cm 31 <sup>1/2</sup> " x 35 <sup>7/16</sup> "-38 <sup>1/2</sup> "	80 x 100-109 cm 31 <sup>1/2</sup> " x 39 <sup>3/8</sup> "-42 <sup>5/16</sup> "	80 x 110-119 cm 31 <sup>1/2</sup> " x 43 <sup>5/16</sup> "-46 <sup>7/8</sup> "	80 x 120-129 cm 31 <sup>1/2</sup> " x 47 <sup>1/4</sup> "-50 <sup>3/16</sup> "													
PIATTO		<table border="1"> <thead> <tr> <th>PT9090-9</th> <th>PT90100-9</th> <th>PT90110-9</th> <th>PT90120-9</th> <th>—</th> </tr> </thead> <tbody> <tr> <td>2.700 €</td> <td>2.700 €</td> <td>2.700 €</td> <td>2.700 €</td> <td>—</td> </tr> <tr> <td>90 x 90-99 cm 35<sup>7/16</sup>" x 35<sup>7/16</sup>"-38<sup>1/2</sup>"</td> <td>90 x 100-109 cm 35<sup>7/16</sup>" x 39<sup>3/8</sup>"-42<sup>5/16</sup>"</td> <td>90 x 110-119 cm 35<sup>7/16</sup>" x 43<sup>5/16</sup>"-46<sup>7/8</sup>"</td> <td>90 x 120-129 cm 35<sup>7/16</sup>" x 47<sup>1/4</sup>"-50<sup>3/16</sup>"</td> <td>—</td> </tr> </tbody> </table>	PT9090-9	PT90100-9	PT90110-9	PT90120-9	—	2.700 €	2.700 €	2.700 €	2.700 €	—	90 x 90-99 cm 35 <sup>7/16</sup> " x 35 <sup>7/16</sup> "-38 <sup>1/2</sup> "	90 x 100-109 cm 35 <sup>7/16</sup> " x 39 <sup>3/8</sup> "-42 <sup>5/16</sup> "	90 x 110-119 cm 35 <sup>7/16</sup> " x 43 <sup>5/16</sup> "-46 <sup>7/8</sup> "	90 x 120-129 cm 35 <sup>7/16</sup> " x 47 <sup>1/4</sup> "-50 <sup>3/16</sup> "	—
		PT9090-9	PT90100-9	PT90110-9	PT90120-9	—											
2.700 €	2.700 €	2.700 €	2.700 €	—													
90 x 90-99 cm 35 <sup>7/16</sup> " x 35 <sup>7/16</sup> "-38 <sup>1/2</sup> "	90 x 100-109 cm 35 <sup>7/16</sup> " x 39 <sup>3/8</sup> "-42 <sup>5/16</sup> "	90 x 110-119 cm 35 <sup>7/16</sup> " x 43 <sup>5/16</sup> "-46 <sup>7/8</sup> "	90 x 120-129 cm 35 <sup>7/16</sup> " x 47 <sup>1/4</sup> "-50 <sup>3/16</sup> "	—													
PIATTO		<table border="1"> <thead> <tr> <th>PT10090-9</th> <th>PT100100-9</th> <th>PT100110-9</th> <th>PT100120-9</th> <th>—</th> </tr> </thead> <tbody> <tr> <td>2.900 €</td> <td>2.900 €</td> <td>2.900 €</td> <td>2.900 €</td> <td>—</td> </tr> <tr> <td>100 x 90-99 cm 39<sup>3/8</sup>" x 35<sup>7/16</sup>"-38<sup>1/2</sup>"</td> <td>100 x 100-109 cm 39<sup>3/8</sup>" x 39<sup>3/8</sup>"-42<sup>5/16</sup>"</td> <td>100 x 110-119 cm 39<sup>3/8</sup>" x 43<sup>5/16</sup>"-46<sup>7/8</sup>"</td> <td>100 x 120-129 cm 39<sup>3/8</sup>" x 47<sup>1/4</sup>"-50<sup>3/16</sup>"</td> <td>—</td> </tr> </tbody> </table>	PT10090-9	PT100100-9	PT100110-9	PT100120-9	—	2.900 €	2.900 €	2.900 €	2.900 €	—	100 x 90-99 cm 39 <sup>3/8</sup> " x 35 <sup>7/16</sup> "-38 <sup>1/2</sup> "	100 x 100-109 cm 39 <sup>3/8</sup> " x 39 <sup>3/8</sup> "-42 <sup>5/16</sup> "	100 x 110-119 cm 39 <sup>3/8</sup> " x 43 <sup>5/16</sup> "-46 <sup>7/8</sup> "	100 x 120-129 cm 39 <sup>3/8</sup> " x 47 <sup>1/4</sup> "-50 <sup>3/16</sup> "	—
		PT10090-9	PT100100-9	PT100110-9	PT100120-9	—											
2.900 €	2.900 €	2.900 €	2.900 €	—													
100 x 90-99 cm 39 <sup>3/8</sup> " x 35 <sup>7/16</sup> "-38 <sup>1/2</sup> "	100 x 100-109 cm 39 <sup>3/8</sup> " x 39 <sup>3/8</sup> "-42 <sup>5/16</sup> "	100 x 110-119 cm 39 <sup>3/8</sup> " x 43 <sup>5/16</sup> "-46 <sup>7/8</sup> "	100 x 120-129 cm 39 <sup>3/8</sup> " x 47 <sup>1/4</sup> "-50 <sup>3/16</sup> "	—													
FLUSSO		<table border="1"> <thead> <tr> <th>FLUS8080</th> <th>FLUS80120</th> <th>FLUS100100</th> <th>FLUS100120</th> <th>—</th> </tr> </thead> <tbody> <tr> <td>2.500 €</td> <td>2.500 €</td> <td>2.700 €</td> <td>2.700 €</td> <td>—</td> </tr> <tr> <td>80 x 80 cm 31<sup>1/2</sup>" x 31<sup>1/2</sup>"</td> <td>80 x 120 cm 31<sup>1/2</sup>" x 47<sup>1/4</sup>"</td> <td>100 x 100 cm 39<sup>3/8</sup>" x 39<sup>3/8</sup>"</td> <td>100 x 120 cm 39<sup>3/8</sup>" x 47<sup>1/4</sup>"</td> <td>—</td> </tr> </tbody> </table>	FLUS8080	FLUS80120	FLUS100100	FLUS100120	—	2.500 €	2.500 €	2.700 €	2.700 €	—	80 x 80 cm 31 <sup>1/2</sup> " x 31 <sup>1/2</sup> "	80 x 120 cm 31 <sup>1/2</sup> " x 47 <sup>1/4</sup> "	100 x 100 cm 39 <sup>3/8</sup> " x 39 <sup>3/8</sup> "	100 x 120 cm 39 <sup>3/8</sup> " x 47 <sup>1/4</sup> "	—
		FLUS8080	FLUS80120	FLUS100100	FLUS100120	—											
2.500 €	2.500 €	2.700 €	2.700 €	—													
80 x 80 cm 31 <sup>1/2</sup> " x 31 <sup>1/2</sup> "	80 x 120 cm 31 <sup>1/2</sup> " x 47 <sup>1/4</sup> "	100 x 100 cm 39 <sup>3/8</sup> " x 39 <sup>3/8</sup> "	100 x 120 cm 39 <sup>3/8</sup> " x 47 <sup>1/4</sup> "	—													



Loom Piatto, I Travertini Bianco Vein Cut

MODELLO MODEL	DIMENSIONI DIMENSIONS	LAVABO BASIN	CODICE E PREZZO CODE AND PRICE	
<b>LAVABI / BASINS</b>			<b>WHITE MATT</b>	
CIOTOLA TONDA		Ø 40 x 18 Ø 15 <sup>3/4</sup> " x 7 <sup>1/8</sup> "	lavello ciotola tonda round bowl	
			CT40BM 650 €	CT40BG 460 €
CIOTOLA RETTANGOLARE		50 x 40 x 18 cm 19 <sup>3/4</sup> " x 15 <sup>3/4</sup> " x 7 <sup>1/8</sup> "	lavello ciotola rettangolare rectangular bowl	
CIOTOLA 50		Ø 50 x 18 Ø 19 <sup>3/4</sup> " x 7 <sup>1/8</sup> "	ciotola 50 round bowl	
<b>ACCESSORI / ACCESSORIES</b>			<b>WHITE MATT</b>	
PILETTA		click clack cromo chrome click clack	PILBMC 110 €	WITH GLOSS PILBGC 90 €
			click clack nero black click clack	PILBMN 135 €
<b>SPECCHI / MIRROR</b>			<b>WHITE GLOSS</b>	
PLICO		45 x 75 cm 17 <sup>3/4</sup> " x 29 <sup>1/2</sup> "	—	PL75 450 €
			—	—
PLICO		71 x 75 cm 28" x 29 <sup>1/2</sup> "	—	PLAL75 1.025 €
			—	—
PLICO		32 x 13 x 83 cm 12 <sup>5/8</sup> " x 5 <sup>1/8</sup> " x 32 <sup>5/8</sup> "	—	PLB083 630 €
			—	—
PLICO		45 x 110 cm 17 <sup>3/4</sup> " x 43 <sup>1/4</sup> "	—	PL110 575 €
			—	—
PLICO		71 x 110 cm 28" x 43 <sup>1/4</sup> "	—	PLAL110 1.225 €
			—	—
PLICO		32 x 13 x 118 cm 12 <sup>5/8</sup> " x 5 <sup>1/8</sup> " x 46 <sup>1/2</sup> "	—	PLB0118 870 €
			—	—

SERVIZI AGGIUNTIVI: se richiesto l'imballo fumigato verrà addebitato il costo di € 200  
ADDITIONAL SERVICES: if fumigated packaging is requested, a cost of 200 € will be charged

**376 Technical Information**

- 378 Certifications
- 388 Special trims 9 mm
- 390 Special trims 20 mm
- 396 Mega: handling, installation, packaging
- 408 Installation advice 9 mm thickness
- 410 Recommended adhesives
- 412 Grouting and cleaning after installation
- 414 Extraordinary cleaning
- 415 Working size chart
- 416 Technical specifications porcelain stoneware
- 418 Symbol captions
- 420 General conditions of sale

## Product and company system certifications



Italgraniti Group è una B Corp. Il Gruppo persegue da tempo strategie che coniugano innovazione e sostenibilità, mirando a incrementare le ricadute positive sulle persone, sul territorio e sull'ambiente agendo in modo responsabile, sostenibile e trasparente. Italgraniti Group prende parte al movimento globale che vede nell'impresa una forza positiva non solo per l'economia ma anche per il benessere delle persone e del pianeta, e che promuove la transizione verso un modello economico inclusivo, equo e rigenerativo.

Die Italgraniti Group ist eine B Corp. Die Gruppe verfolgt seit je her das Ziel, Strategien, die Innovation und Nachhaltigkeit miteinander verbinden, für positive Auswirkungen auf die Menschen, das Gebiet und die Umwelt durch verantwortungsvolles, nachhaltiges und transparentes Handeln zu nutzen. Italgraniti Group nimmt damit an der weltweiten Bewegung teil, die Unternehmen als positive Kraft nicht nur für die Wirtschaft, sondern auch für das Wohlergehen der Menschen und des Planeten sieht und die Förderung des Übergangs zu einem integrativen, fairen und regenerativen Wirtschaftsmodell.

Italgraniti Group ha ottenuto il riconoscimento della Medaglia EcoVadis, una delle più importanti piattaforme internazionali di rating della eco-sostenibilità. EcoVadis mira a migliorare le pratiche ambientali e sociali delle aziende sfruttando l'influenza delle catene logistiche globali. È una delle più importanti piattaforme internazionali di rating dell'eco-sostenibilità e gestisce la prima piattaforma collaborativa che permette alle aziende di monitorare la performance di sostenibilità dei loro fornitori, in 150 settori e in 110 Paesi. Attribuisce un punteggio che consente alla singola azienda una grande visibilità nei confronti di una vasta platea di potenziali clienti, sempre più interessati ai livelli di sostenibilità della supply chain. Il modello di valutazione si basa su standard riconosciuti a livello mondiale come GRI (Global Reporting Initiative), UNGC (Patto Mondiale delle Nazioni unite), ISO 26000 ed è presidiato da un comitato scientifico internazionale: consiste nel verificare, attraverso un questionario, la performance del fornitore in relazione a 4 macro-ambiti:

- Ambiente
- Lavoro e diritti umani
- Etica
- Acquisti sostenibili.

Italgraniti Group wurde mit der EcoVadis-Medaille ausgezeichnet, einer der wichtigsten internationalen Plattformen zur Bewertung der ökologischen Nachhaltigkeit. EcoVadis zielt darauf ab, die Umwelt- und Sozialpraktiken von Unternehmen zu verbessern, in dem der Einfluss globaler Logistikketten genutzt wird. Sie ist eine der führenden internationalen Bewertungsplattformen für ökologische Nachhaltigkeit und betreibt die erste kollaborative Plattform, die es Unternehmen ermöglicht, die Nachhaltigkeitsleistung ihrer Zulieferer in 150 Branchen und 110 Ländern zu überwachen. Es vergibt eine Punktzahl, die dem einzelnen Unternehmen eine hohe Sichtbarkeit bei einem breiten Publikum potenzieller Kunden verleiht, die sich zunehmend für das Nachhaltigkeitsniveau der Lieferkette interessieren. Das Bewertungsmodell basiert auf weltweit anerkannten Standards wie GRI (Global Reporting Initiative), UNGC (United Nations Global Compact), ISO 26000 und wird von einem internationalen wissenschaftlichen Ausschuss überwacht: Es besteht darin, mittels eines Fragebogens die Leistung des Lieferanten in Bezug auf 4 Makroumgebungen zu überprüfen:

- Umwelt
- Arbeit und Menschenrechte
- Ethik
- Nachhaltige Beschaffung.

Italgraniti Group is a B Corp. The Group has long pursued strategies that combine innovation and sustainability, aiming to increase the positive impact on people, the territory and the environment by acting responsibly, sustainably and transparently. Italgraniti Group takes part in the global movement that sees business as a positive force not only for the economy but also for the well-being of people and the planet, and promotes the transition to an inclusive, fair and regenerative economic model.

Le groupe Italgraniti est une B Corp. Le Groupe adopte depuis longtemps des stratégies qui conjuguent innovation et durabilité, dans l'objectif d'augmenter les retombées positives sur les personnes, le territoire et l'environnement, en agissant de manière responsable, durable et transparente. Italgraniti Group a prouvé qu'il a les caractéristiques pour être une B Corp : c'est ainsi qu'il prend part au mouvement global qui voit l'entreprise comme une force positive, non seulement pour l'économie, mais aussi pour le bien-être des personnes et de la planète, et qui stimule la transition vers un modèle économique inclusif, équitable et régénératif.

Italgraniti Group was awarded the EcoVadis Medal, one of the most important international eco-sustainability rating platforms. EcoVadis aims to improve environmental and social practices of companies by harnessing the influence of global logistics chains. It is one of the leading international eco-sustainability rating platforms and operates the first collaborative platform that allows companies to monitor the sustainability performance of their suppliers, in 150 sectors and in 110 countries. It assigns a score that gives the individual company high visibility to a wide audience of potential customers, who are increasingly interested in the sustainability levels of the supply chain.

The evaluation model is based on globally recognised standards such as GRI (Global Reporting Initiative), UNGC (United Nations Global Compact), ISO 26000 and is overseen by an international scientific committee: it consists of verifying, by means of a questionnaire, the supplier's performance in relation to 4 macro-themes:

- Environment
- Labour and human rights
- Ethics
- Sustainable procurement.

Italgraniti Group a obtenu la reconnaissance de la Médaille EcoVadis, une des plus importantes plateformes internationales d'évaluation de la durabilité. EcoVadis vise à améliorer les pratiques environnementales et sociales des entreprises en exploitant l'influence des chaînes d'approvisionnement globales. C'est une des plus importantes plateformes internationales de notation du développement durable. Elle gère la première plateforme collaborative qui permet aux entreprises de contrôler les performances environnementales de leurs fournisseurs, dans 150 secteurs et 110 pays. Elle attribue une note qui donne à chaque entreprise une grande visibilité à l'égard d'un très grand nombre de clients potentiels, toujours plus attentifs aux niveaux d'éco-responsabilité de leur chaînes d'approvisionnement.

Le modèle d'évaluation repose sur des normes reconnues au niveau mondial comme les GRI (Global Reporting Initiative), le Pacte mondial des Nations Unies et la norme ISO 26000. Il est élaboré par un comité scientifique international : son objectif est de vérifier, via un questionnaire, les performances du fournisseur dans 4 secteurs fondamentaux :

- Environnement
- Travail et droits humains
- Éthique
- Approvisionnements durables.



L'EPD (Environmental Product Declaration, dichiarazione ambientale di prodotto) è un documento sintetico che traccia il profilo delle prestazioni ambientali del nostro prodotto e che permette di comunicare informazioni oggettive, confrontabili e credibili al riguardo, senza esprimere criteri di valutazione, preferibilità o livelli minimi da rispettare; permette così, a chi lo consulta, di compiere una scelta consapevole e correttamente informata. Quest'anno ITALGRANITI GROUP ha pubblicato il documento con i dati delle proprie attività su [www.environdec.com](http://www.environdec.com), sito dell'International EPD System, il primo e più longevo programma EPD al mondo.

Die EPD (Environmental Product Declaration - Umweltproduktdeklaration) ist ein kurzes Dokument, das das Umweltleistungsprofil unseres Produkts beschreibt und es uns ermöglicht, objektive, vergleichbare und glaubwürdige Informationen in dieser Hinsicht zu übermitteln, ohne Bewertungskriterien, Vorzugswerte oder einzuhalten Mindestwerte zu nennen; es ermöglicht denjenigen, die es konsultieren, eine bewusste und korrekt informierte Wahl zu treffen. In diesem Jahr hat die ITALGRANITI GROUP ihre Aktivitätsdaten auf [www.environdec.com](http://www.environdec.com) veröffentlicht, der Website des International EPD System, dem weltweit ersten und am längsten bestehenden EPD-Programm.

The EPD (Environmental Product Declaration) is a concise document that outlines the environmental performance profile of our product and allows us to communicate objective, comparable and credible information in this regard, without expressing evaluation, preferability or minimum levels to be respected; it thus allows those who read it to make a conscious and correctly informed choice. This year ITALGRANITI GROUP published its activity data on [www.environdec.com](http://www.environdec.com), the website of the International EPD System, the world's first and longest running EPD program.

L'EPD (Environmental Product Declaration, déclaration environnementale de produit) est un document synthétique qui présente le profil des performances environnementales de notre produit et qui permet de communiquer des informations objectives, comparables et crédibles à cet égard, sans exprimer de critères d'évaluation, de préférences ou des paramètres minimums à respecter ; sa consultation permet de faire un choix conscient et informé. Cette année, ITALGRANITI GROUP a publié le document avec les données de ses activités sur [www.environdec.com](http://www.environdec.com), le site de l'International EPD System, le principal et le plus ancien programme EPD au monde.



### ISO 14064-1



La certificazione ISO 14064-1 permette alle organizzazioni di quantificare le proprie emissioni di GHG al fine di attuare delle politiche di Carbon Management e comunicare il proprio impegno in tema di sostenibilità ai propri stakeholder. Italgraniti Group ha intrapreso un percorso di rendicontazione delle proprie emissioni e rimozioni di gas ad effetto serra (GHGs). Lo studio intende rispondere ad una esigenza orientata, non solo alla conoscenza della propria Impronta di Carbonio ma anche all'individuazione di possibili strategie e azioni volte a ridurre le emissioni di GHG. Questa importante certificazione testimonia l'approccio pro-attivo del Gruppo e la capacità di fornire dati coerenti ed affidabili sulla propria Carbon Footprint.

Die ISO 14064-1-Zertifizierung ermöglicht es Organisationen, ihre Treibhausgasemissionen zu quantifizieren, um Strategien für das Kohlenstoffmanagement umzusetzen und ihren Stakeholdern ihr Engagement für Nachhaltigkeit zu vermitteln. Italgraniti Group hat begonnen ihre Treibhausgasemissionen zu messen und über deren Abbau zu berichten. Mit der Studie soll einem Bedürfnis entsprochen werden, das nicht nur darauf abzielt, den eigenen Carbon Footprint zu kennen, sondern auch darauf, mögliche Strategien und Maßnahmen zur Reduzierung von Treibhausgasemissionen zu ermitteln. Diese wichtige Zertifizierung bestätigt den proaktiven Ansatz der Gruppe und ihre Fähigkeit, konsistente und zuverlässige Daten über ihren Carbon Footprint zu liefern.

ISO 14064-1 certification allows organisations to quantify their GHG emissions to implement carbon management policies and communicate their sustainability commitment to their stakeholders. Italgraniti Group started a reporting path on their greenhouse gases (GHG) emissions and removal. The study intends to respond to a need geared not only towards knowing their own Carbon Footprint but also towards identifying possible strategies and actions aimed at reducing GHG emissions. This important certification proves the Group proactive approach and the ability to provide consistent and reliable data on their Carbon Footprint.

La certification ISO 14064-1 permet aux organisations de quantifier leurs émissions de gaz à effet de serre afin de mettre en place des politiques de gestion du bilan carbone et de communiquer à leurs parties prenantes leur engagement en matière de durabilité. Italgraniti Group s'est engagé dans une démarche visant à rendre compte de ses émissions et suppressions de gaz à effet de serre. L'étude entend répondre à un besoin visant non seulement à connaître sa propre empreinte carbone mais aussi à identifier les stratégies et actions possibles pour réduire les émissions de gaz à effet de serre. Cette importante certification témoigne de l'approche proactive du Groupe et de sa capacité à fournir des données cohérentes et fiables sur son empreinte carbone.



Website

# Product and company system certifications

## ISO 14001 EMAS



Italgraniti Group opera in conformità alle normative ambientali previste dalla certificazione ISO 14001 e del regolamento EMAS, ottenuta da oltre 10 anni. La certificazione europea EMAS (Eco-Management and Audit Scheme) misura e controlla il ridotto impatto sull'ambiente dei siti produttivi, attraverso un sistema di gestione ambientale basato su rigorosi parametri.

### ITALGRANITI GROUP CONTRIBUISCE ALL'EFFICIENZA ENERGETICA ATTRAVERSO:

- 100% di riciclaggio delle acque utilizzate
- 100% riciclo degli scarti crudi e cotti
- 100% riciclo del packaging e dei pallet

Umweltmanagement: Umweltzertifikat EMAS-ISO 14001  
Italgraniti Group arbeitet in Übereinstimmung mit den Umweltvorschriften, die durch die vor mehr als 10 Jahren erlangte Zertifizierung nach ISO 14001 und der EMAS-Verordnung vorgesehen sind. Die europäische EMAS-Zertifizierung (Eco-Management and Audit Scheme) misst und kontrolliert die reduzierten Umweltauswirkungen von Produktionsstätten durch ein Umweltmanagementsystem, das auf strengen Parametern basiert.

### DIE ITALGRANITI GROUP TRÄGT ZUR ENERGIEEFFIZIENZ BEI DURCH:

- 100 % Recycling von Wasser aus der Verarbeitung
- 100 % Recycling von rohem und gebranntem Ausschussmaterial
- 100 % Recycling von Verpackungen und Paletten

Italgraniti Group conforms with the environmental regulations envisaged by the ISO 14001 certification and by the EMAS certification, obtained more than 10 years ago. The European EMAS (Eco-Management and Audit Scheme) certification measures and controls the reduced environmental impact of production sites, through an environmental management system based on strict parameters.

### ITALGRANITI GROUP CONTRIBUTES TOWARDS ENERGY EFFICIENCY THROUGH:

- 100% recycling of waters used
- 100% recycling of unfired and fired waste
- 100% recycling of packaging and pallets

Système de management environnemental (s.m.e.): certification EMAS-ISO 14001

Italgraniti Group opère en conformité avec les réglementations environnementales prévues par la certification ISO 14001, obtenue depuis plus de 10 ans, et le règlement EMAS. La certification européenne EMAS (Eco-Management and Audit Scheme) mesure et contrôle l'impact réduit sur l'environnement des sites de production via un système de management environnemental basé sur des paramètres stricts.

### ITALGRANITI GROUP CONTRIBUE À L'EFFICACITÉ ÉNERGÉTIQUE VIA :

- recyclage de 100 % des eaux utilisées
- recyclage de 100 % des déchets crus et cuits
- recyclage de 100 % des emballages et des palettes



## UNI/PDR 125:2022



Italgraniti Group è la prima azienda ceramica in Italia ad aver ottenuto la Certificazione di Genere secondo lo standard UNI/PDR 125:2022. La parità di genere è un elemento fondamentale per combattere le discriminazioni nel mondo del lavoro e per realizzare i propri obiettivi strategici. Il rispetto della persona, congiuntamente con il suo sviluppo professionale, sono considerati valori imprescindibili per il Gruppo, il quale reputa le capacità relazionali, intellettive, organizzative e tecniche di ogni dipendente una risorsa fondamentale per l'organizzazione.

Italgraniti is the first ceramic company in Italy to have obtained the Gender Equality Certification according to the UNI/PDR 125:2022 standard. Gender equality is a key element in fighting discriminations in the workplace and in achieving strategic goals. Respect for the people, along with their professional growth, are considered unavoidable values by the Group, which considers employees' relational, intellectual, organizational, technical capabilities as an essential resource for the company.

Die Italgraniti Group ist das erste Keramikunternehmen in Italien, das die Zertifizierung der Gleichstellung der Geschlechter nach der Norm UNI/PDR 125:2022 erhalten hat. Die Gleichstellung der Geschlechter ist ein Schlüsselement bei der Bekämpfung von Diskriminierung in der Arbeitswelt und bei der Verwirklichung ihrer strategischen Ziele. Der Respekt vor dem Einzelnen und seine berufliche Entwicklung sind für die Gruppe von grundlegender Bedeutung. Die Gruppe betrachtet die zwischenmenschlichen, intellektuellen, organisatorischen und technischen Fähigkeiten eines jeden Mitarbeiters als grundlegende Ressource für das Unternehmen.

Italgraniti Group est la première entreprise céramique italienne à avoir obtenu la Certification pour l'égalité des sexes en vertu de la norme UNI/PDR 125:2022. L'égalité hommes-femmes est un élément fondamental pour lutter contre les discriminations dans le monde du travail et atteindre nos objectifs stratégiques. Le respect de la personne et son développement professionnel sont des valeurs essentielles pour le Groupe qui considère les capacités relationnelles, intellectuelles, organisationnelles et techniques de chaque employé comme une ressource fondamentale pour l'entreprise.

## ISO 9001



La certificazione UNI ISO 9001 2015 è riconosciuta a livello internazionale e rappresenta una garanzia di eccellenza e qualità del proprio sistema di gestione. ITALGRANITI GROUP ha deciso di intraprendere spontaneamente questo importante percorso adottando un insieme di regole, responsabilità e controlli per migliorare l'efficienza dei processi e la soddisfazione del cliente, accrescere la propria competitività e mantenere la conformità ai più alti standard qualitativi.

UNI ISO 9001 2015 certification is internationally recognised and represents a guarantee of the excellence and quality of the management system. ITALGRANITI GROUP decided of its own accord to undertake this important process, adopting a set of rules, responsibilities and checks to improve the efficiency of processes and customer satisfaction, to boost its competitiveness and maintain compliance with the highest quality standards.

Die Zertifizierung nach UNI ISO 9001 2015 ist international anerkannt und stellt eine Garantie für die Exzellenz und Qualität des Managementsystems dar. Die ITALGRANITI GROUP hat beschlossen, diesen wichtigen Weg spontan zu gehen, indem sie eine Reihe von Regeln, Verantwortlichkeiten und Kontrollen annimmt, um die Effizienz der Prozesse und die Kundenzufriedenheit zu verbessern, ihre Wettbewerbsfähigkeit zu erhöhen und die Einhaltung der höchsten Qualitätsstandards zu gewährleisten.

La certification UNI ISO 9001 2015 est reconnue au niveau international et représente une garantie d'excellence et de qualité du système de gestion. ITALGRANITI GROUP a décidé d'entreprendre spontanément cet important parcours en adoptant un ensemble de règles, responsabilités et contrôles pour améliorer l'efficacité des processus et la satisfaction du client, accroître sa compétitivité et rester conforme aux standards de qualité les plus élevés.



Website

## Product and company system certifications

### ISO 45001



La salute e il benessere dei lavoratori sono interessi primari per ITALGRANITI GROUP. L'ottenimento della certificazione UNI ISO 45001 rafforza una cultura d'impresa che vede la sicurezza non solo come a un adempimento normativo, ma come parte essenziale dei processi lavorativi. La normativa è uno strumento necessario per generare un nuovo modello di competitività sostenibile che possa migliorare la crescita di tutte le performance aziendali.

Die Gesundheit und das Wohlbefinden der Mitarbeiter sind für die ITALGRANITI GROUP von größter Bedeutung. Die Zertifizierung nach UNI ISO 45001 stärkt eine Unternehmenskultur, die Sicherheit nicht nur als regulatorische Anforderung, sondern als wesentlichen Bestandteil von Arbeitsprozessen versteht. Das Normenwerk ist ein notwendiges Instrument, um ein neues Modell der nachhaltigen Wettbewerbsfähigkeit zu schaffen, das das Wachstum der gesamten Unternehmensleistung verbessern kann.

The health and wellbeing of employees are crucial priorities for ITALGRANITI GROUP. The attainment of UNI ISO 45001 certification strengthens a business culture that sees safety not simply as a question of regulatory compliance, but as an essential part of working processes. Regulation is a necessary tool for generating a new model of sustainable competitiveness that can improve company performance across the board.

La santé et le bien-être des travailleurs sont au cœur des préoccupations chez ITALGRANITI GROUP. L'obtention de la certification UNI ISO 45001 renforce une culture d'entreprise qui considère la sécurité non pas seulement comme une norme à respecter, mais comme une facette essentielle des processus de production. Les normes représentent un outil nécessaire pour créer un nouveau modèle de compétitivité durable en mesure d'améliorer la croissance de toutes les performances d'entreprise.



Italgraniti Group ha adottato lo standard collaborativo HPD Dichiarazioni di Salubrità di Prodotto (Health Product Declarations), per comunicare in modo trasparente il contenuto dei propri materiali e il relativo impatto sulla salute. Grazie all'HPD, i nostri prodotti contribuiscono all'ottenimento di crediti LEED® e WELL™.

Die Italgraniti Group hat den kollaborativen HPD-Standard (Health Product Declarations) übernommen, um die Zusammensetzung der Materialien und deren Auswirkungen auf die Gesundheit transparent zu kommunizieren. Dank HPD tragen unsere Produkte zu LEED® - und WELL™-Punkten bei.

Italgraniti Group has adopted the HPD (Health Product Declarations) collaborative standard to communicate the contents of its materials and the related impact on health in a transparent manner. Thanks to HPD, our products contribute towards obtaining LEED® and WELL™ credits.

Italgraniti Group a adopté la norme collaborative DEP - Déclarations environnementales et sanitaires de produit, afin de communiquer de manière transparente le contenu de ses matériaux et leur impact sur la santé. Grâce à la DEP, nos produits contribuent à l'obtention de crédits LEED® et WELL™.

### LEED COMPLIANT

I prodotti di ITALGRANITI GROUP rispondono ai requisiti richiesti dalle certificazioni LEED. I crediti LEED forniscono a tutte le parti interessate gli strumenti necessari per calcolare in modo oggettivo l'impatto di uno stabile in termini di sostenibilità ambientale. Il sistema si basa sull'attribuzione, per ciascuno dei requisiti caratterizzanti l'eco-compatibilità di un edificio, di crediti che, sommati tra loro, danno il livello di certificazione ottenuto: più alto è, più cresce il valore competitivo dell'immobile sul mercato. I nostri prodotti non rilasciano sostanze tossiche e non contribuiscono all'effetto isola di calore; inoltre, escono da uno stabilimento dotato di sistema di gestione ambientale certificato. Per realizzarli viene utilizzata una percentuale certificata di materiale riciclato superiore al 20% (materiale pre-consumo). Questa certificazione è stata rilasciata da Bureau Veritas Italia S.p.A.

Die Produkte der ITALGRANITI GROUP erfüllen die Anforderungen der LEED-Zertifizierung. Die LEED-Credits geben allen interessierten Parteien die notwendigen Instrumente an die Hand, um die Auswirkungen eines Gebäudes im Hinblick auf die ökologische Nachhaltigkeit objektiv zu berechnen. Das System beruht darauf, dass für jede der Anforderungen, die die Umweltverträglichkeit eines Gebäudes kennzeichnen, Punkte vergeben werden, die in ihrer Summe das erreichte Zertifizierungsniveau ergeben: Je höher dieses ist, desto größer ist der Wettbewerbswert des Gebäudes auf dem Markt. Unsere Produkte setzen keine giftigen Stoffe frei, tragen nicht zum Wärmeinseleffekt bei und verlassen ein Werk mit einem zertifizierten Umweltmanagementsystem. Für ihre Herstellung wird ein zertifizierter Anteil von mehr als 20 Prozent recyceltem Material (Pre-Consumer-Material) verwendet. Diese Zertifizierung wurde von Bureau Veritas Italia S.p.A. ausgestellt.

ITALGRANITI GROUP's products meet the requirements of LEED certifications. LEED credits provide all interested parties with the necessary tools to objectively calculate the impact of a building in terms of environmental sustainability. The system is based on the attribution - for each of the requirements characterising the eco-compatibility of a building - of credits that, added together, give the level of certification obtained: the higher it is, the greater the competitive value of the building on the market. Our products do not release toxic substances and do not contribute to the heat island effect; moreover, they come from a plant with a certified environmental management system. A certified percentage of more than 20% recycled material (pre-consumer material) is used to manufacture them. This certification was issued by Bureau Veritas Italia S.p.A.

Les produits ITALGRANITI GROUP respectent les exigences stipulées par les certifications LEED. Les crédits LEED fournissent les outils nécessaires pour calculer objectivement l'impact de durabilité environnementale d'un bâtiment. Le système se base sur l'attribution, pour chacune des exigences d'eco-compatibilité d'un bâtiment, de crédits qui, cumulés, donnent le niveau de certification atteint : plus il est élevé, plus sa valeur concurrentielle augmente. Nos produits ne cèdent pas de substances toxiques et ne contribuent pas à l'effet 'îlot de chaleur' ; ils sont fabriqués dans une usine avec un système de management environnemental certifié. Un pourcentage certifié de matières recyclées supérieur à 20 % (matériau pré-consommation) est utilisé pour leur réalisation. Cette certification a été délivrée par Bureau Veritas Italia.



Italgraniti Group è membro del Green Building Council Italia, organizzazione che promuove la cultura e la pratica dell'edilizia sostenibile in un contesto che rispetti le esigenze dell'uomo, della collettività e dell'ambiente.

Italgraniti Group is a member of the Green Building Council Italia, an organisation that promotes the culture and practice of sustainable construction in a context that respects the needs of mankind, the collective whole and the environment.

Die Italgraniti Group ist Mitglied des Green Building Council Italia, einer Organisation, die die Kultur und Praxis des nachhaltigen Bauens in einem Kontext fördert, der die Bedürfnisse der Menschen, der Gemeinschaft und der Umwelt respektiert.

Italgraniti Group est membre du Green Building Council Italia, organisation qui promeut la culture et la pratique d'une construction durable dans le respect des exigences de l'homme, de la collectivité et de l'environnement.



Website

## Product and company system certifications



Il GreenGuard è una Certificazione di Prodotto Ambientale che attesta l'emissione di bassi livelli di sostanze chimiche, come ftalati, benzene, ammine e formaldeide. Ha particolare importanza per quelle aziende che, come ITALGRANITI GROUP, partecipano a forniture contract legate a protocolli di green building, come il LEED statunitense. Questi sistemi di rating attribuiscono all'edificio un punteggio basato sui materiali che esso impiega. Insieme ad altre certificazioni, GreenGuard assegna al prodotto impiegato un credito che concorre a definire il punteggio dell'edificio. Nata negli USA per volontà di un organismo senza fini di lucro, GreenGuard prevede che i prodotti siano sottoposti a test scientifici indipendenti e a un monitoraggio continuo delle emissioni chimiche. Ottengono la certificazione quei prodotti che ne soddisfano gli standard rigorosi, basati su criteri stabiliti da importanti agenzie di salute pubblica.

GreenGuard ist eine Umweltzertifizierung für Produkte, die nur geringe Mengen an Chemikalien wie Phthalate, Benzol, Amine und Formaldehyd enthalten. Sie ist besonders für Unternehmen sehr wichtig, die wie die ITALGRANITI GROUP an Ausschreibungen teilnehmen, die mit Protokollen für grünes Bauen, wie dem amerikanischen LEED, verbunden sind. Diese Systeme bewerten die Gebäude aufgrund der verwendeten Materialien. Zusammen mit anderen Zertifizierungen ermöglicht GreenGuard eine bessere Bewertung des Gebäudes. GreenGuard entstand in den USA über eine gemeinnützigen Organisation und verlangt, dass Produkte unabhängigen wissenschaftlichen Tests und einer kontinuierlichen Überwachung der chemischen Emissionen unterzogen werden. Zertifiziert werden Produkte, die die strengen Anforderungen erfüllen, die auf den Kriterien der führenden Gesundheitsbehörden basieren.

The GreenGuard is an Environmental Product Certification that certifies the emission of low levels of chemicals, such as phthalates, benzene, amines and formaldehyde. It has particular importance for those companies that, like ITALGRANITI GROUP, participate in contract supplies linked to green building protocols, such as the US LEED. These rating systems give the building a score based on the materials it uses. Together with other certifications, GreenGuard assigns the product used a credit that contributes to the building's score. Created in the US by a non-profit organisation, GreenGuard requires products to undergo independent scientific testing and continuous monitoring of chemical emissions. Those products that meet strict standards, based on criteria set by leading public health agencies, are certified.

La certification GreenGuard est une certification environnementale qui atteste qu'un produit émet de faibles niveaux de substances chimiques comme les phthalates, les benzènes, les amines et les formaldéhydes. Elle revêt une importance particulière pour les entreprises qui, comme ITALGRANITI GROUP, participent à des projets immobiliers en application de protocoles de construction écologique, comme la certification LEED américaine. Ces systèmes de notation attribuent des points au bâtiment en fonction des matériaux utilisés pour sa construction. Associée à d'autres certifications, GreenGuard attribue des crédits au produit utilisé qui permettent de définir les points accordés au bâtiment. Née aux Etats-Unis de la volonté d'un organisme sans but lucratif, GreenGuard prévoit que les produits soient soumis à des essais scientifiques indépendants et à une surveillance constante des émissions chimiques. La certification est accordée aux produits qui respectent ses normes strictes, basées sur des critères établis par des agences de santé publique reconnues.

BREEAM® (Building Research Establishment Environmental Assessment Method), which was developed in 1990 by BRE Global, is one of the main systems in the world used to measure the environmental and sustainability performance of new and existing buildings. The BREEAM® assessment uses a range of indicators and sustainability criteria to assess the performance levels of a building, covering several environmental topics: energy and water resources, health and wellbeing, pollution, transport, materials, waste, environmental awareness and management processes. All Italgraniti collections contribute towards obtaining BREEAM® credits.

Le BREEAM® (Building Research Establishment Environmental Assessment Method), développé en 1990 par le BRE Global, est un des principaux systèmes utilisés dans le monde pour mesurer les performances environnementales et de durabilité des bâtiments neufs et existants. L'évaluation BREEAM® utilise une gamme d'indicateurs et de critères de durabilité pour estimer les performances du bâtiment en couvrant plusieurs thématiques environnementales : énergie et ressources hydriques, santé et bien-être, pollution, transports, matériaux, déchets, écologie et processus de gestion. Toutes les collections Italgraniti contribuent à obtenir des crédits BREEAM®.

BREEAM® (Building Research Establishment Environmental Assessment Method), sviluppato nel 1990 dal BRE Global, è uno dei principali sistemi al mondo utilizzato per misurare le prestazioni ambientali e di sostenibilità degli edifici nuovi ed esistenti. La valutazione BREEAM® utilizza una gamma di indicatori e criteri di sostenibilità per valutare le prestazioni dell'edificio coprendo diverse tematiche ambientali: energy e risorse idriche, salute e benessere, inquinamento, trasporti, materiali, rifiuti, ecologia e processi di gestione. Tutte le collezioni Italgraniti contribuiscono al raggiungimento dei crediti BREEAM®.

BREEAM® (Building Research Establishment Environmental Assessment Method), 1990 von BRE Global entwickelt, ist eines der weltweit führenden Systeme zur Messung der Umwelt- und Nachhaltigkeitsleistung von neuen und bestehenden Gebäuden. Die BREEAM®-Bewertung verwendet eine Reihe von Nachhaltigkeitsindikatoren und -kriterien, um die Leistung von Gebäuden zu bewerten, die verschiedene Umweltaspekte abdecken: Energie- und Wasserressourcen, Gesundheit und Wohlbefinden, Umweltverschmutzung, Transport, Materialien, Abfall, Ökologie und Managementprozesse. Alle Italgraniti-Kollektionen tragen zum Erreichen der BREEAM®-Punkte bei.

## WELL™

WELL™ Building Standard (WELL™) è il primo sistema di rating per l'edilizia sostenibile che consente di misurare, certificare e monitorare le caratteristiche dell'edificio che hanno un impatto sulla salute e sul benessere degli occupanti. Il WELL™ fornisce un percorso per integrare e misurare i temi della salute umana e del benessere nella progettazione, costruzione e gestione di edifici. Per ottenere la certificazione WELL™ Building Standard™, l'edificio deve essere sottoposto a un processo che comprende una valutazione in loco e una verifica delle prestazioni da parte di un certificatore abilitato. Tutte le collezioni Italgraniti contribuiscono al raggiungimento dei crediti WELL™.

WELL™ Building Standard (WELL™) ist das erste Bewertungssystem für nachhaltige Gebäude zur Messung, Zertifizierung und Überwachung von Gebäudeeigenschaften, die sich auf die Gesundheit und das Wohlbefinden der Bewohner auswirken. WELL™ bietet einen Weg zur Integration und Messung von Aspekten der menschlichen Gesundheit und des Wohlbefindens bei der Planung, dem Bau und dem Betrieb von Gebäuden. Um die WELL™ Building Standard™-Zertifizierung zu erhalten, muss das Gebäude einen Prozess durchlaufen, der eine Vor-Ort-Beurteilung und eine Leistungsüberprüfung durch einen zugelassenen Zertifizierer umfasst. Alle Italgraniti-Kollektionen tragen zum Erreichen der WELL™-Punkte bei.

I Criteri Ambientali Minimi (CAM) sono i requisiti ambientali ed ecologici definiti dal Ministero dell'Ambiente. Con decreto 23 giugno 2022 il Ministero della Transizione Ecologica ha disposto la loro revisione (Criteri ambientali minimi per l'affidamento del servizio di progettazione ed esecuzione dei lavori di interventi edilizi). I CAM mirano a facilitare l'inserimento di requisiti di eco-sostenibilità nelle gare d'appalto per interventi pubblici. L'obiettivo è quello di stimolare acquisti che minimizzino l'uso di risorse naturali e il consumo di energia, che contribuiscano inoltre alla diffusione di fonti rinnovabili, riducano la produzione di rifiuti, le emissioni inquinanti nell'aria, nell'acqua e nel suolo ed che eliminino le sostanze ambientalmente pericolose. Grazie ad un sistema di gestione ambientale sostenibile, alla certificazione EPD e in accordo con lo standard internazionale ISO 14021, Italgraniti contribuisce ad un'edilizia di qualità e prestazioni al di sopra della media di settore.

Die Mindestumweltkriterien (CAM) sind die vom Umweltministerium festgelegten Umwelt- und ökologischen Anforderungen. Mit Erlass vom 23. Juni 2022 ordnete das Ministerium für den ökologischen Wandel deren Überarbeitung an (Mindestumweltkriterien für die Vergabe von Planungs- und Ausführungsleistungen für Bauarbeiten). CAM zielt darauf ab, die Aufnahme von Anforderungen an die ökologische Nachhaltigkeit in Ausschreibungen für öffentliche Interventionen zu erleichtern. Ziel ist es, Einkäufe anzuregen, die den Verbrauch natürlicher Ressourcen und den Energieverbrauch minimieren, die auch zur Verbreitung erneuerbarer Quellen beitragen, die Abfallproduktion und Schadstoffemissionen in Luft, Wasser und Boden reduzieren und umweltgefährdende Stoffe abschaffen. Dank eines nachhaltigen Umweltmanagementsystems, der EPD-Zertifizierung und in Übereinstimmung mit der internationalen Norm ISO 14021 trägt Italgraniti zu einer über dem Branchendurchschnitt liegenden Bauqualität und -leistung bei.

Ongreening.com fornisce informazioni dettagliate sulla conformità e il contributo dei prodotti Italgraniti Group ai principali sistemi di certificazione della sostenibilità degli edifici (LEED®, BREEAM®, WELL™, CAM ed altri).

Ongreening.com bietet detaillierte Informationen über die Konformität und den Beitrag der Produkte der Italgraniti Group zu den wichtigsten Nachhaltigkeitszertifizierungssystemen für Gebäude (LEED®, BREEAM®, WELL™, CAM und andere) bei.

WELL™ Building Standard (WELL™) is the number one rating system for sustainable construction designed to measure, certify and monitor the features of the building, which have an impact on the health and wellbeing of its occupants. WELL™ provides a path to integrate and measure topics of human health and wellbeing in the design, construction and management of buildings. To obtain the WELL™ Building Standard™ certification, the building must undergo a process which includes an on-site assessment and an inspection of performance levels by a qualified certifier. All Italgraniti collections contribute towards obtaining WELL™ credits.

Le WELL™ Building Standard (WELL™) est le premier système d'évaluation pour le bâtiment durable qui permet de mesurer, certifier et surveiller les caractéristiques du bâtiment qui ont un impact sur la santé et le bien-être des occupants. Le WELL™ fournit un parcours pour intégrer et mesurer les thèmes de la santé humaine et du bien-être dans la conception, la construction et la gestion des bâtiments. Pour obtenir la certification WELL™ Building Standard™, le bâtiment doit être soumis à un processus qui inclut une évaluation sur site et une vérification des performances par un certificateur agréé. Toutes les collections Italgraniti contribuent à obtenir des crédits WELL™.

The Minimum Environmental Criteria (CAM) are the environmental and ecological requirements defined by the Italian Ministry of the Environment. By decree of 23 June 2022, the Ministry of Ecological Transition ordered their revision (Minimum Environmental Criteria for the awarding of design and execution services for building works). CAM aims to facilitate the inclusion of eco-sustainability requirements in tenders for public operations. The aim is to stimulate purchases that minimise the use of natural resources and energy consumption levels, which also contribute towards the spread of renewable sources, reducing waste production, polluting emissions into the air, water and soil, and which eradicate environmentally hazardous substances. Thanks to a sustainable environmental management system, to the EPD certification and in accordance with international standard ISO 14021, Italgraniti contributes towards quality construction with performance levels above the industry average.

Les Critères environnementaux minimum (CAM) sont les conditions environnementales et écologiques définies par le ministère de l'Environnement. Avec le décret du 23 juin 2022, le ministère de la Transition écologique italien a demandé leur révision (Critères environnementaux minimum pour confier un service de conception et d'exécution des travaux d'intervention du bâtiment). Les CAM visent à faciliter l'insertion de conditions de durabilité dans les appels d'offres pour les interventions publiques. L'objectif est de stimuler des achats qui minimisent l'utilisation de ressources naturelles et la consommation d'énergie, qui contribuent également à la diffusion de sources renouvelables, qui réduisent la production de déchets, les émissions polluantes dans l'air, dans l'eau et dans le sol et qui éliminent les substances dangereuses pour l'environnement. Grâce à un système de management environnemental durable, à la certification PED et en accord avec la norme internationale ISO 14021, Italgraniti contribue à construire un secteur du bâtiment de qualité et à fournir des performances au-dessus de la moyenne du secteur.

Ongreening.com provides detailed information about the conformity and contribution of Italgraniti Group products to the main building sustainability certification systems (LEED®, BREEAM®, WELL™, CAM and others).

Ongreening.com fournit des informations détaillées sur la conformité et la contribution des produits Italgraniti Group aux principaux systèmes de certification de la durabilité des bâtiments (LEED®, BREEAM®, WELL™, CAM et autres).

## ONGREENING



For more info visit:  
Ongreening.com



## Product and company system certifications

### MOCA Compliance



I prodotti Italgraniti Group sono conformi ai requisiti previsti dal Regolamento (CE) n. 1935/2004 (Regolamento Quadro sui MOCA) e dalle normative specifiche applicabili, come la Direttiva 85/500/CE, aggiornata dalla Direttiva 2005/31/CE e recepita dal D.Lgs. 04/04/1985 con i successivi aggiornamenti, incluso il Decreto del 1° febbraio 2007. Ogni prodotto è inoltre accompagnato dalla Dichiarazione di Conformità, che ne attesta l'idoneità e la sicurezza. Tale attestazione si basa sui test eseguiti, sulle valutazioni tossicologiche e sull'applicazione delle Buone Pratiche di Fabbricazione (GMP) lungo l'intero processo produttivo, come richiesto dal Regolamento (CE) n. 2023/2006.

Die Produkte der Italgraniti Group entsprechen den Anforderungen der Verordnung (EG) Nr. 1935/2004 (Rahmenverordnung über Lebensmittelkontaktmaterialien) und den geltenden spezifischen Vorschriften, wie der Richtlinie 85/500/EG, aktualisiert durch die Richtlinie 2005/31/EG und umgesetzt durch das Gesetzesdekret vom 04.04.1985 mit den nachfolgenden Aktualisierungen, einschließlich des Dekrets vom 1. Februar 2007. Jedes Produkt wird außerdem von einer Konformitätserklärung begleitet, die seine Eignung und Sicherheit bescheinigt. Diese Bescheinigung basiert auf den durchgeführten Tests, den toxikologischen Bewertungen und der Anwendung der Guten Herstellungspraxis (GMP) während des gesamten Produktionsprozesses, wie in der Verordnung (EG) Nr. 2023/2006 vorgeschrieben.

Italgraniti Group products comply with the requirements of Regulation (EC) No. 1935/2004 (Framework Regulation on MOCA) and specific applicable regulations, such as Directive 85/500/EC, updated by Directive 2005/31/EC and implemented by Legislative Decree 04/04/1985 with subsequent updates, including the Decree of February 1, 2007. Each product is also accompanied by a Declaration of Conformity, which certifies its suitability and safety. This certification is based on tests performed, toxicological assessments, and the application of Good Manufacturing Practices (GMP) throughout the entire production process, as required by Regulation (EC) No. 2023/2006.

Les produits Italgraniti Group sont conformes aux exigences prévues par le Règlement (CE) n° 1935/2004 (règlement-cadre sur les MOCA) et aux réglementations spécifiques applicables, telles que la directive 85/500/CE, mise à jour par la directive 2005/31/CE et transposée par le décret législatif 04/04/1985 avec ses mises à jour ultérieures, y compris le décret du 1er février 2007. Chaque produit est également accompagné d'une déclaration de conformité qui atteste de son aptitude et de sa sécurité. Cette attestation est basée sur les tests effectués, les évaluations toxicologiques et l'application des bonnes pratiques de fabrication (BPF) tout au long du processus de production, comme l'exige le règlement (CE) n° 2023/2006.



Il marchio CE garantisce la sicurezza del prodotto. Un prodotto con il marchio CE è conforme a tutti i parametri di sicurezza e di tutela del consumatore previsti dalla direttiva europea di riferimento. Il marchio CE si ottiene attraverso il superamento di test di laboratorio e la presentazione di un fascicolo tecnico che descrive le prestazioni dei prodotti in esame, in accordo col Regolamento (UE) n. 305/2011 (noto come Regolamento CPR) e con la norma armonizzata UNI EN 14411 ("Piastrelle di ceramica - Definizioni, classificazione, caratteristiche e marcatura").

Das CE-Zeichen garantiert die Produktsicherheit. Ein CE-gekennzeichnetes Produkt entspricht allen Sicherheits- und Verbraucherschutzparametern der entsprechenden europäischen Richtlinie. Die CE-Kennzeichnung wird durch das Bestehen von Labortests und die Einreichung eines technischen Dokuments, in dem die Leistung der geprüften Produkte beschrieben wird, gemäß der Verordnung (EU) Nr. 305/2011 (bekannt als CPR-Verordnung) und der harmonisierten Norm UNI EN 14411 („Keramische Fliesen - Definitionen, Klassifizierung, Merkmale und Kennzeichnung“) vergeben.

The CE mark guarantees product safety. A product with CE mark complies with all the safety and consumer protection parameters of the relevant European directive. The CE mark is obtained by passing laboratory tests and submitting a technical file describing the performance of the products under examination, in accordance with Regulation (EU) no. 305/2011 (known as the CPR Regulation) and the harmonised standard UNI EN 14411 ("Ceramic tiles - Definitions, classification, characteristics and marking").

Le marquage CE garantit la sécurité du produit. Un produit portant le marquage CE est conforme à tous les paramètres de sécurité et de protection des consommateurs prévus par la directive européenne de référence. Le marquage CE est obtenu après des essais de laboratoire et la présentation d'un dossier technique décrivant les performances des produits évalués, conformément au règlement (UE) n° 305/2011 (souvent appelé Règlement CPR) et à la norme harmonisée UNI EN 14411 ("Carreaux céramiques - Définitions, classification, caractéristiques et marquage").



Si tratta di un marchio di qualità francese ottenuto sulla base dei test previsti dalla normativa europea EN 14411 e dai Cahiers tecnici del CSTB. A ogni articolo viene assegnata una classificazione che ne attribuisce l'idoneità alla posa nei diversi ambienti di destinazione. I prodotti certificati e i relativi Classements sono specificati nel certificato.

Es handelt sich um ein französisches Qualitätszeichen, das auf der Grundlage von Prüfungen nach der europäischen Norm EN 14411 und den Technischen Berichten des CSTB vergeben wird. Jedem Artikel wird eine Klassifizierung zugewiesen, die seine Eignung für die Installation in den verschiedenen Zielumgebungen angibt. Die zertifizierten Produkte und ihre Klassifizierungen sind im Zertifikat angegeben.

This is a French quality mark obtained on the basis of tests according to the European standard EN 14411 and the CSTB's Technical Cahiers. Each product is assigned a classification that attributes its suitability for installation in the various target environments. The certified products and their Classements are specified in the certificate.

Il s'agit de la marque de qualité française obtenue sur la base des essais prévus par la norme européenne EN 14411 et les cahiers techniques du CSTB. Chaque article se voit attribuer un classement qui en autorise la pose dans différents espaces de destination. Les produits certifiés et les différents classements sont précisés dans le certificat.



Il prestigioso marchio d'origine Ceramics of Italy contrassegna solamente i prodotti realizzati in Italia, che rappresentano i valori appartenenti all'industria ceramica da decenni. ITALGRANITI GROUP sostiene il codice etico di Confindustria Ceramica che, dalla produzione 100% Made in Italy alla responsabilità sociale e ambientale, promuove una politica industriale seria e trasparente.

Das prestigeträchtige Herkunftszeichen „Ceramics of Italy“ kennzeichnet nur in Italien hergestellte Produkte, die die Werte repräsentieren, die seit Jahrzehnten zur Keramikindustrie gehören. ITALGRANITI GROUP unterstützt den Ethikkodex von Confindustria Ceramica, der von der 100%igen Made in Italy-Produktion bis zur sozialen und ökologischen Verantwortung eine seriöse und transparente Industriepolitik fördert.

Ceramics of Italy is the certified brand of origin which exclusively marks all products fully manufactured in Italy representing the decades old values system of the Italian Ceramic Industry. We support all those values promoted by the Confindustria Ceramica code of ethics, from 100% Italian production to social and environmental responsibility.

La prestigieuse marque d'origine « Ceramics of Italy » désigne uniquement les produits fabriqués en Italie, qui représentent les valeurs de l'industrie céramique depuis des décennies. ITALGRANITI GROUP soutient le code éthique de Confindustria Ceramica qui, de la production 100 % Made in Italy à la responsabilité sociale et environnementale, encourage une politique industrielle sérieuse et transparente.



La marcatura CCC è regolata da una normativa cinese che attesta che i prodotti di ITALGRANITI GROUP possiedono la più bassa radioattività naturale possibile per i materiali edili, inferiore persino alla naturale radioattività dei graniti. La certificazione CCC si ottiene dopo un test incrociato effettuato da due differenti laboratori sullo stesso campione e un audit dell'ente di certificazione che garantisce la conformità al criterio dei prodotti certificati. Il marchio CCC suddivide i prodotti in due classi: A e B. Tutti i prodotti ITALGRANITI GROUP appartengono alla classe A, che è la più sicura, indicata all'utilizzo in tutti i luoghi, compresi quelli pubblici (come scuole e asili).

Die CCC-Kennzeichnung wird durch eine chinesische Verordnung geregelt, die bescheinigt, dass die Produkte der ITALGRANITI GROUP die geringstmögliche natürliche Radioaktivität für Baumaterialien aufweisen, die sogar niedriger ist als die natürliche Radioaktivität von Granit. Die CCC-Zertifizierung erfolgt nach einer Gegenprobe, die von zwei verschiedenen Labors an derselben Probe durchgeführt wird, und einem Audit durch die Zertifizierungsstelle, das garantiert, dass die zertifizierten Produkte das Kriterium erfüllen. Das CCC-Label teilt die Produkte in zwei Klassen ein: A und B. Alle Produkte der ITALGRANITI GROUP gehören zur Klasse A, der sichersten Klasse, die für den Gebrauch an allen Orten geeignet ist, auch an öffentlichen Orten (wie Schulen und Kindergärten).

Le marquage CCC est régi par une norme chinoise et certifie que les produits d'ITALGRANITI GROUP possèdent la plus faible radioactivité naturelle possible pour les matériaux de construction, inférieure même à la radioactivité naturelle des granits. La certification CCC est obtenue après un essai croisé effectué par deux laboratoires différents sur le même échantillon et un audit de l'organisme de certification qui garantit la conformité au critère des produits certifiés. Le marquage CCC divise les produits en deux catégories : A et B. Tous les produits ITALGRANITI GROUP appartiennent à la catégorie A, la plus sûre, indiquée pour une utilisation dans tous les lieux, y compris les lieux publics (écoles ou crèches par exemple).

The CCC marking is governed by a Chinese regulation certifying that ITALGRANITI GROUP's products have the lowest possible natural radioactivity for building materials, lower even than the natural radioactivity of granite. The CCC certification is obtained after cross-testing by two different laboratories on the same sample and an audit by the certification body guaranteeing that the certified products comply with the criterion. The CCC mark divides the products into two classes: A and B. All ITALGRANITI GROUP products belong to class A, which is the safest, suitable for use in all places, including public places (such as schools and kindergartens).



Portiamo con orgoglio in tutto il mondo materiali che esprimono al meglio la cultura estetica, l'eccellenza stilistica e tecnica del Made in Italy. Sul mercato internazionale, il nostro nome è sinonimo di grès porcellanato dalle altissime prestazioni tecniche ed estetiche e attraverso la trasformazione di materie prime di assoluta qualità otteniamo progetti ceramici capaci d'interpretare le molteplici esigenze di un mondo in costante evoluzione.

Wir sind stolz darauf, Materialien im die ganze Welt zu liefern, die die ästhetische Kultur, die stilistische und technische Exzellenz des Made in Italy am besten zum Ausdruck bringen. Auf dem internationalen Markt ist unser Name ein Synonym für Feinsteinzeug von höchster technischer und ästhetischer Leistung. Durch die Verarbeitung von Rohstoffen höchster Qualität entstehen Keramikprojekte, die in der Lage sind, die vielfältigen Anforderungen einer Welt in ständiger Entwicklung zu interpretieren.

Around the world, we proudly promote materials that best express that Made in Italy aesthetic, style and technical excellence. On the international market, our name is synonymous with porcelain stoneware that offers extremely high technical and aesthetic performance. We transform top quality raw materials into ceramic projects able to interpret the many requirements of a continuously evolving world.

Nous portons fièrement, partout dans le monde, des matériaux qui expriment parfaitement la culture esthétique et l'excellence stylistique et technique du meilleur Made in Italy. Sur le marché international, notre nom est synonyme de grès cérame aux performances techniques et esthétiques élevées et, à travers la transformation de matières premières de qualité exceptionnelle, nous obtenons des projets céramiques en mesure d'interpréter les nombreuses exigences d'un monde en perpétuelle évolution.



Website

## Pezzi speciali spessore 9 mm / 9 mm thick special trims



COLLEZIONI COLLECTIONS	Gradone con toro A (*) Step tread with full skirting florentiner stufe / nez de marche avec retombee	Gradone con toro Step tread with full skirting florentiner stufe / nez de marche avec retombee	Gradino (1) Step tread stufenplatte / nez de marche	Battiscopa (1) Skirting Sockel / Plinthe	Elemento "I" (*) Vcap rectified Winkelplatte kalibriert / Rebord rectifié	
Marble Effect	Calcis	120x33x4 cm 47 <sup>1/4</sup> "x13 <sup>3/4</sup> "		7x60 cm 2 <sup>3/4</sup> "x23 <sup>1/2</sup> " / 7x120 cm 2 <sup>3/4</sup> "x47 <sup>1/4</sup> "	4,5x16,5x60 cm 1 <sup>3/4</sup> "x6 <sup>1/2</sup> "x23 <sup>1/2</sup> "	
	Marble Touch	120x33x4 cm 47 <sup>1/4</sup> "x13 <sup>3/4</sup> "		7x60 cm 2 <sup>3/4</sup> "x23 <sup>1/2</sup> " / 7x120 cm 2 <sup>3/4</sup> "x47 <sup>1/4</sup> "		
	I Travertini	120x33x4 cm 47 <sup>1/4</sup> "x13 <sup>3/4</sup> "		7x60 cm 2 <sup>3/4</sup> "x23 <sup>1/2</sup> " / 7x120 cm 2 <sup>3/4</sup> "x47 <sup>1/4</sup> "	4,5x16,5x60 cm 1 <sup>3/4</sup> "x6 <sup>1/2</sup> "x23 <sup>1/2</sup> "	
	Charm Experience	120x33x4 cm 47 <sup>1/4</sup> "x13 <sup>3/4</sup> "		7x60 cm 2 <sup>3/4</sup> "x23 <sup>1/2</sup> "		
	Lux Experience	120x33x4 cm 47 <sup>1/4</sup> "x13 <sup>3/4</sup> "		7x60 cm 2 <sup>3/4</sup> "x23 <sup>1/2</sup> "		
	Marble Experience	120x33x4 cm 47 <sup>1/4</sup> "x13 <sup>3/4</sup> "	60x33x4 cm 23 <sup>1/2</sup> "x13 <sup>3/4</sup> "	7x60 cm 2 <sup>3/4</sup> "x23 <sup>1/2</sup> "		
	Natural	120x33x4 cm 47 <sup>1/4</sup> "x13 <sup>3/4</sup> "		7x60 cm 2 <sup>3/4</sup> "x23 <sup>1/2</sup> " / 7x120 cm 2 <sup>3/4</sup> "x47 <sup>1/4</sup> "	4,5x16,5x60 cm 1 <sup>3/4</sup> "x6 <sup>1/2</sup> "x23 <sup>1/2</sup> " / 4,5x16,5x120 cm 1 <sup>3/4</sup> "x6 <sup>1/2</sup> "x47 <sup>1/4</sup> "	
	Dorset	120x33x4 cm 47 <sup>1/4</sup> "x13 <sup>3/4</sup> "		7x60 cm 2 <sup>3/4</sup> "x23 <sup>1/2</sup> " / 7x120 cm 2 <sup>3/4</sup> "x47 <sup>1/4</sup> "	4,5x16,5x60 cm 1 <sup>3/4</sup> "x6 <sup>1/2</sup> "x23 <sup>1/2</sup> "	
	Origins	120x33x4 cm 47 <sup>1/4</sup> "x13 <sup>3/4</sup> "		7x60 cm 2 <sup>3/4</sup> "x23 <sup>1/2</sup> "	4,5x16,5x60 cm 1 <sup>3/4</sup> "x6 <sup>1/2</sup> "x23 <sup>1/2</sup> "	
	Shale	120x33x4 cm 47 <sup>1/4</sup> "x13 <sup>3/4</sup> "		7x60 cm 2 <sup>3/4</sup> "x23 <sup>1/2</sup> "	4,5x16,5x60 cm 1 <sup>3/4</sup> "x6 <sup>1/2</sup> "x23 <sup>1/2</sup> " / 4,5x16,5x120 cm 1 <sup>3/4</sup> "x6 <sup>1/2</sup> "x47 <sup>1/4</sup> "	
Stone Effect	Silver Grain	120x33x4 cm 47 <sup>1/4</sup> "x13 <sup>3/4</sup> "		7x60 cm 2 <sup>3/4</sup> "x23 <sup>1/2</sup> "	4,5x16,5x60 cm 1 <sup>3/4</sup> "x6 <sup>1/2</sup> "x23 <sup>1/2</sup> "	
	Ceppo di Grè	120x33x4 cm 47 <sup>1/4</sup> "x13 <sup>3/4</sup> "		7x60 cm 2 <sup>3/4</sup> "x23 <sup>1/2</sup> "		
	Nordic Stone	120x33x4 cm 47 <sup>1/4</sup> "x13 <sup>3/4</sup> "		7x60 cm 2 <sup>3/4</sup> "x23 <sup>1/2</sup> "	4,5x16,5x60 cm 1 <sup>3/4</sup> "x6 <sup>1/2</sup> "x23 <sup>1/2</sup> "	
	Stone Mix			7x60 cm 2 <sup>3/4</sup> "x23 <sup>1/2</sup> "	4,5x16,5x60 cm 1 <sup>3/4</sup> "x6 <sup>1/2</sup> "x23 <sup>1/2</sup> "	
	Colour Effect	I Cementi	120x33x4 cm 47 <sup>1/4</sup> "x13 <sup>3/4</sup> "		7x60 cm 2 <sup>3/4</sup> "x23 <sup>1/2</sup> " / 7x120 cm 2 <sup>3/4</sup> "x47 <sup>1/4</sup> "	4,5x16,5x60 cm 1 <sup>3/4</sup> "x6 <sup>1/2</sup> "x23 <sup>1/2</sup> " / 4,5x16,5x120 cm 1 <sup>3/4</sup> "x6 <sup>1/2</sup> "x47 <sup>1/4</sup> "
		Terre	120x33x4 cm 47 <sup>1/4</sup> "x13 <sup>3/4</sup> "		7x60 cm 2 <sup>3/4</sup> "x23 <sup>1/2</sup> "	4,5x16,5x60 cm 1 <sup>3/4</sup> "x6 <sup>1/2</sup> "x23 <sup>1/2</sup> "
		Metaline	120x33x4 cm 47 <sup>1/4</sup> "x13 <sup>3/4</sup> "		7x60 cm 2 <sup>3/4</sup> "x23 <sup>1/2</sup> "	
		Nuances	120x33x4 cm 47 <sup>1/4</sup> "x13 <sup>3/4</sup> "		7x60 cm 2 <sup>3/4</sup> "x23 <sup>1/2</sup> "	4,5x16,5x60 cm 1 <sup>3/4</sup> "x6 <sup>1/2</sup> "x23 <sup>1/2</sup> "
	Wood Effect	Essence Select	120x33x4 cm 47 <sup>1/4</sup> "x13 <sup>3/4</sup> "		6,5x120 cm 2 <sup>5/8</sup> "x47 <sup>1/4</sup> "	4,5x10,5x60 cm 1 <sup>3/4</sup> "x4 <sup>1/2</sup> "x23 <sup>1/2</sup> "
		Essence	120x33x4 cm 47 <sup>1/4</sup> "x13 <sup>3/4</sup> "	120x30 cm 47 <sup>1/4</sup> "x11 <sup>7/8</sup> "	6,5x120 cm 2 <sup>5/8</sup> "x47 <sup>1/4</sup> "	4,5x10,5x60 cm 1 <sup>3/4</sup> "x4 <sup>1/2</sup> "x23 <sup>1/2</sup> "
Allure		120x30x4 cm 47 <sup>1/4</sup> "x11 <sup>7/8</sup> "x1 <sup>3/4</sup> "		6,5x120 cm 2 <sup>5/8</sup> "x47 <sup>1/4</sup> "		
Alnus		120x33x4 cm 47 <sup>1/4</sup> "x13 <sup>3/4</sup> "		6,5x120 cm 2 <sup>5/8</sup> "x47 <sup>1/4</sup> "		

La lavorazione artigianale può portare a leggere differenze dimensionali tra un pezzo e l'altro. / The characteristics of these special pieces are such that differences between two pieces may arise and cannot be contested in any way. / Die handwerkliche Verarbeitung könnte zu sehr leichten massabweichungen führen. / La réalisation artisanale peut présenter des légères différences de dimension d'une pièce à l'autre.

(\*) Assemblato / Coupled / Zusammengebaut / Assemblé

(1) Finitura a becco di civetta / Rounded edge finish / Ausführung mit eckabrundung / Finition a bord arrondi

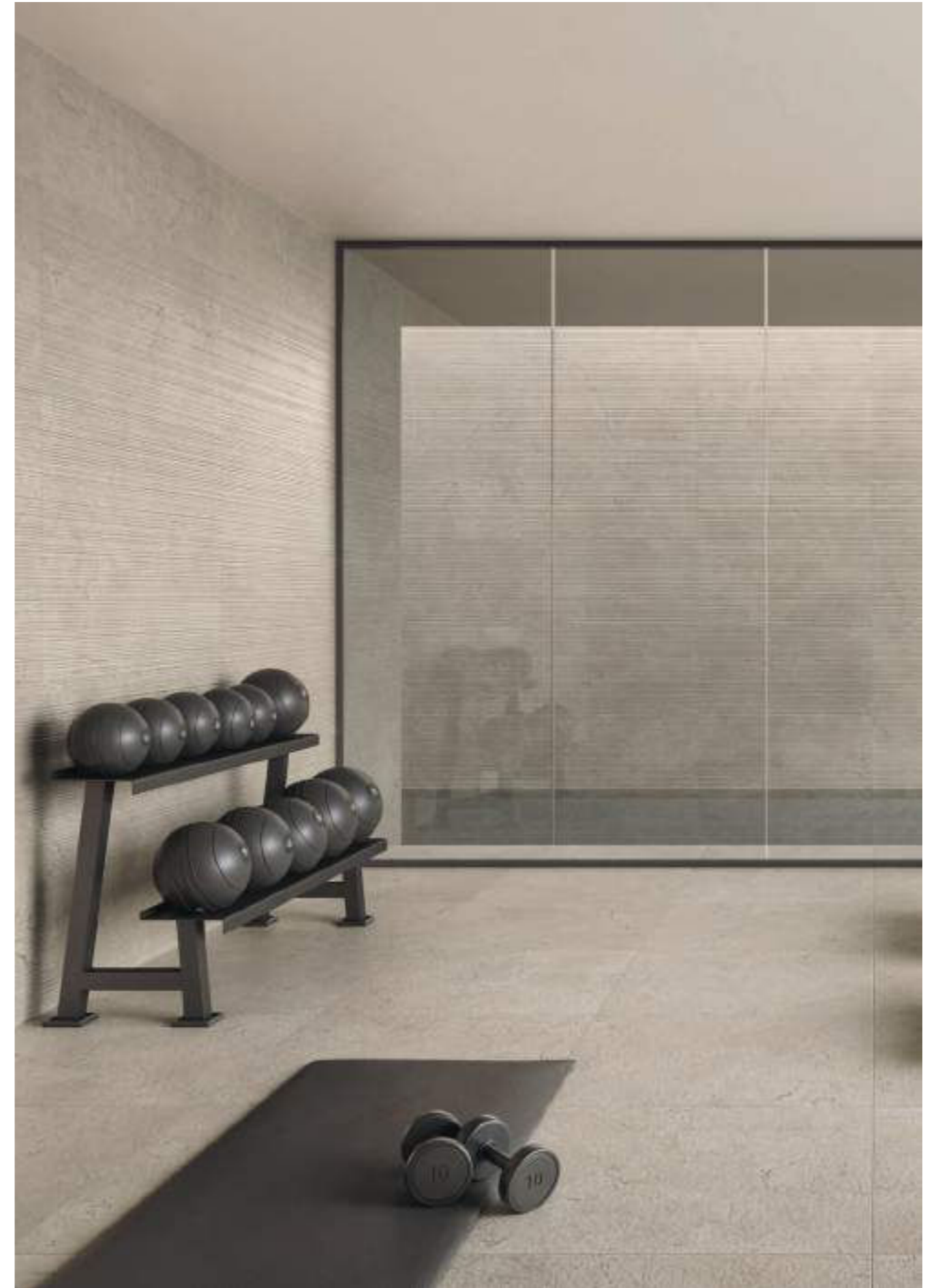

Calcis Corda Stripe 120x60, Corda 80x80

# Pezzi speciali spessore 20 mm / 20 mm thick special trims

## Lavorazioni dei bordi / Edge processing

### Assemblato / Assembled

Zusammengebaut / Assemblé

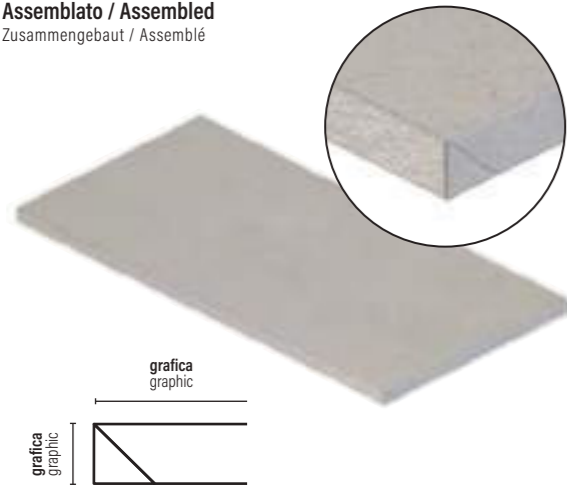

### Toro / Bullnose

Vorderkante / Bord rond

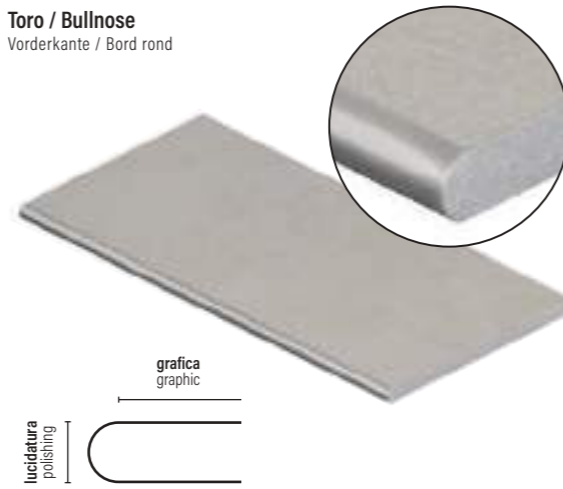

### Costa lucida / Polished edge

Rechtwinklich geschliffen / Coté brillant

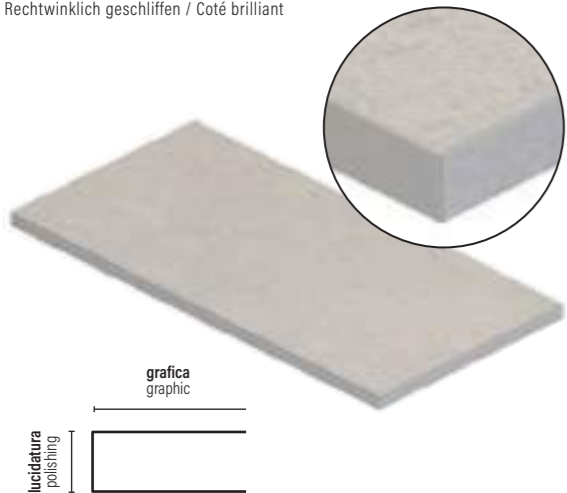

### Veletta "L" / "L" shape element

Schenkelplatte / Margelle avec retombé

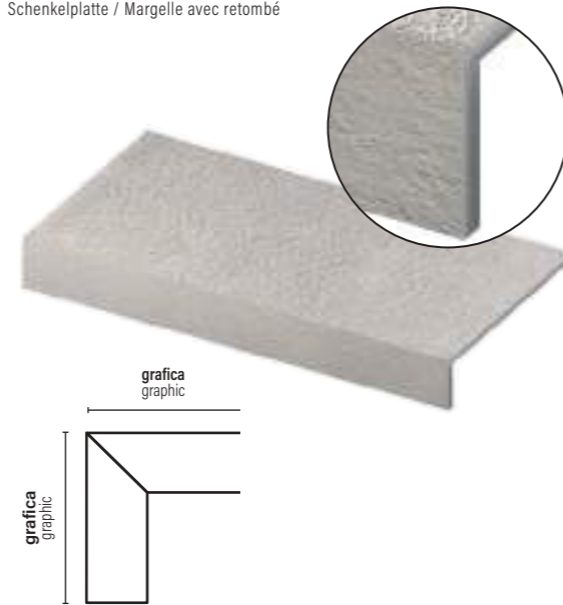

## Articoli / Items

### Assemblati / Assembled

Zusammengeklebt / Assemblés

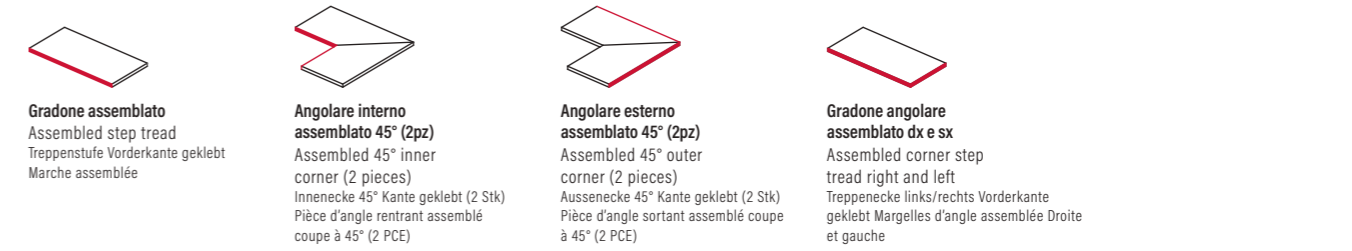

### Toro / Bullnose

Vorderkante / Bord rond

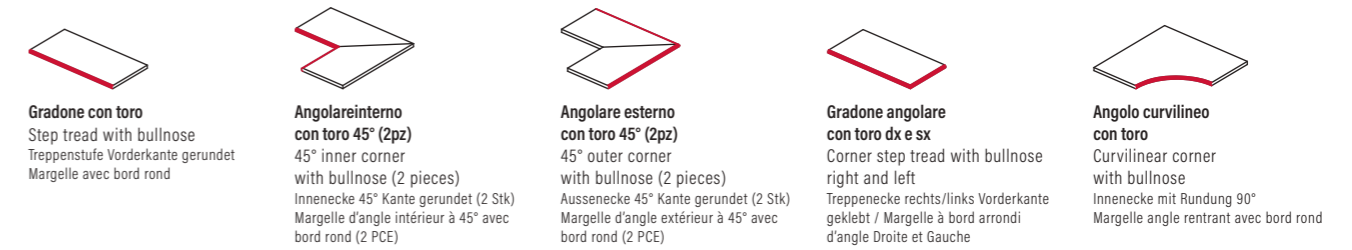

### Costa lucida / Polished edge

Rechtwinklich geschliffen / Coté brillant

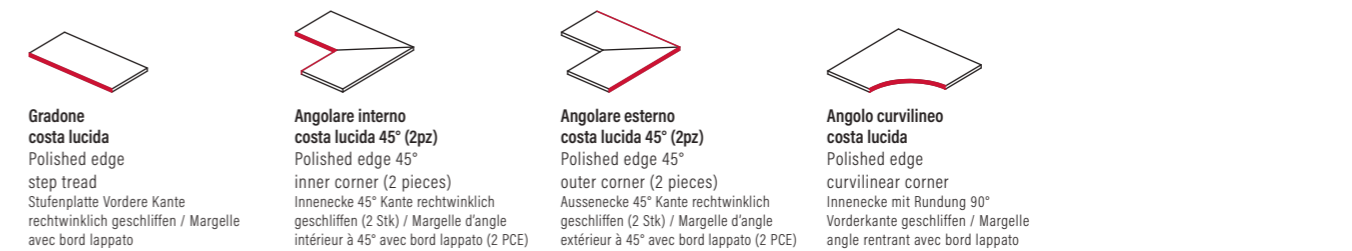

### Veletta "L" / "L" shape element

Schenkelplatte / Margelle avec retombé

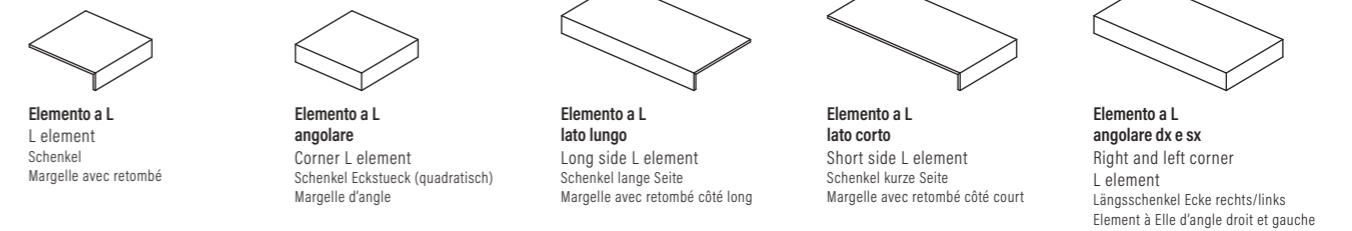

### Accessori / Accessory

Zubehoer / Accessoires

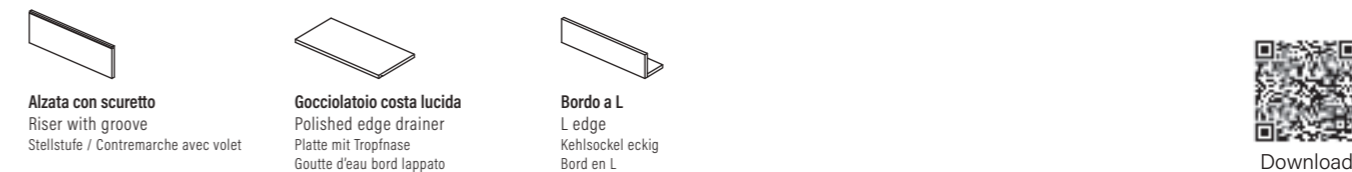
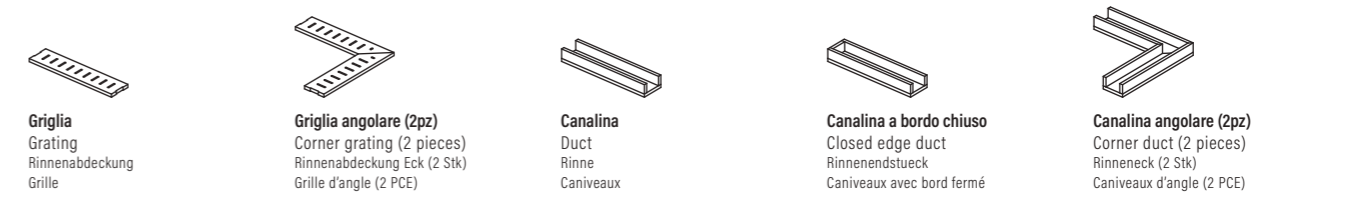

### 20 mm Open - Pezzi speciali / Special pieces

Per approfondimenti sui pezzi speciali e tutti gli accessori per esterno 20mm scarica la scheda tecnica oppure consultare il nostro sito e il catalogo Open.

For further information on special pieces and all 20mm outdoor accessories download the technical data sheet or consult our website and the Open catalog.

Für weitere Informationen zu Sonderteilen und dem gesamten 20mm Outdoor Zubehör laden Sie das technische Datenblatt herunter oder besuchen Sie unsere Website und den Open Katalog.

Pour approfondissements sur les pièces de finition et accessoires pour extérieurs en 20mm merci de télécharger la fiche technique ou bien consulter notre site web et le catalogue OPEN.



## Pezzi speciali spessore 20 mm / 20 mm thick special trims

Soluzioni per piscina / Pool solutions

### Posa con angolo retto / 90° angle installation

Rechtwinklige Verlegung / Pose à angle droit

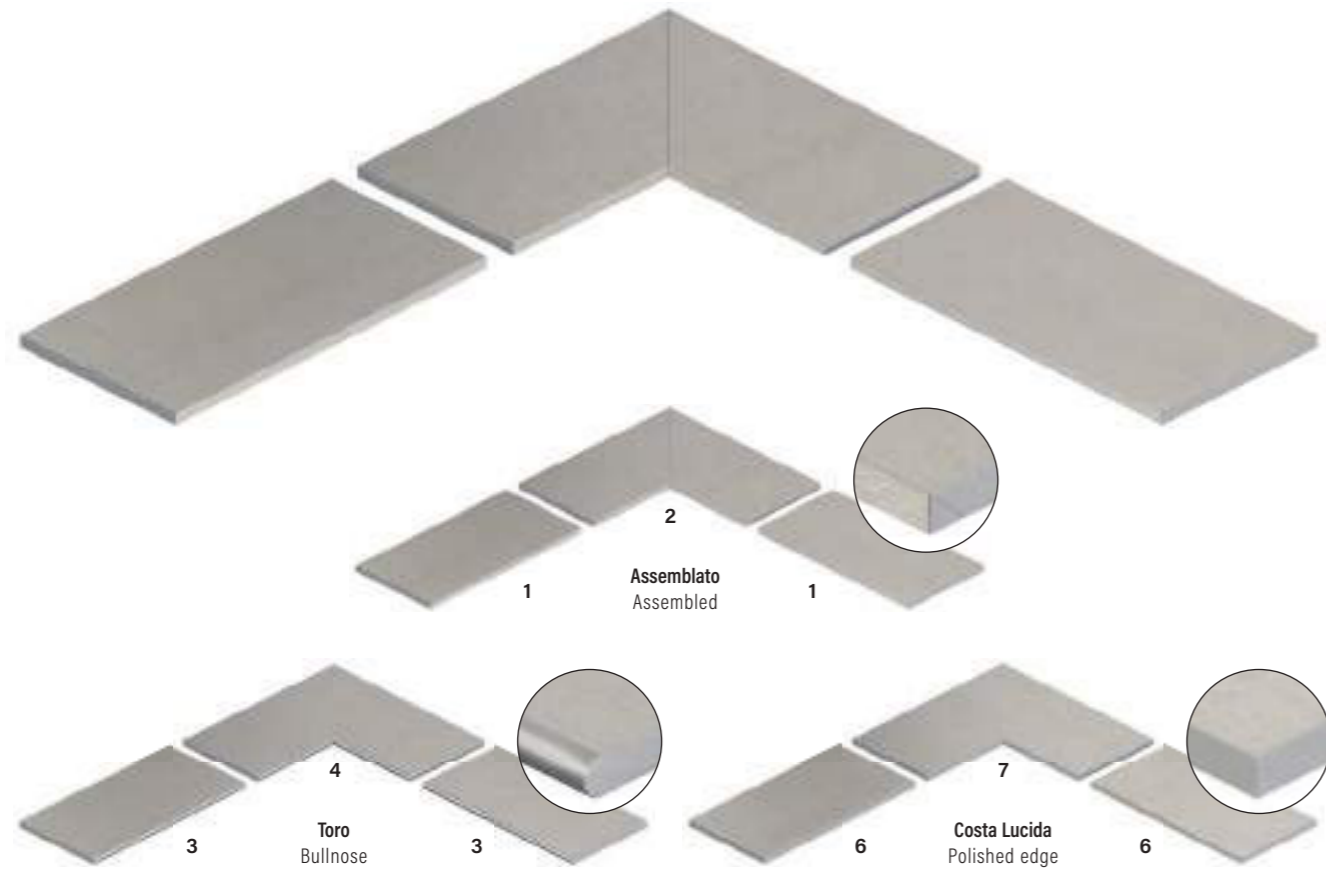

### Posa con angolo curvilineo / Round corner installation

Verlegung Ecke gerundet / Pose avec angle rond

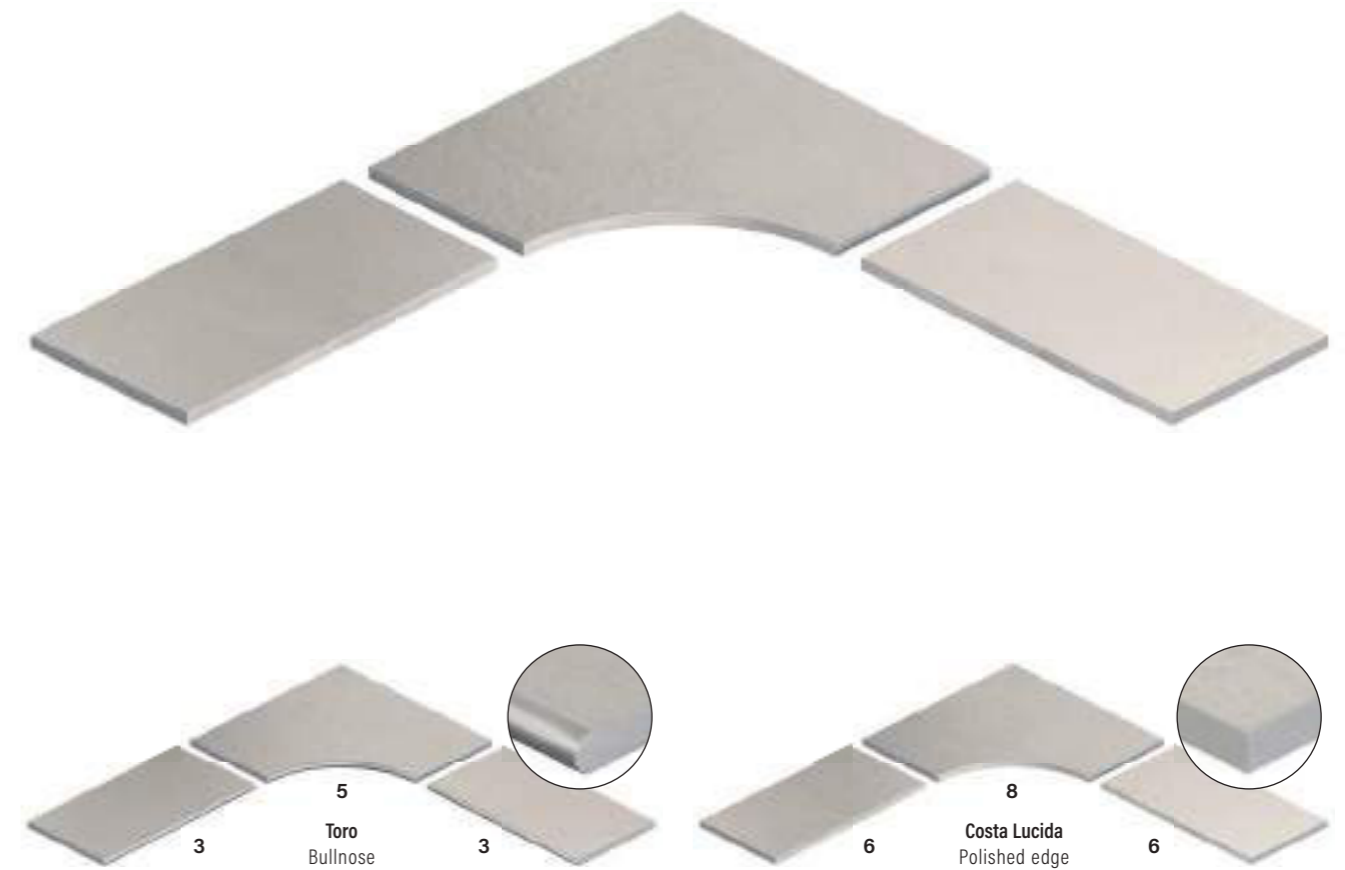

### Legenda pezzi speciali / Special trims summary

Übersicht Sonderstücke / Descriptive piece de finition

- |  |   |   |
|--|---|---|
| <p><b>1. Gradone assemblato</b><br/>Assembled step tread<br/>Treppenstufe Vorderkante geklebt<br/>Marche assemblée</p> <p><b>2. Angolare interno assemblato 45° (2pz)</b><br/>Assembled 45° inner corner (2 pieces)<br/>Innenecke 45° Kante geklebt (2 Stk)<br/>Pièce d'angle rentrant assemblé coupe à 45° (2 PCE)</p> <p><b>3. Gradone con toro</b><br/>Step tread with bullnose<br/>Treppenstufe Vorderkante gerundet<br/>Margelle avec bord rond</p> <p><b>4. Angolare interno con toro 45° (2pz)</b><br/>45° inner corner with bullnose (2 pieces)<br/>Innenecke 45° Kante gerundet (2 Stk)<br/>Margelle d'angle intérieur à 45° avec bord rond (2 PCE)</p> | <p><b>5. Angolo curvilineo con toro</b><br/>Curvilinear corner with bullnose<br/>Innenecke mit Rundung 90°<br/>Margelle angle rentrant avec bord rond</p> <p><b>6. Gradone costa lucida</b><br/>Polished edge step tread<br/>Stufenplatte Vordere Kante rechtwinklich geschliffen<br/>Margelle avec bord lappato</p> <p><b>7. Angolare interno costa lucida 45° (2pz)</b><br/>Polished edge 45° inner corner (2 pieces)<br/>Innenecke 45° Kante rechtwinklich geschliffen (2 Stk)<br/>Margelle d'angle intérieur à 45° avec bord lappato (2 PCE)</p> <p><b>8. Angolo curvilineo costa lucida</b><br/>Polished edge curvilinear corner<br/>Innenecke mit Rundung 90° Vorderkante geschliffen<br/>Margelle angle rentrant avec bord lappato</p> | <p><b>9. Canalina / Duct</b><br/>Rinne / Caniveaux</p> <p><b>10. Canalina angolare (2pz)</b><br/>Corner duct (2 pieces)<br/>Rinneneck (2 Stk) / Caniveaux d'angle (2 PCE)</p> <p><b>11. Canalina a bordo chiuso</b><br/>Closed edge duct<br/>Rinnenendstueck<br/>Caniveaux avec bord fermé</p> <p><b>12. Griglia / Grating</b><br/>Rinnenabdeckung / Grille</p> <p><b>13. Griglia angolare (2pz)</b><br/>Corner grating (2 pieces)<br/>Rinnenabdeckung Eck (2 Stk)<br/>Grille d'angle (2 PCE)</p> |
|--|---|---|

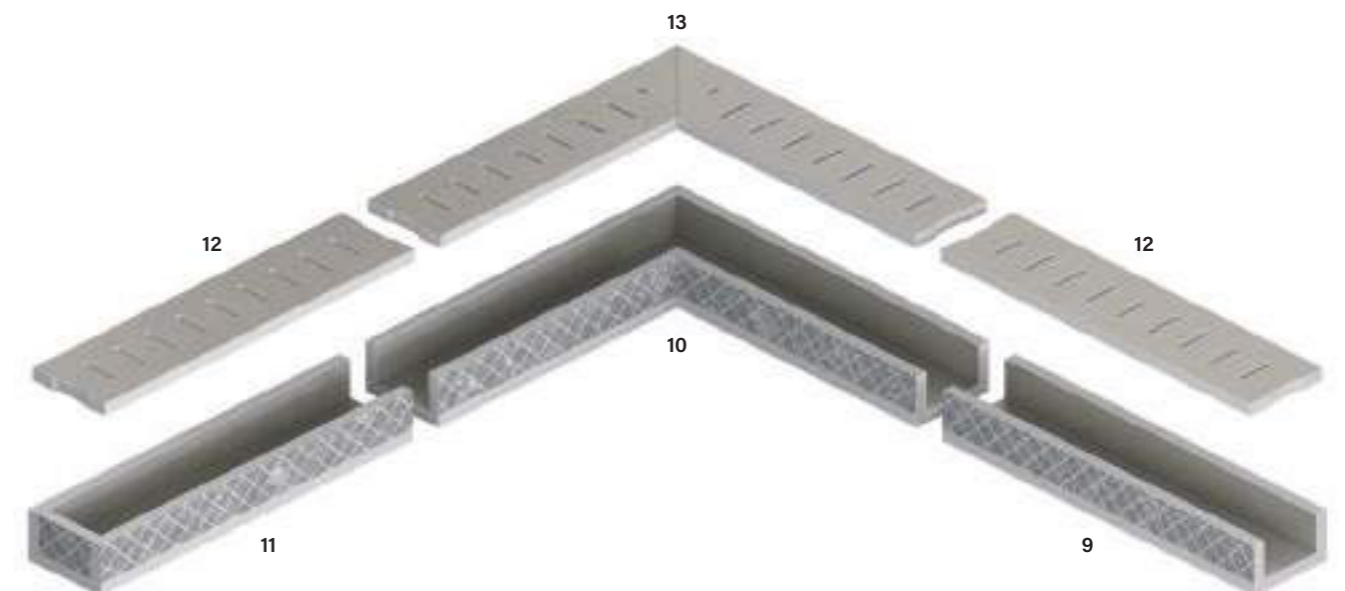

## Pezzi speciali spessore 20 mm / 20 mm thick special trims

Soluzioni per scale, terrazze e gardening / Gardening, stairs and terraces solutions

### Posa gradini ad angolo / Corner step tread installation

Eckstufen verlegung / Pose de marche avec angle

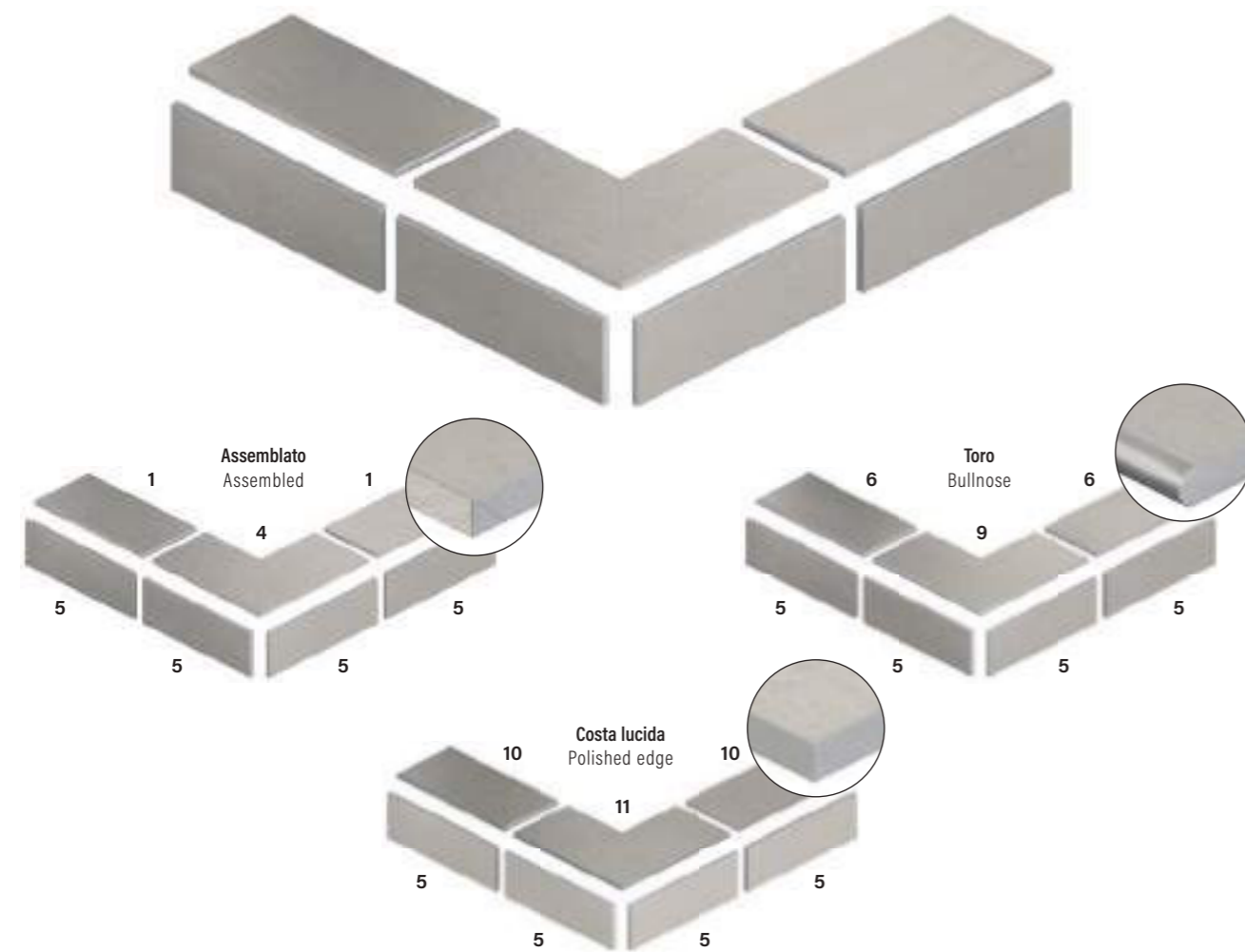

### Posa gradini lineari e terrazze / linear step treads and terraces layout

Lineare Stufen und Terrassenverlegung / Pose nez de marche et terrasse

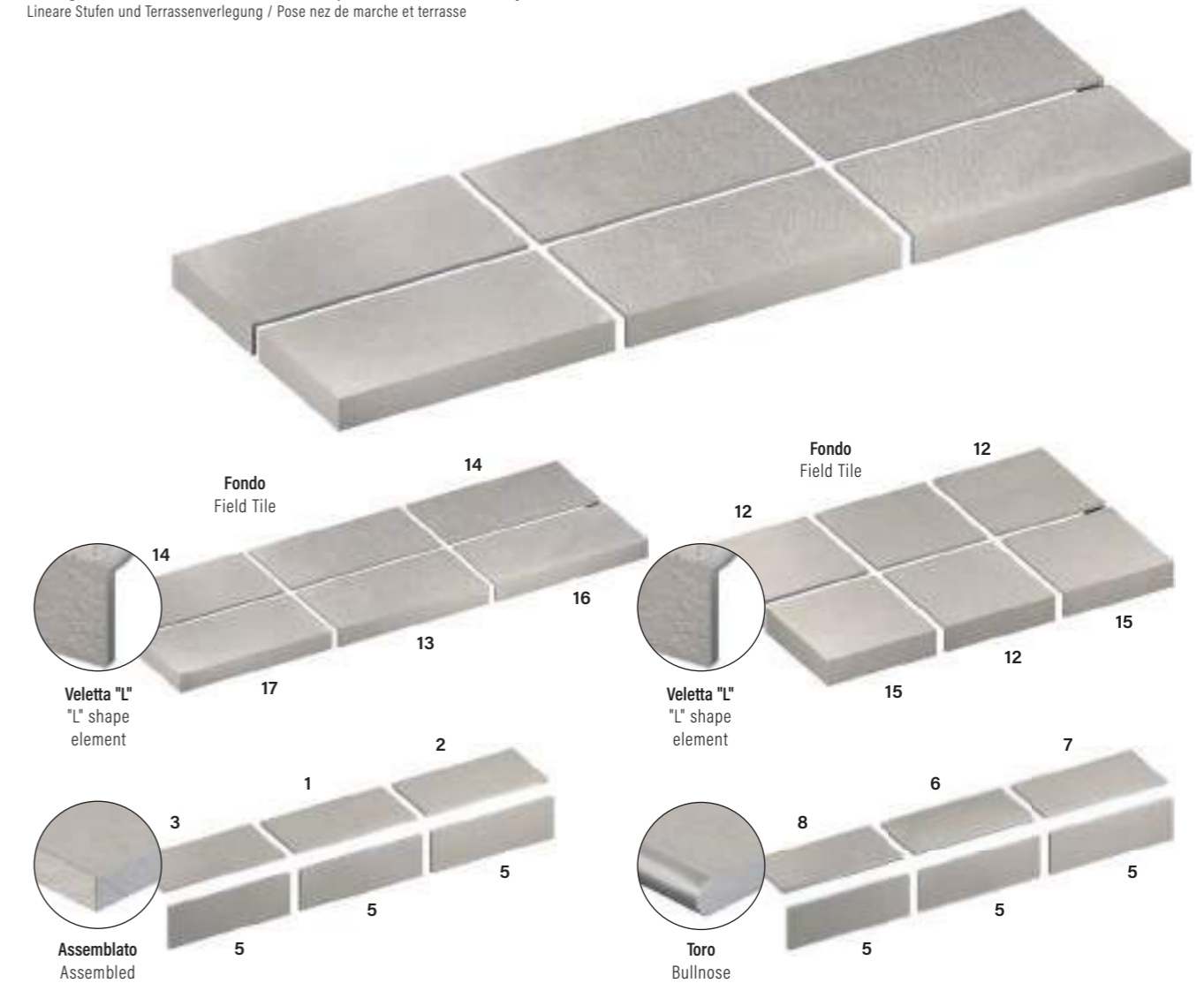

### Legenda pezzi speciali / Special trims summary

Übersicht Sonderstücke / Descriptive piece de finition

- |   |  |  |
|---|--|--|
| <p><b>1. Gradone assemblato</b><br/>Assembled step tread<br/>Treppenstufe Vorderkante geklebt<br/>Marche assemblée</p> <p><b>2. Gradone angolare assemblato dx</b><br/>Assembled right corner step tread<br/>Treppenecke rechts Vorderkante geklebt<br/>Marche d'angle droit assemblée</p> <p><b>3. Gradone angolare assemblato sx</b><br/>Assembled left corner step tread<br/>Treppenecke links Vorderkante geklebt<br/>Marche d'angle gauche assemblée</p> <p><b>4. Angolare esterno assemblato 45° (2pz)</b><br/>Assembled 45° outer corner (2 pieces)<br/>Aussenecke 45° Kante geklebt (2 Stk)<br/>Pièce d'angle sortant assemblée coupe à 45° (2 PCE)</p> <p><b>5. Alzata con scuretto</b><br/>Riser with groove<br/>Stellstufe<br/>Contremarche avec volet</p> | <p><b>6. Gradone con toro</b><br/>Step tread with bullnose<br/>Treppenstufe Vorderkante gerundet<br/>Margelle avec bord rond</p> <p><b>7. Gradone angolare con toro dx</b><br/>Right corner step tread with bullnose<br/>Treppenecke rechts Vorderkante gerundet<br/>Margelle d'angle droit avec bord rond</p> <p><b>8. Gradone angolare con toro sx</b><br/>Left corner step tread with bullnose<br/>Treppenecke links Vorderkante gerundet<br/>Margelle d'angle gauche avec bord rond</p> <p><b>9. Angolare esterno con toro 45° (2pz)</b><br/>45° outer corner with bullnose (2 pieces)<br/>Aussenecke 45° Kante gerundet (2 Stk)<br/>Margelle d'angle extérieur à 45° avec bord rond (2 PCE)</p> <p><b>10. Gradone costa lucida</b><br/>Polished edge step tread<br/>Stufenplatte Vordere Kante rechtwinklich geschliffen<br/>Margelle avec bord lappato</p> | <p><b>11. Angolare esterno costa lucida 45° (2pz)</b><br/>Polished edge 45° outer corner (2 pieces)<br/>Aussenecke 45° Kante rechtwinklich geschliffen (2 Stk)<br/>Margelle d'angle extérieur à 45° avec bord lappato (2 PCE)</p> <p><b>12. Elemento a L</b><br/>L element<br/>Schenkel / Margelle avec retombé</p> <p><b>13. Elemento a L lato lungo</b><br/>Long side L element<br/>Schenkel lange Seite<br/>Margelle avec retombé côté long</p> <p><b>14. Elemento a L lato corto</b><br/>Short side L element<br/>Schenkel kurze Seite<br/>Margelle avec retombé côté court</p> <p><b>15. Elemento a L angolare</b><br/>Corner L element<br/>Schenkel Eckstueck (quadratisch)<br/>Margelle d'angle</p> |
|---|--|--|



- |  |  |
|--|--|
| <p><b>16. Elemento a L angolare dx</b><br/>Right corner L element<br/>Laengsschenkel Ecke rechts<br/>Margelle d'angle droit avec retombé</p> <p><b>17. Elemento a L angolare sx</b><br/>Left corner L element<br/>Laengsschenkel Ecke links<br/>Margelle d'angle gauche avec retombé</p> | <p><b>18. Bordo a L</b><br/>L edge<br/>Kehlschinkel eckig<br/>Bord en L</p> <p><b>19. Gocciolatoio costa lucida</b><br/>Polished edge Drainer<br/>Platte mit Tropfnase<br/>Goutte d'eau bord lappato</p> |
|--|--|



Download  
special pieces  
collection

# Strumenti di movimentazione / Mega handling tools

## IT Strumenti di movimentazione

Gli strumenti per il sollevamento e la movimentazione delle lastre sono da scegliere in funzione della dimensione della lastra e delle attività da svolgere in cantiere presso il magazzino di stoccaggio, in particolare:

- CARRELLO ELEVATORE CON FORCHE LUNGHE 2,5 MT (ANCHE TRAMITE PROLUNGA).
- BARRE / TELAIO DI MOVIMENTAZIONE CON VENTOSE PER FORMATI FINO A 160x320 CM.

### A MOVIMENTAZIONE TRAMITE CARRELLO ELEVATORE A FORCHE LUNGHE

Per una corretta movimentazione di casse e cavalletti è necessario l'utilizzo di un carrello elevatore a forche con una lunghezza di almeno 2,5 mt, utilizzando eventualmente apposite prolunghie. Per consentire il trasferimento delle lastre in totale sicurezza, verificare che intorno al pallet vi siano spazi sufficienti per le manovre del carrello elevatore.

### B MOVIMENTAZIONE TRAMITE BARRE - TELAIO CON VENTOSE

Per la movimentazione manuale e la successiva posa in opera delle lastre Mega, al fine di garantire sicurezza per gli operatori e integrità delle lastre, è vivamente consigliato l'utilizzo di barre o telaio di movimentazione con ventose di sicurezza dotato di carrello per il trasporto (ideali per lastre di formati fino a 160x320 cm). Su articoli Mega di dimensioni inferiori (esempio 120x120 cm) può essere sufficiente l'utilizzo biventose o monoventose con vuotometro.

## DE Handhabungsgeräte

Die Geräte zum Heben und Handhaben der Platten sind in Funktion der Plattenabmessungen und der auf der Bau-stelle oder im Lagerraum auszuführenden Aktivitäten zu wählen, insbesondere:

- STAPLER MIT 2,5 M GABELLÄNGE (AUCH MITTELS VERLÄNGERUNG).
- TRAGSTANGEN / TRAGRAHMEN FÜR DIE HANDHABUNG MIT SAUGHEBERN FÜR FORMATE BIS 160x320 CM.

### A HANDHABUNG MITTELS STAPLER MIT LANGER GABEL

Für eine korrekte Handhabung von Kisten und Transportböcken ist ein Gabelstapler mit einer Gabellänge von mindestens 2,5 m zu verwenden, die Länge kann ggf. mit Verlängerungen erreicht werden. Um eine Plattenbeförderung in voller Sicherheit zu ermöglichen, ist zu prüfen, dass rund um die Palette ein ausreichender Freiraum für die Manöver des Gabelstaplers vorhanden ist.

### B HANDHABUNG MIT TRAGSTANGEN - TRAGRAHMEN MIT SAUGHEBERN

Für die manuelle Handhabung und anschließende Verlegung der Platten Mega wird zur Gewährleistung der Bediener-sicherheit und des einwandfreien Zustandes der Platten nachdrücklich empfohlen, Tragstangen oder einen Tragrah-men mit Sicherheits-Saughebern zu benutzen, die mit einem Transportwagen ausgestattet sind (ideal für Platten in Formaten bis 160x320 cm). Für Mega-Artikel mit geringen Abmessungen (z.B. 120x120 cm) könnte die Verwendung von Doppelsaughebern oder Einzelsaughebern mit Vakuummeter ausreichend sein.

## EN Handling tools

The equipment to be used for lifting and handling slabs should be chosen on the basis of the slab's size and the intended activities in the construction site or storage warehouse, and may be:

- FORKLIFT TRUCK WITH FORKS 2.5 METRES LONG (WITH THE AID OF EXTENSIONS, IF NECESSARY).
- SUCTION CUP HANDLING BARS / FRAME FOR HANDLING SLABS UP TO SIZE 160x320 CM.

### A HANDLING BY FORKLIFT TRUCK WITH LONG FORKS

For correct handling of crates and A-frames, a forklift truck with fork length at least 2.5 metres is required, with the use of the appropriate extensions if necessary. To ensure that the slabs are transported in complete safety, check that there is sufficient space around the pallet to allow the forklift truck to manoeuvre.

### B HANDLING BY SUCTION CUP HANDLING BARS - FRAME

For manual handling and subsequent positioning of Mega slabs, the use of handling bars / frame with safety suction cups (ideal for slabs size 160x320), with transporter trolley, with crosspieces between the bars if necessary, is strongly recommended to ensure workers' safety and prevent damage to slabs. Smaller Mega articles (e.g. 120x120 cm) can be handled simply with the aid of two double suction-cup lifters for handling smooth or polished materials, or two special single pad vacuum lifters for handling materials with structured surface.

## FR Équipements de manutention

Les équipements de levage et de déplacement des dalles doivent être choisis en fonction des dimensions de celles-ci et des activités à mettre en œuvre sur le chantier et dans l'entrepôt de stockage; on peut mentionner:

- CHARIOT ÉLÉVATEUR DOTÉ DE FOURCHES DE 2,5 m DE LONGUEUR (LE CAS ÉCHÉANT DOTÉES DE RALLONGES).
- BARRES / CHÂSSIS DE MANUTENTION DOTÉS DE VENTOUSES POUR FORMATS JUSQU'À 160x320 cm.

### A DÉPLACEMENT EFFECTUÉ AVEC CHARIOT ÉLÉVATEUR À FOURCHES LONGUES

Pour effectuer correctement le déplacement de caisses et chevalets, il est nécessaire d'utiliser un chariot élévateur doté de fourches d'une longueur d'au moins 2,5 m, en utilisant éventuellement des rallonges prévues à cet effet. Pour permettre le déplacement des dalles en conditions de sécurité absolue, s'assurer de la présence autour de la palette de l'espace nécessaire aux manœuvres du chariot élévateur.

### B DÉPLACEMENT EFFECTUÉ AVEC BARRES/CHÂSSIS À VENTOUSES

Pour le déplacement manuel puis pour la pose des dalles Mega, afin de garantir la sécurité des opérateurs et l'intégrité des dalles, il est vivement recommandé d'utiliser des barres ou des châssis de manutention à ventouses de sécurité dotés de chariot de transport (système idéal pour les dalles de format jusqu'à 160x320 cm). Pour les produits Mega de dimensions inférieures (120x120 cm par exemple), des mono-ventouses ou des ventouses doubles à vide peuvent suffire.

## Strumenti / Tools



**BARRE / TELAIO DI MOVIMENTAZIONE**  
con ventose per formati fino a 160x320 cm.

**SUCTION CUP HANDLING BARS / FRAME**  
for sizes up to 160x320 cm.

**CARRELLO DI MOVIMENTAZIONE**  
predisposto per eseguire la stesura della colla sul retro lastra.

**HANDLING TROLLEYS**  
designed to allow application of adhesive to the back of the slab.

## A Movimentazione tramite carrello elevatore a forche lunghe / Handling by forklift truck with long forks



**IT** Per movimentare correttamente il pallet sul lato lungo si raccomanda di allargare al massimo le forche e di posizionarle al centro del pallet, far presa su tutta la profondità prima di sollevare.

**EN** For correct handling of the pallet on the long side, the forks must be widened to their maximum setting and placed in the centre of the pallet; ensure contact through the entire depth before lifting.

**IT** Per movimentare correttamente il pallet sul lato corto (ad esempio nello scarico dei containers) è raccomandato l'utilizzo di forche lunghe almeno 2,5 mt, questo garantisce una perfetta presa e sicurezza del materiale.

**EN** For correct handling of the pallet on the short side (e.g. when unloading containers), forks at least 2.5 metres long should be used to ensure that the material is held perfectly and safely.

**IT** Per preservare l'integrità delle lastre non sovrapporre volumi diversi sulle casse.

**EN** To prevent damage to slabs, do not stack items of different sizes on top of the crates.

## B Movimentazione tramite barre - telaio con ventose / Handling by suction cup handling bars - frame



**IT 1.** Le lastre 160x320/120x280 cm devono obbligatoriamente essere movimentate da due persone con barre / telaio di movimentazione con ventose.

**EN 1.** Slabs in sizes 160x320/120x280 cm must be handled by two people with the aid of suction cup handling bars / frame.

**IT 2.** Prima della movimentazione accertarsi che le ventose siano fissate e aderiscano perfettamente alla lastra.

**EN 2.** Before handling, ensure that the suction cups are adhering firmly to the slab.



**IT 3.** Sollevare delicatamente la lastra e appoggiarla sul banco di lavoro, oppure ruotarla in posizione verticale e collocarla sul carrello di movimentazione per la stesura della colla.

**EN 3.** Lift the slab gently and place it on the workbench, or turn it to the vertical position and place it on the handling trolley for adhesive application.



Download  
Catalogue

## Consigli di posa Mega / Mega installation guide

### IT Consigli di posa

La posa delle lastre Mega richiede condizioni di posa simili a quelle richieste per lastre in formato e spessore tradizionali. Mega richiede l'utilizzo della tecnica a doppia spalmatura: il collante deve essere applicato sia sul fondo di posa che sul retro della lastra.

#### Posa a pavimento su massetto tradizionale

##### A seguire le principali indicazioni per la fase di posa.

Il sottofondo del pavimento dovrà essere stagionato, planare, ben pulito, non gelato e non eccessivamente caldo. È comunque sempre necessario seguire le istruzioni dei produttori dei materiali per sottofondi e collanti. La superficie dovrà essere perfettamente planare per consentire una posa corretta dei prodotti rettificati di grande formato.

#### Posa a pavimento su materiali preesistenti

##### Posa su ceramica, gres porcellanato, marmo e pietre naturali.

Verificare compattezza, solidità e ancoraggio del materiale preesistente. Il sottofondo deve essere pulito da polvere, residui cementizi, grassi, cere e qualsiasi materiale presente sulla superficie che possa compromettere l'adesione. Per la pulizia del materiale si può utilizzare una soluzione di acqua e soda caustica, con abbondante risciacquo finale. In alternativa procedere con abrasione meccanica della superficie. Rimuovere tutti i residui e procedere con la posa.

##### Posa su legno e parquet.

Verificare compattezza, solidità e ancoraggio del materiale preesistente. Il sottofondo deve essere pulito da polvere, residui cementizi, grassi, cere e qualsiasi materiale presente sulla superficie che possa compromettere l'adesione. Prima di proseguire con la posa è necessario arrivare allo strato grezzo del legno mediante abrasione meccanica. Rimuovere tutti i residui e procedere con la posa.

##### Posa su resina.

Verificare compattezza, solidità e ancoraggio del materiale preesistente. Il sottofondo deve essere pulito da polvere, residui cementizi, grassi, cere e qualsiasi materiale presente sulla superficie che possa compromettere l'adesione. Mediante abrasione meccanica procedere con l'irruvidimento di tutta la superficie, colmare eventuali fessurazioni con materiali idonei. Rimuovere tutti i residui e procedere con la posa.

##### Posa su metallo.

Verificare compattezza, solidità e ancoraggio del materiale preesistente. Il sottofondo deve essere pulito da polvere, residui cementizi, grassi, cere e qualsiasi materiale presente sulla superficie che possa compromettere l'adesione. Rimuovere tutti i residui e procedere con la posa.

#### SUPERFICI LAPPATE

Per preservare la superficie ceramica da sporco e traffico di cantiere si raccomanda di proteggere il pavimento con materiali idonei: questa precauzione è da considerarsi obbligatoria in caso di piastrelle con superficie lucida, più esposte a eventuali graffi o danneggiamenti.

### EN Installation advice

The conditions required for the installation of "MEGA" slabs are similar to those necessary for slabs of traditional size and thickness. Mega slabs must be laid using the double spreading method, with the adhesive applied both to the laying substrate and to the back of the slab.

#### Installation on floor on traditional screed

##### The following are the main guidelines to be followed during installation.

The floor substrate must be cured, flat, thoroughly cleaned, not frozen and not too hot. However, it is also essential to follow the instructions of the producers of the substrate materials and adhesives. The surface must be perfectly flat to allow correct laying of large-sized rectified products.

#### Installation on floor on top of existing materials

##### Installation on top of ceramic or porcelain stoneware tiles, marble or natural stones.

Check that the existing material is firm, solid and securely fixed in place. The substrate must be free from dust, cement residues, greases, waxes and any material on the surface which may prevent bonding. The material can be cleaned with a solution of caustic soda and water, rinsing thoroughly when done. Otherwise, the surface can be mechanically sanded. Remove all residues and proceed with installation.

##### Laying on top of wood and parquet.

Check that the existing material is firm, solid and securely fixed in place. The substrate must be free from dust, cement residues, greases, waxes and any material on the surface which may prevent bonding. Before installation, the surface must be mechanically sanded down to the raw wood. Remove all residues and proceed with installation.

##### Installation on top of resin.

Check that the existing material is firm, solid and securely fixed in place. The substrate must be free from dust, cement residues, greases, waxes and any material on the surface which may prevent bonding. Sand mechanically to roughen the entire surfaces and fill any cracks with suitable materials. Remove all residues and proceed with installation.

##### Installing on top of metal.

Check that the existing material is firm, solid and securely fixed in place. The substrate must be free from dust, cement residues, greases, waxes and any material on the surface which may prevent bonding. Remove all residues and proceed with installation.

#### POLISHED SURFACES

To protect the ceramic surface from building site dirt and traffic, the floor should be protected with suitable materials; this precaution is compulsory for tiles with glossy surfaces, at greater risk of scratching or damage.

### Installation on walls

##### The following are the main guidelines to be followed during installation.

The wall for covering must first be plastered with sand and cement or specific ready-mixed products. However, it is also essential to follow the instructions of the producers of the substrate materials and adhesives. The surface must be perfectly flat to allow correct laying of large-sized rectified products.

#### WALL SUBSTRATE CHARACTERISTICS

Mega slabs can be installed on indoor or outdoor walls, after inspection of the existing substrate to check its suitability. Gypsum plasters and foamed concrete are generally only used for indoor installations; concrete plasters and concrete walls are used for the application of slim thickness porcelain stoneware slabs both indoors and outdoors. In the case of plasters applied over the insulating panels used in thermal insulation jackets, the insulating panels must be reinforced with a galvanised mesh secured with mechanical anchor bolts. For the specifications of the mesh and anchor bolts, refer to the installation instructions of the insulation system supplier. In the case of mixed substrates consisting of a reinforced concrete framework and masonry filling, the wall must be plastered before installation, reinforcing the plaster with a supporting mesh over the joints between the two materials.

As for laying on floors, it is important to check that the substrate is perfectly flat and free from cracks (if cracks are found, remove dust and seal with suitable materials) and firm, and is cured with completion of its natural shrinkage.

### Posa a pavimento su massetto tradizionale / Installation on floor on traditional screed



**IT 1.** Prima di procedere con la posa verificare che il fondo sia perfettamente planare, asciutto e pulito. Utilizzare i collanti descritti miscelati in base alle specifiche indicate nella scheda tecnica del collante prescelto. Si raccomanda l'utilizzo di adesivi cementizi ad alte prestazioni in classe C2 o superiore.



**IT 2.** Distribuire la colla sul pavimento utilizzando l'apposita spatola a denti inclinati (10x10 mm), stendere il collante superando di 5/10 cm la superficie della lastra.



**IT 3.** Una volta distribuito il collante accertarsi che nell'ultima stesura l'andamento delle righe sia sempre e solo in un unico verso (per una stesura a regola d'arte le righe dovrebbero essere in linea con il lato corto della lastra), evitare gli incroci che non favoriscono l'espulsione dell'aria dal centro della lastra.



**IT 4.** Stendere il collante sul retro della lastra utilizzando l'apposita spatola a denti quadrati (3x3 mm) e accertarsi che le righe dell'ultima stesura siano nella stessa direzione di quelle della spalmatura della lastra. Durante la fase di stesura, la lastra dovrà essere in posizione verticale e fissata al telaio di movimentazione con ventose di sicurezza posate sopra al carrello per il trasporto con ruote.

**EN 1.** Before proceeding with final installation, check that the substrate is perfectly flat, dry and clean. Use the adhesives described, mixed in accordance with the instructions provided in the relevant technical information. High performance cement adhesives in class C2 or above should be used.

**EN 2.** Apply the glue to the floor using a serrated trowel with slanted teeth (10x10 mm), spreading the adhesive 5/10 cm beyond the edges of the slab.

**EN 3.** After applying the adhesive, make sure that all the lines created by the last pass of the trowel run in the same direction (theoretically the lines should be parallel to the short side of the slab), taking care to avoid criss-cross lines, which tend to trap air in the centre of the slab.

**EN 4.** Apply the adhesive to the back of the slab using the serrated trowel with square teeth (3x3 mm) and make sure that the adhesive lines in the slab run in the same direction as those created by the last pass of the trowel in the adhesive on the floor. During application, the slab should be vertical, secured to the handling bars / frame with safety suction cups placed on the wheeled transporter trolley.



**IT 5.** Mediante il telaio di movimentazione con ventose di sicurezza accompagnare la lastra in posizione e posarla.



**IT 6.** Con l'apposito battitore a vibrazione (o in alternativa con frattazzo in gomma antirimbazzo) assicurarsi che l'incollaggio della lastra avvenga in modo uniforme. Battere dal centro verso i bordi per favorire l'eliminazione di eventuali sacche d'aria tra la lastra, il collante e il fondo di posa. Non utilizzare martelli o utensili non idonei.



**IT 7.** Come per tutti i formati di grandi dimensioni, si suggerisce l'utilizzo dei distanziatori autolivellanti (levellers) per ottenere un risultato estetico ottimale.



**IT 8.** Si raccomanda di alternare e orientare i pezzi in modo da creare una distribuzione naturale del disegno e delle venature. Si consiglia una stuccatura in tinta con il prodotto, mantenendo una fuga minima di 2 mm (come prevede la normativa europea).

**EN 5.** Use the handling bars / frame with safety suction cups to move the slab into position and lay it in place.

**EN 6.** Use a vibrator for tiles (or alternatively a cushioned plastic hammer) to make sure that the slab is glued evenly to the substrate. Tap from the centre to the edges to assist the venting of any air pockets between the slab, the adhesive and the substrate. Do not use hammers or unsuitable tools.

**EN 7.** As with all large-sized tiles, levellers should be used to ensure the very best result in terms of appearance.

**EN 8.** Alternate and lay out the pieces to create a natural distribution of the pattern and grains. We suggest to match grout colour with slab, using a minimum space of 2 mm when laying a single size (as foreseen by European regulation).

### Posa a rivestimento / Installation on walls



**IT 1.** Prima di procedere con la posa verificare che il fondo sia perfettamente planare, asciutto e pulito. Utilizzare i collanti descritti miscelati in base alle specifiche indicate nella scheda tecnica del collante prescelto. Si raccomanda l'utilizzo di adesivi cementizi ad alte prestazioni in classe C2 o superiore. Si suggerisce l'utilizzo di adesivi a scioglimento verticale nullo (caratteristica identificata dalla lettera T).



**IT 2.** Distribuire la colla sulla parete utilizzando l'apposita spatola a denti inclinati (10x10 mm), stendere il collante superando di 5/10 cm la superficie della lastra.

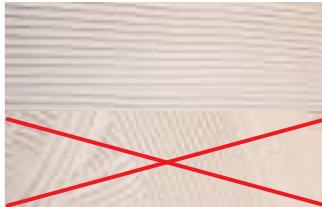

**IT 3.** Una volta distribuito il collante accertarsi che nell'ultima stesura l'andamento delle righe sia sempre e solo in un unico verso (per una stesura a regola d'arte le righe dovrebbero essere in linea con il lato corto della lastra), evitare gli incroci che non favoriscono l'espulsione dell'aria dal centro della lastra.



**IT 4.** Stendere il collante sul retro della lastra utilizzando l'apposita spatola a denti quadrati (3x3 mm) e accertarsi che le righe dell'ultima stesura siano nella stessa direzione di quelle della spalmatura della lastra. Durante la fase di stesura, la lastra dovrà essere in posizione verticale e fissata al telaio di movimentazione con ventose di sicurezza posate sopra al carrello per il trasporto con ruote.

**EN 1.** Before proceeding with final installation, check that the substrate is perfectly flat, dry and clean. Use the adhesives described, mixed in accordance with the instructions provided in the relevant technical information. High performance cement adhesives in class C2 or above should be used. An adhesive with no vertical slip (this characteristic is identified by the letter T) should be used.

**EN 2.** Apply the glue to the wall using a serrated trowel with slanted teeth (10x10 mm), spreading the adhesive 5/10 cm beyond the edges of the slab.

**EN 3.** After applying the adhesive, make sure that all the lines created by the last pass of the trowel run in the same direction (theoretically the lines should be parallel to the short side of the slab), taking care to avoid criss-cross lines, which tend to trap air in the centre of the slab.

**EN 4.** Apply the adhesive to the back of the slab using the serrated trowel with square teeth (3x3 mm) and make sure that the adhesive lines in the slab run in the same direction as those created by the last pass of the trowel in the adhesive on the wall. During application, the slab should be vertical, secured to the handling bars / frame with safety suction cups placed on the wheeled transporter trolley.



**IT 5.** Mediante il telaio di movimentazione con ventose di sicurezza accompagnare la lastra in posizione e posarla.



**IT 6.** Con l'apposito battitore a vibrazione (o in alternativa con frattazzo in gomma antirimbazzo) assicurarsi che l'incollaggio della lastra avvenga in modo uniforme. Battere dal centro verso i bordi per favorire l'eliminazione di eventuali sacche d'aria tra la lastra, il collante e il fondo di posa. Non utilizzare martelli o utensili non idonei.



**IT 7.** Come per tutti i formati di grandi dimensioni, si suggerisce l'utilizzo dei distanziatori autolivellanti (levellers) per ottenere un risultato estetico ottimale.



**IT 8.** Si raccomanda di alternare e orientare i pezzi in modo da creare una distribuzione naturale del disegno e delle venature. Si consiglia una stuccatura in tinta con il prodotto, mantenendo una fuga minima di 2 mm (come prevede la normativa europea).

**EN 5.** Use the handling bars / frame with safety suction cups to move the slab into position and lay it in place.

**EN 6.** Use a vibrator for tiles (or alternatively a cushioned plastic hammer) to make sure that the slab is glued evenly to the substrate. Tap from the centre to the edges to assist the venting of any air pockets between the slab, the adhesive and the substrate. Do not use hammers or unsuitable tools.

**EN 7.** As with all large-sized tiles, levellers should be used to ensure the very best result in terms of appearance.

**EN 8.** Alternate and lay out the pieces to create a natural distribution of the pattern and grains. We suggest to match grout colour with slab, using a minimum space of 2 mm when laying a single size (as foreseen by European regulation).

### Strumenti di posa / Installation equipment



**COLLANTE IN POLVERE A BASE CEMENTIZIA A LETTO PIENO.**  
SOLID BED CEMENT POWDER ADHESIVE.



**SPATOLA A DENTI QUADRATI 3x3 MM PER IL RETRO DELLA LASTRA.**  
3x3 MM SQUARE NOTCH TROWEL FOR BACK OF SLAB.



**SPATOLA A DENTI INCLINATI 10x10 MM PER LA SUPERFICIE SU CUI SI POSA.**  
10x10 MM SLANT NOTCH TROWEL FOR INSTALLATION SUBSTRATE.



**BATTITORE A VIBRAZIONE O FRATTAZZO IN GOMMA ANTRIMBALZO.**  
TILE VIBRATOR OR RUBBER ANTI-BOUNCE BEATER.

# Consigli di posa Mega / Mega installation guide

## DE Verlegungstipps

Die Verlegung der Platten Mega stellt ähnliche Verlegungsbedingungen wie bei Platten in traditionellen Formaten mit traditioneller Dicke. Mega verlangt die Anwendung der doppelten Auftrags-technik: Der Kleber ist sowohl am Verlegungsboden als auch auf der Plattenrückseite aufzutragen.

### Bodenverlegung auf traditionellem Estrich

Es folgen die wichtigsten Anweisungen für die Verlegung.

Der Untergrund des Bodens muss belegreif, eben, ganz sauber, nicht gefroren und nicht zu warm sein. Es sind in jedem Fall stets die Anleitungen der Hersteller der Untergrundmaterialien und Kleber zu befolgen. Die Oberfläche muss perfekt eben sein, um eine korrekte Verlegung der scharfkantigen großformatigen Platten zu gestatten.

### Bodenverlegung auf bereits vorhandenen Materialien

Verlegung auf Keramik, Feinsteinzeug, Marmor und Natursteinen.

Die Kompaktheit, Festigkeit und Verankerung des vorhandenen Materials prüfen. Der Untergrund muss frei von Staub, Zementrückständen, Fett, Wachs und allen sonstigen an der Oberfläche vorhandenen Materialien sein, die das Anhaften beeinträchtigen können. Zur Reinigung des Materials kann eine Lösung aus Wasser und Natron verwendet und abschließend reichlich nachgespült werden. Alternativ kann die Oberfläche mechanisch abgerieben werden. Alle Rückstände entfernen und mit der Verlegung beginnen.

### Verlegung auf Holz und Parkett.

Die Kompaktheit, Festigkeit und Verankerung des vorhandenen Materials prüfen. Der Untergrund muss frei von Staub, Zementrückständen, Fett, Wachs und allen sonstigen an der Oberfläche vorhandenen Materialien sein, die das Anhaften beeinträchtigen können. Vor der Verlegung ist die Rohschicht des Holzes durch mechanisches Abreiben zum Vorschein zu bringen. Alle Rückstände entfernen und mit der Verlegung beginnen.

### Verlegung auf Harz.

Die Kompaktheit, Festigkeit und Verankerung des vorhandenen Materials prüfen. Der Untergrund muss frei von Staub, Zementrückständen, Fett, Wachs und allen sonstigen an der Oberfläche vorhandenen Materialien sein, die das Anhaften beeinträchtigen können. Durch mechanisches Abreiben die ganze Oberfläche aufrauen, eventuelle Schlitzlöcher mit geeigneten Materialien füllen. Alle Rückstände entfernen und mit der Verlegung beginnen.

### Verlegung auf Metall.

Die Kompaktheit, Festigkeit und Verankerung des vorhandenen Materials prüfen. Der Untergrund muss frei von Staub, Zementrückständen, Fett, Wachs und allen sonstigen an der Oberfläche vorhandenen Materialien sein, die das Anhaften beeinträchtigen können. Alle Rückstände entfernen und mit der Verlegung beginnen.

### GELÄPPT OBERFLÄCHEN

Um die Keramikfläche vor Baustellenschmutz und Baustellenbegehung zu schonen, den Boden unbedingt mit geeigneten Materialien schützen: diese Vorkehrung ist für Fliesen mit polierter Oberfläche zwingend vorgeschrieben, da sie eventuellen Kratzern oder Beschädigungen leichter ausgesetzt sind.

## Verlegung als Wandbelag

Es folgen die wichtigsten Anweisungen für die Verlegung.

Die zu verkleidende Wand muss zuvor mit Sand und Zement oder mit spezifischen vorgemischten Produkten verputzt werden. Es sind in jedem Fall stets die Anleitungen der Hersteller der Untergrundmaterialien und Kleber zu befolgen. Die Oberfläche muss perfekt eben sein, um eine korrekte Verlegung der scharfkantigen Großformat-Platten zu gestatten.

### EIGENSCHAFTEN DER WANDUNTERGRÜNDE

Die Platten Mega können auf Innen- oder Außenwänden installiert werden, nachdem die jeweils vorhandenen Untergründe auf ihre Eignung geprüft wurden. Gipsputze und Porenbetonblöcke werden normalerweise nur für die Verlegung in Innenbereichen verwendet; Putze auf Zementbasis und Wände aus Beton werden für die Anbringung von dünnem Feinsteinzeug in Innen- und auch Außenbereichen verwendet. Wenn der Putz auf den typischen Isolierplatten wärmedämmender Ummantlungssysteme aufgebracht wird, sind die Isolierplatten mit einem verzinkten und mit mechanischen Dübeln verankerten Armierungsnetz zu armen. Zu den Spezifikationen von Netz und Dübeln, siehe die Verlegungshinweise des Lieferanten des Isolierungssystems. Dagegen muss die Wand im Falle eines gemischten Untergrundes, d.h. mit Rahmen aus Stahlbeton und Mauerwerkauflagen, vor der Verlegung zuerst verputzt und der Putz im Bereich der Materialübergänge mit Putzarmierungsnetz armiert werden. Wie bei der Bodenverlegung muss geprüft werden, dass der Untergrund perfekt eben, rissfrei (bei Rissen, den Staub beseitigen und mit geeigneten Material versiegeln) und stabil ist und dass seine natürliche Schwindung vollendet ist.

## FR Conseils de pose

La pose des dalles Mega requiert des conditions à peu près identiques à celles requises pour la pose de carreaux de format et épaisseur standard. Les dalles Mega nécessitent le recours à la technique de la double application: le mortier colle doit être appliqué à la fois sur la surface de pose et au dos de la dalle.

### Pose au sol sur chape traditionnelle

Ci-après, sont fournies les principales instructions pour la phase de pose.

La chape doit être sèche, plate, parfaitement propre et non gelée mais non excessivement chaude. Il est dans tous les cas nécessaire de respecter les instructions du fabricant des matériaux pour chapes et mortiers colles. La surface doit être parfaitement plate pour permettre la pose des dalles rectifiées de grand format.

### Pose au sol sur revêtement existant

Pose sur céramique, grès cérame, marbre et pierres naturelles.

S'assurer que le revêtement existant est compact, solide et parfaitement solidaire du support. La surface de pose doit être propre, à savoir exempte de poussière, de résidus de ciment, de graisse, cire et autres susceptibles de compromettre l'adhérence. Pour le nettoyage de la surface, il est possible d'utiliser une solution constituée d'eau et de soude caustique, en procédant ensuite à un abondant rinçage final. Différemment, procéder à un décapage mécanique de la surface. Éliminer tous les résidus et procéder à la pose.

### Pose sur bois et parquet.

S'assurer que le revêtement existant est compact, solide et parfaitement solidaire du support. La surface de pose doit être propre, à savoir exempte de poussière, de résidus de ciment, de graisse, cire et autres susceptibles de compromettre l'adhérence. Avant de procéder à la pose, il est nécessaire que la surface en bois soit brute en procédant à un ponçage. Éliminer tous les résidus et procéder à la pose.

### Pose sur résine.

S'assurer que le revêtement existant est compact, solide et parfaitement solidaire du support. La surface de pose doit être propre, à savoir exempte de poussière, de résidus de ciment, de graisse, cire et autres susceptibles de compromettre l'adhérence. Procéder à un ponçage de telle sorte que toute la surface soit rugueuse et colmater les éventuelles fissures à l'aide d'un matériau approprié. Éliminer tous les résidus et procéder à la pose.

### Pose sur métal.

S'assurer que le revêtement existant est compact, solide et parfaitement solidaire du support. La surface de pose doit être propre, à savoir exempte de poussière, de résidus de ciment, de graisse, cire et autres susceptibles de compromettre l'adhérence. Éliminer tous les résidus et procéder à la pose.

### SURFACES ADOUCIES

Pour protéger la surface céramique des saletés et du trafic de chantier, il est recommandé de protéger le sol à l'aide de matériaux appropriés; cette précaution doit être considérée comme obligatoire dans le cas des carreaux à surface brillante, davantage exposés aux risques de rayures et autres dommages.

## Pose comme revêtement mural

Ci-après, sont fournies les principales instructions pour la phase de pose.

La paroi à revêtir doit être préalablement recouverte d'un enduit à base de sable et de ciment ou d'un enduit spécifique pré-mêlé. Il est dans tous les cas nécessaire de respecter les instructions du fabricant des matériaux pour chapes et mortiers colles. La surface doit être parfaitement plate pour permettre la pose des dalles rectifiées de grand format.

### CARACTÉRISTIQUES DES SURFACES DE POSE MURALE

Les dalles Mega peuvent être posées sur murs intérieurs ou extérieurs, après contrôle de la conformité de la surface de pose existante. Les enduits à base de plâtre et les blocs de béton cellulaire sont généralement destinés à la seule pose en intérieur; les enduits à base de ciment et les murs en béton sont utilisés pour la pose de dalles en grès cérame de faible épaisseur dans les environnements intérieurs et extérieurs. Dans le cas des enduits appliqués sur les panneaux isolants propres aux systèmes d'isolation thermique de type mur-manteau, les panneaux isolants doivent être armés au moyen d'une grille zinguée fixée à l'aide de chevilles mécaniques. Pour les caractéristiques de la grille et des chevilles, se reporter aux indications de pose du fournisseur du système d'isolation. En revanche, dans le cas des supports mixtes constitués d'une structure en béton armé et d'un remplissage en maçonnerie, il est nécessaire d'enduire le mur avant la pose, en dotant l'enduit d'un treillis de soutien à hauteur des variations de matériau. Comme pour la pose au sol, il est nécessaire de s'assurer que le support est parfaitement plat, sans fissures (en présence de fissures, dépoussiérer et colmater les fissures à l'aide d'un matériau approprié) et stable, et qu'il a déjà effectué son retrait naturel.



Download  
Catalogue



Marble Touch Calacatta Top 120x120, Terre Bianco 120x120, Canapa 60x120x2

# Lavorazioni in cantiere Mega / Mega cutting to size on site

## IT Lavorazioni in cantiere

### LAVORAZIONI E TRASFORMAZIONI

Grazie al loro spessore, alle loro caratteristiche tecniche e alle loro dimensioni, le lastre Mega si prestano ad essere lavorate e trasformate per ottenere pezzi speciali o superfici atte a rivestire altri manufatti. Le diverse lavorazioni possono essere effettuate direttamente in cantiere, per progetti singoli e necessità contingenti, oppure prima della posa, affidando l'attività ad aziende tecniche specializzate.

### TAGLIO IN CANTIERE

Mega permette di essere lavorato con grande facilità tramite l'utilizzo di alcuni semplici strumenti. Si consiglia di effettuare le lavorazioni su una superficie piana di lavoro. Per i fori è sufficiente l'impiego di un solo operatore. Per ogni lavorazione è indispensabile seguire fasi definite.

## DE Bearbeitungen auf der Baustelle

### BEARBEITUNGEN UND UMWANDLUNGEN

Dank ihrer Dicke, ihrer technischen Eigenschaften und ihrer Dimensionen eignen sich die Platten Mega für die Bearbeitung und Umwandlung, um Spezialteile zu fertigen oder Oberflächen für die Verkleidung anderer Fabrikate zu erzielen. Die verschiedenen Bearbeitungen können bei Einzelprojekten bzw. nebensächlichen Bedarfsfällen direkt auf der Baustelle erfolgen, oder vor der Verlegung, wobei die Arbeit spezialisierten technischen Unternehmen anzuvertrauen ist.

### SCHNEIDEN AUF DER BAUSTELLE

Mega lässt sich mit wenigen einfachen Geräten besonders leicht bearbeiten. Es wird empfohlen, die Bearbeitungen auf einer ebenen Arbeitsfläche auszuführen. Es wird empfohlen, dass die Schneidarbeiten von mindestens zwei Arbeitern durchgeführt werden. Für die Lochungen genügt ein Arbeiter. Bei jedem Arbeitsgang sind unbedingt bestimmte Phasen zu befolgen.

## EN Cutting to size on site

### SHAPING AND TRANSFORMATION

Thanks to their thickness, technical characteristics and size, Mega slabs are ideal for shaping and transformation to create trim tiles or surfaces for cladding other items. These operations can be carried out directly on site for individual projects or contingent needs, or before installation, by specialist technical firms.

### CUTTING ON THE WORKSITE

Mega slabs can be cut to size very easily with the aid of few simple tools. Slabs should be cut on a flat work surface. Cutting should be performed by at least two workers. Just one worker is sufficient for drilling holes. Preset procedures must be followed for each operation.

## FR Opérations de chantier

### COUPE ET AUTRES OPÉRATIONS

Grâce à leur épaisseur, à leurs caractéristiques techniques et à leurs dimensions, les dalles Mega se prêtent à toutes les opérations de coupe et autres pour obtenir des pièces spéciales ou des surfaces permettant le revêtement d'autres matériaux. Les différentes opérations peuvent être réalisées directement sur le chantier, pour des projets et des besoins spécifiques, ou bien avant la pose en confiant les opérations à une entreprise spécialisée.

### COUPE SUR CHANTIER

Les dalles Mega peuvent être coupées très facilement à l'aide des outils communément utilisés à cet effet. Il est recommandé d'effectuer les opérations de coupe sur un plan de travail plat. Il est recommandé d'effectuer les opérations de coupe à deux. Les perçages peuvent en revanche être réalisés par un seul opérateur. Pour chaque opération, il est indispensable de respecter la procédure prévue.

## Taglio lineare / Straight cutting



### IT 1. TRACCIATURA

• Segnare sulle estremità della lastra la porzione da tagliare.  
• Posizionare la guida da taglio e fare in modo che la rotella posta nel carrello incisore sia posizionata sopra alla traccia per il taglio, bloccare la guida da taglio con carrello incisore attraverso le apposite ventose.

### EN 1. MARKING

• Mark the part to be cut off at the ends of the slab.  
• Position the cutting guide and make sure that the wheel in the scoring carriage is on the cutting mark, then fix the cutting guide in place using the suction cups.



### IT 2. INCISIONE

• Incidere per 5 cm una estremità della lastra spingendo il carrello d'incisione verso il bordo della lastra e replicare nell'estremità opposta.  
• Completare l'incisione unendo i due bordi opposti.  
NB: Avanzare con il carrello d'incisione applicando una pressione costante per tutta la lunghezza del taglio.

### EN 2. SCORING

• Score a length of 5 cm at one end of the slab, pushing the scoring carriage towards the edge of the slab, and repeat at the other end.  
• Complete scoring along the distance between the two opposite edges.  
NB: Move the scoring carriage forward, applying constant pressure throughout the length of the cut.



### IT 3. TRONCATURA

A. Attraverso la guida da taglio spostare la lastra per consentire alla parte incisa di sporgere dal piano di lavoro di 5/10 cm circa.  
B. Sganciare le ventose per muovere verso il centro della lastra la guida da taglio e procedere con la troncatura posizionando la pinza troncatrice in corrispondenza della linea incisa sulla lastra.  
C. Agire con una pressione leggera e progressiva fino a che si noti l'inizio troncatura.  
D. Spostarsi sul bordo opposto e posizionare la pinza troncatrice in corrispondenza della linea incisa sulla lastra e agire con una pressione leggera e progressiva fino a che si noti l'inizio troncatura.  
E. Per completare la troncatura della lastra usare la pinza per esercitare una leggera pressione verso il basso, in corrispondenza di tutta la lunghezza della lastra.

### EN 3. BREAKING OFF

A. Use the cutting guide to move the slab so that the scored part projects 5/10 cm off the work surface.  
B. Release the suction cups to move the cutting guide towards the middle of the slab and start to snap off the slab, positioning the cutting pliers on the line scored in it.  
C. Apply gentle pressure with the pliers and gradually increase until the slab breaks.  
D. Move to the opposite side, place the pliers on the line scored in the slab and apply gentle pressure, gradually increasing until the slab breaks.  
E. To complete the cut, apply a slight downward pressure along the entire length of the slab with the pliers.



### IT 4. FINITURA BORDI

• Lo smussamento degli angoli vivi dovrà essere effettuato attraverso l'apposito tampone diamantato o in alternativa mediante l'uso degli appositi dischi resinosi diamantati.

### EN 4. FINISHING THE EDGES

• Sharp edges must be rounded with a diamond polishing pad or diamond resin bond discs.

## Fori tondi / Round holes



### IT 1. Adagiare la lastra Mega su un banco da lavoro o un supporto compatto e non scivoloso come legno o cemento. Bagnare con acqua l'area dove verrà praticato il foro.

EN 1. Place the Mega slab on a hard, firm, non-slippery surface such as wood or concrete. Wet the area where the hole is to be drilled with water.



IT 2. Eseguire il foro con un'angolazione di 75°-85° e penetrare nella lastra per circa 1-2 mm di profondità.

EN 2. Drill the hole at an angle of 75°-85° to a depth of 1-2 mm into the slab.



IT 3. Mantenere il trapano/avvitatore ad un angolo di 90° e con una pressione delicata e costante effettuare movimenti circolari con un angolo di circa 5°-10°. Non spingere il trapano/avvitatore dritto verso il basso e accertarsi di avere acqua a sufficienza per bagnare la fresa durante tutta la lavorazione.

EN 3. Keep the drill/screwdriver at an angle of 90° and, applying gentle, constant pressure, make circular movements at an angle of about 5°-10°. Do not push the drill/screwdriver straight downwards and make sure that there is sufficient water to keep the tool wet throughout the procedure.



IT 4. Terminata l'operazione pulire da sporco e residui.

EN 4. Clean to remove dirt and residues when done.

## Strumenti / Tools



BARRE / TELAIO DI MOVIMENTAZIONE CON VENTOSE PER FORMATI FINO A 160x320 CM. SUCTION CUP HANDLING BARS / FRAME FOR SIZES UP TO 160x320 CM.



CARRELLO DI MOVIMENTAZIONE PREDISPOSTO PER ESEGUIRE LA STESURA DELLA COLLA SUL RETRO LASTRA. HANDLING TROLLEYS DESIGNED TO ALLOW APPLICATION OF ADHESIVE TO THE BACK OF THE SLAB.



BANCO DI LAVORO. WORKBENCH.



GUIDA DA TAGLIO CON CARRELLO INCISORE PER TAGLI FINO A 320 CM LINEARI E DIAGONALI. CUTTING GUIDE WITH SCORER FOR LINEAR AND DIAGONAL CUTS UP TO 320 CM.



PINZA TRONCATRICE. CUTTER PLIERS.



TRAPANO / AVVITATORE. DRILL / POWER SCREWDRIVER.



FORETTI DIAMANTATI PER FORATURA AD UMIDO (FRESE A TAZZA). DIAMOND CORE DRILLING BITS FOR WET DRILLING.



DISCHI RESINOSI DIAMANTATI E TAMPONI DIAMANTATI PER RIFINIRE I BORDI DOPO L'ESECUZIONE DI TAGLI. RESINOUS DIAMOND DISCS AND DIAMOND PADS FOR FINISHING EDGES AFTER CUTTING.



Download Catalogue

## Imballaggi Mega / Mega Packaging

**IT** I prodotti Mega vengono imballati con sistemi diversi in base al formato.

• Formato **120x280 cm**:  
imballaggio in cassa di legno o in cavalletto.

**DE VERPACKUNG**

Mega-Produkte werden je nach Format mit unterschiedlichen Systemen verpackt.  
• Format 120x280 cm:  
Verpackung in Holzkisten oder -gerüsten.

**EN** Mega products are packaged in different systems depending on the size.

• Size **120x280**:  
packing in a wooden crate or on a stand.

**FR EMBALLAGE**

Les produits Mega sont emballés de différentes manières en fonction du format.  
• Type d'emballage pour les format 120x280 cm:  
caisse en bois ou palette avec support.



## Imballaggi in cassa di legno / Packaging in a wooden crate 120x280 cm

**IT** La cassa di legno è l'imballaggio preferenziale. È possibile impilare fino a 9/10 casse.

**EN** Wooden crates are the preferred packaging. It is possible to stack up to 9/10 crates.

**DE** Die Holzkiste ist die bevorzugte Verpackung. Es können bis zu 9/10 Kisten gestapelt werden.

**FR** La caisse en bois est l'emballage le plus utilisé. Il est possible d'empiler jusqu'à 9-10 caisses.

FORMATO LASTRA / SLAB SIZE	CASSA / CRATE	LASTRA / SLAB		CASSA PIENA / FULL CRATE			PESO CASSA VUOTA / EMPTY CRATE WEIGHT	
		MQ	KG	PZ	MQ	KG		
120x280x0,6 cm 47 1/4"x110 1/4"x1/4"	L 145 x P 292 x H 34	3,36	48,60	20	67,20	1072,00	100	■ 130
120x280x0,6 cm 47 1/4"x110 1/4"x1/4"	L 145 x P 292 x H 27	3,36	48,60	1 / 9	30,24	527,40	90,00	■ 100

## Stoccaggio casse / Crates storage

**IT** Per salvaguardare la conservazione delle casse suggeriamo di impilarle e proteggerle in un luogo coperto; il loro impilaggio, previsto nel carico di camion e container, prevede infatti la foratura del nylon negli angoli, favorendo il contatto dell'acqua piovana con il legno della cassa.

**EN** To keep crates in good condition, they should be stacked and protected in an indoor location; when they are stacked in the normal way for loading trucks and containers, the nylon in the corners is punctured, allowing rainwater to reach the wood of the crate.

**DE** Um den guten Zustand der Kisten aufrecht zu erhalten, empfehlen wir, sie an einem überdachten Ort zu stapeln und zu schützen, denn beim Verladen und Stapeln in den Lkw bzw. Container wird der Nylonschutz an den Ecken ge-locht, was den Kontakt des Kistenholzes mit Regenwasser begünstigt.

**FR** Pour la bonne conservation des caisses, il est recommandé de les empiler et de les protéger à un endroit couvert; leur empilement, prévu pour le chargement sur camion et dans un container, prévoit la perforation du nylon à hauteur des angles, ce qui peut provoquer l'infiltration des eaux de pluie qui peuvent atteindre la caisse en bois.



Download  
Catalogue

# Imballaggi Mega / Mega Packaging

## Imballaggi in cavalletto / Packaging on an a-frame 120x280 cm

**IT** Il cavalletto è un'alternativa selezionata in alcuni casi specifici, a discrezione di Italgraniti, per ottimizzare il carico. Ogni lastra è separata dall'altra da una velina di plastica.

**EN** The stand is a selected alternative in some specific cases, at the discretion of Italgraniti, to optimize the load. Each slab is separated from the others by a plastic sheet.

**DE** Das Gerüst ist in Einzelfällen nach Ermessen von Italgraniti eine ausgewählte Alternative zur Optimierung der Belastung. Jede Platte ist durch eine Kunststoffolie von der anderen getrennt.

**FR** La palette avec support est une alternative choisie dans certains cas spécifiques, à discrétion d'Italgraniti, pour optimiser le chargement. Chaque plaque est séparée des autres par un film plastique.

FORMATO LASTRA / SLAB SIZE	CAVALLETTO / A FRAME	LASTRA / SLAB		CAVALLETTI / A FRAME			CAVALLETTI VUOTI / EMPTY A FRAME WEIGHT	
		MQ	KG	PZ	MQ	KG		
120x280x0,6 cm 47 1/4"x110 1/4"x1/4"	L 75x P 285 x H 153	3,36	48,60	44	147,84	2318,40	180	■ 270



Container 20 piedi / 20' Container - 5,90 x 2,32 x 2,35(h) m		Mq / Sqm	Peso / Weight (Ton)
		6 mm	6 mm
Full 1200x2800 mm	n. 6 cavalletti / stands 1200x2800 mm	887	14,00



Container 40 piedi / 40' Container - 11,90 x 2,32 x 2,35(h) m		Mq / Sqm	Peso / Weight (Ton)
		6 mm	6 mm
Full 1200x2800 mm	n. 12 cavalletti / stands 1200x2800 mm	1774	27,80



Camion, peso massimo caricabile / truck, maximum loadable weight - 30 Ton.		Mq / Sqm	Peso / Weight (Ton)
		6 mm	6 mm
Full 1200x2800 mm	n. 12 cavalletti / stands 1200x2800 mm	1774	27,80
Full 1200x2800 mm	n. 20 casse / crates 1200x2800 mm	1344	21,50



Download  
Catalogue

## Consigli di posa spessore 9 mm / 9 mm thick installation advice

## IT Avvertenze per la posa

### Avvertenze per la posa

Per ottenere il miglior risultato estetico è fondamentale prima della posa stendere a terra almeno 4 mq di prodotto e verificare la distribuzione dell'effetto cromatico.

- Per i formati rettificati si consiglia una fuga di 2 mm
- Per i formati naturali non rettificati si consiglia una fuga di 3 mm

### Consigli di posa

**1) PREPARAZIONE PAVIMENTO/PARETE**

Il sottofondo del pavimento dovrà essere stagionato, planare, ben pulito, non gelato e non eccessivamente caldo. La parete da rivestire dovrà essere preventivamente intonacata a sabbia e cemento o con preparati premiscelati specifici. È comunque sempre necessario seguire le istruzioni dei produttori dei materiali per sottofondi e collanti. La superficie dovrà essere perfettamente planare per consentire una posa corretta dei prodotti rettificati di grande formato.

**2) PREPARAZIONE MATERIALE**

Prima della posa in opera è importante verificare sempre il tono, il calibro e la scelta del materiale.

Non si accettano reclami su materiale già posato i cui difetti siano visibili prima della posa (vedi condizioni generali di vendita).

Si consiglia di stendere preventivamente a terra prelevando il materiale da più scatole per verificare l'effetto d'insieme. Necessario in caso di utilizzo di collezioni ad altro grado di stonalizzazione e miscelazione cromantica.

Tutte le decorazioni e i pezzi speciali devono essere trattati con estrema cura in considerazione dei materiali pregiati con cui sono realizzati. In caso di taglio del materiale è opportuno utilizzare una strumentazione idonea. Si consiglia di maneggiare con cura i materiali, durante queste lavorazioni, per evitare rotture o danni ai bordi. Evitare di segnare il materiale sulla superficie con matite o pennarelli, in particolar modo sui prodotti lappati e levigati.

**3) POSA**

È consigliata una posa con fuga di 2 mm per il prodotto rettificato e di 3 mm per il materiale naturale non rettificato. Si consiglia di posizionare con regolarità dei giunti di dilatazione negli ambienti grandi. È invece sufficiente lasciare un leggero stacco tra il materiale e i muri perimetrali negli ambienti più piccoli. È opportuno seguire il senso di posa indicato sul retro delle piastrelle per ottenere la miglior resa estetica.

### Consigli di posa e manutenzione gres porcellanato "Lappato-Satin, Lappato e Spazzolato"

**LAPPATO-SATIN, LAPPATO E SPAZZOLATO**

Sui prodotti Lappato-Satin, Lappato e Spazzolato, la lavorazione genera piccole microporosità superficiali tali da richiedere un'attenzione particolare in fase di posa. Leggere differenze di lucentezza tra le piastrelle non sono difetti di produzione ma caratteristiche del processo produttivo.

Prima della stuccatura asportare dalle fughe residui di colla e altre impurità. Utilizzare sigillanti in tono con il colore della piastrella, attenendosi alle indicazioni dei produttori. Procedere stuccando e pulendo di volta in volta piccole porzioni di pavimento/parete (5 mq.).

**La pulizia finale è indispensabile.** Va eseguita con prodotti specifici seguendo scrupolosamente le indicazioni dei produttori.

Di norma prima di procedere si prova il detergente su una piccola porzione nascosta di pavimento. Evitare nel modo più assoluto detergenti che contengano acido e derivati, non adatti per le pulizie del gres porcellanato. Dopo la pulizia occorre risciacquare più volte.

**Per l'ottimale mantenimento del pavimento nel tempo** è preferibile limitare l'utilizzo di mezzi abrasivi e sostanze aggressive; per la normale pulizia si consiglia di utilizzare acqua calda e detergenti neutri.

<p><b>SUPERFICI "Lappato-Satin, Lappato e Spazzolato"</b></p> <p>Il gres porcellanato "Lappato-Satin, Lappato e Spazzolato" si ottiene con l'aggiunta superficiale di graniglie di vetro che, in cottura, si fondono in uno strato vetroso compatto e resistente Le superfici così ottenute risultano brillanti e luminose; <b>per preservare queste peculiarità è sempre consigliato proteggere i pavimenti a posa avvenuta, inoltre se ne sconsiglia l'impiego in aree prossime ad uscite esterne o in zone soggette a traffico intenso.</b></p> <p>Per preservare la superficie ceramica da sporco e traffico di cantiere <b>si raccomanda di proteggere il pavimento con materiali idonei: questa precauzione è da considerarsi obbligatoria in caso di piastrelle con superficie "Lappato-Satin, Lappato e Spazzolato",</b> più esposte a eventuali graffi o danneggiamenti.</p>
---

### Leveling system per posa a correre di formati rettangolari

Nel caso si scelga la posa "a correre" dei prodotti in formati rettangolari, si consiglia di sfalsare il lato più lungo per un massimo di 10-15 cm sulla lunghezza del pezzo adiacente. È necessario utilizzare i sistemi di livellamento "Leveling System", in modo particolare nel caso della posa dei formati rettangolari dove la posa sfalsata è spesso richiesta, questi sistemi velocizzano il lavoro, permettono in qualsiasi condizione la planarità del materiale e garantiscono un ottimo risultato estetico.

## EN Installation advice

### Installation advice

For the best results in terms of appearance, before installation it is essential to spread at least 4 m² of product on the floor and check the colour distribution.

- For rectified sizes, joints of 2 mm are recommended
- For natural unrectified sizes, joints of 3 mm are recommended

### Installation advice

**1) PREPARING THE FLOOR/WALL**

The floor substrate must be cured, flat, thoroughly cleaned, not frozen and not too hot. The wall for covering must first be plastered with sand and cement or specific ready-mixed products. However, it is also essential to follow the instructions of the producers of the substrate materials and adhesives.

The surface must be perfectly flat to allow correct laying of large-sized rectified products.

**2) PREPARING THE MATERIAL**

Before installation it is important always to check the shade, working size and grade of the material. No claims are accepted with regard to material already laid with defects visible before installation (see general conditions of sale).

The material from several boxes should be spread on the floor before laying to check the combined effect. This is essential when using collections with a high degree of shade variation and colour mixing.

All decorative tiles and trims must be handled with great care in view of the fine materials from which they are made. If material has to be cut, suitable tools should be used. Materials should be handled with care during these processes to prevent breakages or damage to the edges.

Do not mark the surface of the material with pencils or felt-tip pens, especially on honed and polished products.

**3) INSTALLATION**

A joint of 2 mm is recommended for rectified products, and at least 3 mm for natural unrectified material. In large rooms expansion joints should be left at regular intervals.

In smaller rooms, it is enough to leave a slight gap between the material and the walls around the edges. Tiles should be laid in the direction shown on the back for the most attractive effect.

### Satin-Honed, Honed and Brushed porcelain stoneware installation and care advice

**SATIN-HONED, HONED AND BRUSHED**

The finishing procedure used on Satin-Honed, Honed and Brushed products creates tiny pores in the surface, and special care is therefore needed during installation. Slight differences in shine between tiles are not production defects; they are characteristics of the specific production process.

Before grouting, remove glue residues and other dirt from the joints. Use sealants in a colour which matches the tile, following the producer's instructions. Proceed by grouting and then cleaning small areas of the floor/wall at a time (5 m²).

**Final cleaning is essential.** It must be carried out with specific products, complying strictly with the producer's instructions.

Normally before proceeding the cleaner is tried out on a small, hidden portion of the floor covering. Never use cleaners which contain acids or acid products, which are not suitable for cleaning porcelain stoneware. After cleaning, rinse several times.

**To keep the floor in tip-top condition over time** do not use abrasive utensils or aggressive substances more than absolutely necessary; hot water and neutral cleaners are recommended for routine cleaning.

<p><b>"Satin-Honed, Honed, and Brushed" SURFACES</b></p> <p>The "Satin-Honed, Honed, and Brushed" finish porcelain stoneware is achieved by the superficial addition of glass granules that, during firing, fuse into a compact and resistant vitreous layer. The resulting surfaces are shiny and luminous; to preserve these characteristics, <b>it is always recommended to protect the flooring after installation. Moreover, its use is not advised in areas near exterior exits or zones subject to heavy traffic.</b></p> <p>To protect the ceramic surfaces from building site dirt and traffic, <b>the surface should be protected with suitable materials; this precaution is compulsory for tiles with "Satin-Honed, Honed and Brushed" surfaces,</b> at greater risk of scratching or damage.</p>
---

### Levelling system for running-bond installation of rectangular sizes

When rectangular products are laid in "running bond" patterns, the longest side should be staggered in relation to the length of the piece next to it by no more than 10-15 cm.

Levelling systems must be used, especially when laying rectangular sizes, when staggered joints are often required; these systems speed up the job, allow the material to be laid perfectly flat in all conditions and guarantee an immaculate appearance.

## DE Hinweise für die Verlegung

### Installation advice

Um optimale ästhetische Ergebnisse zu erzielen, ist es grundwichtig, vor der Verlegung mindestens 4 m² des Produktes auf dem Boden auszubreiten und die Verteilung der chromatischen Wirkung zu prüfen.

- Für scharfkantige Formate werden 2 mm-Fugen empfohlen.
- Für nicht scharfkantige, natürliche Formate werden 3 mm-Fugen empfohlen.

### Verlegungstipps

**1) VORBEREITUNG VON BODEN/WAND**

Der Untergrund des Bodens muss belegreif, eben, ganz sauber, nicht gefroren und nicht zu warm sein. Die zu ver-kleidende Wand muss zuvor mit Sand und Zement oder mit spezifischen vorgemischten Produkten verputzt werden. Es sind in jedem Fall stets die Anleitungen der Hersteller der Untergrundmaterialien und Kleber zu befolgen. Die Oberfläche muss perfekt eben sein, um eine korrekte Verlegung der scharfkantigen Großformat-Platten zu ge-statten.

**2) VORBEREITUNG DES MATERIALS**

Vor der Verlegung ist unbedingt der Farbton, das Werkmaß und die Materialwahl zu prüfen.

Es werden keine Reklamationen für bereits verlegtes Material akzeptiert, dessen Fehlerhaftigkeiten schon vor der Verlegung sichtbar waren (siehe allgemeine Verkaufsbedingungen). Es wird empfohlen, die Platten vorher auf dem Boden auszubreiten und sie dazu aus mehreren Schachteln zu ent-nehmen, um die Gesamtwirkung zu prüfen. Dies ist notwendig, wenn Platten mit starken Schattierungen und farbli-chen Mischungen verwendet werden. Alle Dekorationen und Formstücke müssen angesichts der kostbaren Materialien, mit denen sie gefertigt sind, ext-rem sorgfältig behandelt werden.

Falls das Material geschnitten werden muss, ist ein geeignetes Schneidezeug zu verwenden. Bei diesen Bearbeitun-gen ist vorsichtig mit den Platten umzugehen, um Brüche bzw. die Beschädigung der Ränder zu vermeiden. Es ist zu vermeiden, das Material auf der Oberfläche mit Bleistift oder Faserstift zu markieren; dies gilt besonders für geläppte und polierte Produkte.

**3) VERLEGUNG**

Es wird empfohlen, scharfkantige Platten mit 2 mm breiten Fugen zu verlegen und nicht scharfkantige Platten mit 3 mm breiten Fugen. Es wird empfohlen, auf Großflächen regelmäßig Dehnungsfugen einzuplanen. Auf kleinen Flächen genügt es dagegen, zwischen den Platten und Wänden einen geringen Abstand zu halten.

Um das beste optische Ergebnis zu erzielen, sollte die auf der Fliesenrückseite angezeigte Verlegungsrichtung be-folgt werden.

### Empfehlungen für die Verlegung und Instandhaltung von Feinsteinzeug in den Ausführungen "Geläppt-Satin, GEläppt und Gebürstet"

**GELÄPPT-SATIN, GELÄPPT UND GEBÜRSTET**

Auf Produkten in den Ausführungen Geläppt-Satin, Geläppt und Gebürstet erzeugt die Bearbeitung an der Oberflä-che kleine Mikroporositäten, die bei der Verlegung eine besondere Aufmerksamkeit verlangen. Leichte Glanzunter-schiede unter den Fliesen sind keine Produktionsfehler, sondern Eigenschaften des Produktionsprozesses. Vor der Ausfugung sind Klebrückstände und sonstiger Schmutz aus den Fugen zu entfernen. Fugendichtmassen im Farbton der Fliesen verwenden und die Hinweise des Herstellers befolgen. Bei der Ausfugung jeweils immer kleine Boden-/Wandportionen (5 m²) ausfugen und reinigen. **Die Schlussreinigung ist unentbehrlich.** Sie ist mit spezifischen Produkten unter gewissenhafter Befolgung der Herstelleranweisungen durchzuführen.

Normalerweise wird das Reinigungsmittel vor der Reinigung auf einer kleinen, versteckten Bodenportion getestet. Reinigungsmittel, die Säure und Säurederivate enthalten, sind absolut zu vermeiden, denn sie eignen sich nicht für die Reinigung von Feinsteinzeug. Nach der Reinigung mehrmals nachspülen. **Um den optimalen Zustand des Bodens dauerhaft zu erhalten,** sollte die Verwendung von Schleifmitteln und aggressiven Stoffen eingeschränkt werden; für die Normalreinigung wird empfohlen, Warmwasser und Neutralreiniger zu verwenden.

<p><b>OBERFLÄCHEN „Geläppt-Satin, Geläppt und Gebürstet“</b></p> <p>Das Feinsteinzeug „Geläppt-Satin, Geläppt und Gebürstet“ wird durch das oberflächliche Auftragen von Glasgranulät hergestellt, das während des Brennens zu einer kompakten und widerstandsfähigen Glasurschicht verschmilzt. Die daraus resultierenden Oberflächen sind glänzend und strahlend; <b>um diese Eigenschaften zu bewahren, wird empfohlen, die Böden nach der Verlegung zu schützen. Außerdem wird von der Verwendung in Bereichen in der Nähe von Außenausgängen oder in stark frequentierten Zonen abgeraten.</b></p> <p><b>Um die Keramikfläche vor Baustellenschmutz und Baustellenbegehung zu schonen, den Boden unbedingt mit ge-eigneten Materialien schützen: diese Vorkehrung ist für Fliesen mit den Oberflächen „Geläppt-Satin, Geläppt und Gebürstet“ zwingend vorgeschrieben,</b> da sie eventuellen Kratzern oder Beschädigungen leichter ausgesetzt sind.</p>
--

### Leveling System für die fortlaufende Verlegung rechteckiger Formate

Falls rechteckige Formate "fortlaufend" verlegt werden sollen, wird empfohlen, die längere Seite im Verhältnis zum angrenzenden Teil um maximal 10-15 cm versetzt anzuordnen. Es ist notwendig, die „Leveling System“ Nivellierungssysteme zu verwenden, ganz besonders bei der Verlegung rechteckiger Formate, bei denen oft eine versetzte Verlegung verlangt wird. Diese Systeme beschleunigen die Ar-beit, ermöglichen unter allen Bedingungen die Ebenheit des Materials und garantieren ein ausgezeichnetes ästheti-sches Ergebnis.

## FR Recommandations de pose

### Installation advice

Pour obtenir le meilleur résultat esthétique, il est essentiel, avant de procéder à la pose, d'étaler au sol au moins 4 mètres carrés de dalles et de contrôler la répartition de l'effet chromatique.

- Pour les formats rectifiés, il est recommandé de réaliser des joints de 2 mm.
- Pour les formats naturels non rectifiés, il est recommandé de réaliser des joints de 3 mm.

### Consils de pose

**1) PRÉPARATION DU SOL/MUR**

La chape doit être sèche, plate, parfaitement propre et non gelée mais non excessivement chaude. La paroi à revêtir doit être préalablement recouverte d'un enduit à base de sable et de ciment ou d'un enduit spécifique pré-mélangé. Il est dans tous les cas nécessaire de respecter les instructions du fabricant des matériaux pour chapes et mortiers colles. La surface doit être parfaitement plate pour permettre la pose des dalles rectifiées de grand format.

**2) PRÉPARATION DU MATÉRIAU**

Avant de procéder à la pose, il est important de contrôler la couleur, les dimensions de fabrication et le choix du matériau. Aucune réclamation ne saurait être acceptée sur le matériau déjà posé dont les défauts sont visibles avant la pose (voir Conditions générales de vente).

Il est recommandé de poser préalablement au sol le matériau en le prélevant dans plusieurs boîtes pour contrôler l'effet d'ensemble. Cette précaution est nécessaire dans le cas des collections à fortes variations de nuances et de mélange chromatique.

Toutes les décorations et les pièces spéciales doivent être manipulées avec grande précaution compte tenu de la qualité des matériaux avec lesquelles elles sont réalisées.

Pour l'éventuelle coupe des dalles, veiller à utiliser un outil prévu à cet effet. Il est recommandé de manipuler les dalles avec précaution durant ces opérations pour prévenir les risques de ruptures et de dommages sur les bords des dalles.

Éviter de tracer toute marque au crayon de papier ou au feutre sur la dalle, en particulier sur les dalles à finition adoucie et polie.

**3) POSE**

Il est conseillé d'effectuer la pose avec des joints de 2 mm pour les matériaux rectifiés et de 3 mm pour les matériaux naturels non rectifiés. Il est recommandé de mettre en place à intervalles réguliers des joints de dilatation au sein des espaces de grandes dimensions. Dans le cas des espaces de moindres dimensions, il suffit en revanche de laisser un espace entre les carreaux et les murs de pourtour. Il est recommandé de respecter le sens de pose indiqué au dos des carreaux pour obtenir le meilleur effet esthétique.

### Conseils de pose et d'entretien du grès cérame « Adouci Satiné », «Adouci » et « Brossé »

**ADOUCI SATINÉ, ADOUCI ET BROSSÉ**

Sur les produits « Adouci Satiné », « Adouci » et « Brossé », la finition crée des microporosités superficielles qui nécessitent une grande attention pendant la pose. De légères différences de brillant entre les carreaux ne sont pas des vices de fabrication mais des caractéristiques propres au processus de production. Avant de procéder au jointoiment, éliminer des joints les résidus de mortier colle et autres impuretés. Utiliser des produits de jointoiment de la même couleur que celle des carreaux, en veillant à respecter les indications du producteur. Procéder au jointoiment par petites portions de sol/mur (5 mm²), en éliminant au fur et à mesure les quantités excédantes.

**Le nettoyage final est indispensable.** Le nettoyage doit être effectué à l'aide de produits spécifiques en respectant scrupuleusement les indications du producteur.

En règle générale, avant de procéder au nettoyage, tester le détergent sur une petite partie de sol peu visible. Éviter dans tous les cas d'utiliser un détergent contenant de l'acide et ses dérivés: ils ne sont pas adaptés au nettoyage du grès cérame. À l'issue du nettoyage, procéder à plusieurs rinçages.

**Pour le parfait entretien du sol dans le temps,** il est préférable de limiter l'utilisation d'ustensiles abrasifs et de produits corrosifs; pour le nettoyage courant, il est recommandé d'utiliser de l'eau chaude et un détergent neutre

<p><b>SURFACES « Adoucie satinée», « Adoucie » et « Brossée »</b></p> <p>Le grès cérame « Adoucie satinée<span> </span>», « Adoucie » et « Brossée<span> </span>» est obtenu par l'ajout en surface de granulés de verre qui, pendant la cuisson, se fondent en une couche vitrée compacte et résistante. Les surfaces ainsi obtenues sont brillantes et lumineuses<span> </span>; <b>pour préserver ces caractéristiques, il est toujours conseillé de protéger les sols après la pose. De plus, son utilisation est déconseillée dans les zones proches des sorties extérieures ou dans les espaces soumis à un trafic intense.</b></p> <p>Pour protéger la surface céramique des saletés et du trafic de chantier, <b>il est recommandé de protéger le sol à l'aide de matériaux appropriés; cette précaution doit être considérée comme obligatoire dans le cas des carreaux à surface « Adoucie Satinée<span> </span>», « Adoucie<span> </span>» et « Brossée<span> </span>»,</b> davantage exposés aux risques de rayures et autres dommages.</p>
---

### Leveling System pour la pose décalée de formats rectangulaires

Dans le cas de la pose décalée de carreaux rectangulaires, il est recommandé de décaler le côté long d'un maximum de 10-15 cm sur la longueur du carreau adjacent. Il est nécessaire d'utiliser le système de nivellement « Leveling System », en particulier dans le cas des formats rectangulaires dont la pose décalée est souvent requise; ce système permet d'accélérer le travail puisqu'il garantit la planéité du matériau dans toute condition et assure un résultat esthétique irréprochable.



# Stuccatura e pulizia dopo la posa / Grouting and cleaning after installation

## IT Stuccatura e pulizia dopo la posa

Con collanti a presa normale, stuccare il pavimento dopo 24/48 ore, se si utilizzano adesivi rapidi, stuccare dopo 4 ore.

Per i materiali lappati è consigliato l'utilizzo di stucchi cementizi con colori tono su tono, su queste superfici non adoperare stucchi epossidici o malte flessibili a base di materiali sintetici soprattutto se a contrasto col colore del materiale. Non aggiungere additivi/lattici allo stucco, questi prodotti rendono estremamente difficoltosa l'eliminazione dei residui con i normali detergenti per la pulizia. Nel caso si decidesse di procedere con stucchi non consigliati, testarli sempre sul materiale per verificare il risultato.

- Stendere lo stucco con spatola gommata sulla superficie da fugare, prestando attenzione a non lasciare spazi vuoti.
- Stuccare piccole superfici per volta asportando le quantità eccedenti con spugne o stracci inumiditi (di sola acqua pulita), oppure utilizzare apposite macchine, eliminando le eccedenze quando il velo di stucco è ancora umido.

### Pulizia dopo la posa

**I prodotti Italgraniti hanno una superficie resistente alle macchie, igienica e di facile manutenzione, affinché queste caratteristiche siano mantenute è indispensabile effettuare una pulizia accurata appena terminata la posa, eliminando i residui cementizi che creano un film sulla superficie del prodotto in grado di trattenerne maggiormente lo sporco.**

La rimozione inadeguata o tardiva dei residui di malta, collanti e stucchi utilizzati per le fughe, può lasciare aloni difficili da rimuovere.

La pulizia iniziale va quindi effettuata immediatamente dopo la posa, utilizzando prodotti a base acida, strofinando energicamente e sciacquando abbondantemente con acqua. In questo modo sarà possibile eliminare i residui di stucco, collante, cemento, ecc. È possibile utilizzare tutti i detergenti disponibili sul mercato, con unica esclusione dei prodotti contenenti acido fluoridrico (composti e derivati) come previsto dalla norma EN 1441.

Si suggerisce l'uso di un detergente acido ( es: DETERDEK - filasolutions.com).

Per la rimozione dei residui di stucco epossidico si suggerisce l'uso di un detergente alcalino (es.: FILA CR10 - filasolutions.com).

**NB:** Seguire attentamente le istruzioni riportate dal produttore sulla confezione del prodotto impiegato. Prima di procedere alla pulizia della superficie posata, è buona norma fare sempre un test preventivo degli agenti pulenti su un campione del materiale non posato o su un'area limitata e meno visibile.

### Protezione dopo la posa

Per preservare la superficie ceramica da sporco e traffico di cantiere **si raccomanda di proteggere il pavimento con materiali idonei, questa precauzione è da considerarsi obbligatoria in caso di piastrelle con superfici lappate, più esposte a eventuali graffi o danneggiamenti.**

### Pulizia ordinaria

Per la pulizia ordinaria è sufficiente adottare alcune semplici precauzioni, dettate principalmente dal buon senso e dalla conoscenza delle caratteristiche del materiale.

- Utilizzare detergenti neutri, privi di cere, e diluiti in acqua, seguendo sempre le modalità riportate sulle confezioni.
- Per lavaggi frequenti può essere utilizzata semplicemente acqua pulita.
- Non utilizzare prodotti acidi o strumenti aggressivi, che potrebbero opacizzare la superficie dei materiali lappati, e intaccare i materiali a base cementizia utilizzati per sigillare le fughe.
- Si consiglia di prevenire il più possibile la presenza di materiali graffianti provenienti dall'esterno, sabbia quarzifera e altri materiali, possono provocare l'abrasione della superficie con conseguente diminuzione della lucentezza.

#### • FACCIATE VENTILATE

L'isolante posto dietro il paramento di lastre lavora in condizioni ottimali quando è perfettamente asciutto, è buona norma evitare violenti getti di acqua.

Si suggerisce l'uso di un detergente neutro ( es: FILACLEANER - filasolutions.com).

**NB:** Sul prodotto in gres porcellanato **è sconsigliato l'uso di cere, saponi oleosi, impregnanti** (idro-oleorepellenti).

## EN Grouting and cleaning after installation

With normal-setting adhesives, grout the floor after 24/48 hours; with fast-setting adhesives, grout after 4 hours.

For polished materials, use cementitious grouts in matching colours; do not use flexible synthetic mortars on these surfaces, especially in contrasting colours. Do not add additives/latex to the grout, as these products make it extremely difficult to remove residues with ordinary cleaning products. If you decide to use a grout which is not recommended, always test it on the material first to check the result.

- Apply grout over the surface for grouting with a rubber trowel, taking care not to leave any gaps.
- Grout a small area at a time, removing excess with wet sponges or rags (use clean water only), or use the special machines, removing excess while the film of grout is still wet.

### Cleaning after installation

**Italgraniti products have a stain-resistant, hygienic, easy-care surface. To ensure these characteristics, it is essential to clean the material thoroughly immediately after installation, removing the cementitious residues that create a film on the product's surface that may tend to trap dirt.**

Poor or late removal of mortar, adhesive and grout residues may leave streaks and smears which are difficult to remove. Initial cleaning must therefore be carried out immediately after installation, using acidic products, rubbing briskly and then rinsing with plenty of water. This will remove grout, adhesive, cement etc. residues. All commercial cleaners may be used, except for products which contain hydrofluoric acid (compounds and derivatives), as specified by the EN 14411 standard.

**NB:** Take care to follow the instructions provided by the producer on the pack of the product used. Before cleaning the surface installed, it is always best to test the cleaning agents first on a sample of the material which has not been installed, or on a small, not very visible area.

We recommend the use of an acid cleaner (e.g.: DETERDEK - filasolutions.com).

Epoxy grout residues should be removed with an alkaline cleaner (e.g.: FILA CR10 - filasolutions.com) .

### Protection after installation

To protect the ceramic surface from building site dirt and traffic, **the floor should be protected with suitable materials; this precaution is compulsory for tiles with polished surfaces, at greater risk of scratching or damage.**

### Routine cleaning

For routine cleaning, it is enough to follow a few simple precautions which are mainly common sense once the material's characteristics are borne in mind.

- Use neutral, wax-free detergents diluted in water, always following the instructions on the packs.
- Clean water may be sufficient for frequent washes.
- Do not use acid products or hard or sharp tools which may dull the surfaces of polished materials and attack cementitious grouts.
- All possible care should be taken to prevent the presence of material from outdoors which may cause scratches, quartz sand and other materials, since they may cause abrasion of the surface and reduce its shine.
- **VENTILATED FACADES**  
The insulation installed behind the slab covering is most effective when perfectly dry; do not use violent water jets.

We recommend the use of a neutral cleaner ( e.g.: FILACLEANER - filasolutions.com).

**NB: Waxes, oily soaps and impregnating materials (water and oil-repellents) should not be used on porcelain stoneware.**

## DE Verfugung und Reinigung nach der Verlegung

Mit normal aushärtenden Klebern den Boden nach 24/48 Stunden verfugen, bei Verwendung schnell aushärtender Kleber nach 4 Stunden.Bei geläpften Materialien wird empfohlen, zementäre Fugenmörtel mit Ton in Ton Farben zu verwenden; auf solchen Oberflächen keine Epoxy-Fugenmörtel oder flexible Fugenmörtel auf Basis von synthetischen Materialien verwenden, vor allem wenn sie das Material farblich kontrastieren. Dem Fugenmörtel keine Zusatzstoffe/Latex zuschlagen, denn diese Produkte machen die Beseitigung der Rückstände mit herkömmlichen Reinigungsmittel extrem schwierig. Falls man sich für nicht empfohlene Fugenmörtel entscheidet, sind diese immer auf dem Material zu testen, um das Ergebnis zu prüfen.

- Den Fugenmörtel mit einem Gummispachtel auf der zu verfugenden Oberfläche vorsichtig ausbreiten, um keine Stellen leer zu lassen.
- Jeweils immer kleine Oberflächen verfugen und die eventuell überschüssigen Mengen mit Schwämmen oder ange-feuchteten Tüchern (nur mit sauberem Wasser) entfernen, oder entsprechende Maschinen verwenden und die Über-schüsse beseitigen, solange der Mörtelfilm noch feucht ist.

### Reinigung nach der Verlegung

**Die Italgraniti-Produkte besitzen eine fleckbeständige, hygienische und pflegeleichte Oberfläche. Um diese Ei-genschaften aufrecht zu erhalten, muss der Verleger unbedingt sofort nach der Verlegung eine sorgfältige Rei-nigung vornehmen und die Zementrückstände entfernen, die einen stark schmutz-anfälligen Film auf der Produkt-fläche bilden.**

Eine unangemessene oder verspätete Entfernung der Rückstände der verwendeten Mörtel, Kleber und Fugenmörtel kann schwer zu entfernende Ränder hinterlassen. Die Erstreinigung ist somit sofort nach der Verlegung unter Verwendung säurehaltiger Produkte durchzuführen, in-dem die Fläche energisch abzureiben und reichlich mit Wasser nachzuspülen ist. In dieser Weise können die Rück-stände von Fugenmörtel, Kleber, Zement, usw. entfernt werden. Es können alle auf dem Markt erhältlichen Reini-gungsmittel verwendet werden; ausgeschlossen sind nur Produkte, die Fluorwasserstoffsäure (Verbindungen und Derivate) enthalten, laut Bestimmung in der Norm EN 14411.

Es wird zur Verwendung eines säurehaltigen Reinigers empfohlen (z.B: DETERDEK - filasolutions.com). Zur Entfernung der Rückstände von Epoxy-Fugenmörteln wird zur Verwendung eines Alkali-Reinigers empfohlen. (z.B: FILA CR10 - filasolutions.com).

**MERKE:** Die Anleitungen des Herstellers auf der Produktpackung sind aufmerksam zu befolgen.

Vor der Reinigung der verlegten Oberfläche sollte das Reinigungsmittel stets auf einem nicht verlegten Materialmus-ter oder auf einer weniger sichtbaren kleinen Fläche getestet werden.

### Schutzbehandlung nach der Verlegung

Um die Keramikfläche vor Baustellenschmutz und -begehung zu schützen, ist der **Boden unbedingt mit geeigneten Materialien zu schützen. Diese Maßnahme ist für Fliesen mit polierter Oberfläche, die eventuellen Verkratzun-gen oder Beschädigungen leichter ausgesetzt sind, zwingend vorgeschrieben.**

### Normalreinigung

Für die Normalreinigung genügt es, einige einfache Vorsichtsmaßnahmen zu treffen, die hauptsächlich auf Vernünf-tigkeit und auf der Kenntnis der Materialeigenschaften beruhen.

- In Wasser verdünnte neutrale Reinigungsmittel ohne Wachse verwenden und dabei stets die Anleitungen auf der Packung befolgen.
- Bei häufigen Wäschen kann einfach nur sauberes Wasser verwendet werden.
- Keine säurehaltigen Produkte oder aggressiven Geräte verwenden, denn sie könnten die geläpften Materialien an der Oberfläche matt werden lassen und die zur Verfugung verwendeten Materialien auf Zementbasis angreifen.
- Es wird empfohlen, dem Hereintragen kratzfähiger Materialien von außen so gut wie möglich vorzubeugen: Quarz-sand und sonstige Materialien können auf der Oberfläche Abrieb verursachen und demzufolge den Glanz reduzieren.
- **HINTERLÜFTETE FASSADEN**  
Das Isoliermaterial hinter der Plattenwand funktioniert optimal, wenn es perfekt trocken ist; deshalb sollten heftige Wasserstrahle vermieden werden.

Es wird zur Verwendung eines neutralen Reinigers empfohlen (z.B: FILACLEANER - filasolutions.com).

**MERKE:** Auf Feinsteinzeugprodukten wird vom **Einsatz von Wachsen, ölhaltigen Seifen, Imprägniermitteln (wasser-ölabweisend) abgeraten.**

## FR Jointoiment et nettoyage après la pose

Avec les mortiers de jointoiment à prise normale, procéder au jointoiment du sol au bout de 24/48 heures; au bout de 4 heures, avec les mortiers de jointoiment à prise rapide.Pour les matériaux adoucis, il est recommandé d'utiliser des mortiers de jointoiment à base de ciment ton sur ton; sur de telles surfaces, ne pas utiliser de mortiers de jointoiment époxy ni de produits de jointoiment souples à base de matériaux synthétiques, encore moins s'il est d'une couleur contrastant avec celle du matériau. Ne pas ajouter d'additifs/latex au mortier de jointoiment, de tels produits rendant très difficile l'élimination des résidus par un nettoyage effectué à l'aide de simples détergents. Dans le cas où il serait décidé d'utiliser un mortier de jointoiment non conseillé, le tester sur le matériau pour en vérifier le résultat.

- Appliquer le mortier de jointoiment à la spatule caoutchoutée sur la surface à jointoyer en veillant à ne pas laisser d'espaces vides.
- Effectuer le jointoiment en procédant par petites portions de surface en éliminant au fur et à mesure les quantités excédantes à l'aide d'éponges ou de chiffons humides (avec eau propre uniquement) ou bien utiliser une machine prévue à cet effet en éliminant l'excès de produit alors que la fine couche de mortier est encore humide.

### Nettoyage après la pose

**La surface des produits Italgraniti résiste aux taches, est hygiénique et facile à entretenir; de telle sorte que ces caractéristiques soient préservées, il est indispensable d'effectuer un soigneux nettoyage aussitôt après la pose pour éliminer les résidus de ciment qui créent un film sur la surface du matériau qui tend à retenir davantage les saletés.**

L'élimination tardive ou mal effectuée des résidus de mortiers colles et mortiers de jointoiment peut laisser des auréoles difficiles à éliminer.

Aussi, le nettoyage initial doit être effectué aussitôt après la pose, à l'aide de produits à base acide, en frottant énergiquement et en procédant pour finir à un abondant rinçage à l'aide d'eau. De la sorte, il est possible d'éliminer les résidus de mortier de jointoiment, mortier colle, ciment, etc. Il est possible d'utiliser tout produit de nettoyage vendu dans le commerce, à l'exception des produits contenant de l'acide fluorhydrique (composés et dérivés) comme prévu par la norme EN 14411.

Il est conseillé d'utiliser un produit de nettoyage acide (ex: DETERDEK - filasolutions.com).

Pour éliminer des résidus de mortiers de jointoiment époxy, il est recommandé d'utiliser un détergent alcalin (ex: FILA CR10 - filasolutions.com).

**NB:** veiller à respecter scrupuleusement les instructions du fabricant figurant sur l'emballage du produit utilisé. Avant de procéder au nettoyage de la surface posée, il est recommandé de toujours tester le produit de nettoyage sur un échantillon de carreau non posé ou sur une zone limitée et peu visible.

### Protection après la pose

Pour protéger la surface céramique des saletés et du trafic de chantier, **il est recommandé de protéger le sol à l'aide de matériaux appropriés; cette précaution doit être considérée comme obligatoire dans le cas des carreaux à surface adoucie, davantage exposés aux risques de rayures et autres dommages.**

### Nettoyage courant

Pour le nettoyage courant, il suffit d'adopter quelques précautions simples, essentiellement dictées par le bon sens et par la connaissance des caractéristiques du matériau. Utiliser des détergents neutres, exempts de cires et dilués dans l'eau, en veillant à respecter les instructions figurant sur l'emballage.

- Pour les lavages fréquents, de l'eau propre peut suffire.
- Ne pas utiliser de produits acides ni d'ustensiles qui pourraient opacifier la surface des matériaux adoucis et qui pourraient endommager les produits de jointoiment à base de ciment.
- Il est recommandé de prévenir au maximum la présence de matériaux provenant de l'extérieur et pouvant provoquer des rayures, tels que le sable quartzifère et autres matériaux, qui peuvent induire une abrasion de la surface et, conséqeuement, une perte de brillant.

#### • FACIÈDES VENTILÉES

L'isolant placé derrière le bardage de dalles assure sa fonction de manière optimale s'il est parfaitement sec, aussi il est recommandé d'éviter les jets d'eau à haute pression.

Il est conseillé d'utiliser un détergent neutre (ex: FILACLEANER - filasolutions.com).

**NB:** sur les produits en grès cérame, **il est déconseillé d'utiliser des cires, des savons gras et des imprégnants (hydro et oléofuges).**



## Pulizia straordinaria / Extraordinary cleaning

**IT** Qualora il prodotto richieda un intervento di pulizia straordinaria per macchie particolarmente ostili, si consiglia di intervenire il prima possibile utilizzando detergenti specifici, indicati nella tabella seguente:

**EN** If the product requires extraordinary cleaning due to particularly stubborn stains, action should be taken as soon as possible, using the specific detergents recommended in the table below:

**DE** **Sonderreinigung.** Wenn das Produkt wegen besonders hartnäckiger Flecken einen Sonderreinigungseingriff verlangt, wird empfohlen, unter Verwendung der in der folgenden Tabelle gelisteten spezifischen Reinigungsmittel so schnell wie möglich zu handeln:

**FR** **Entretien exceptionnel.** Quand le revêtement nécessite une intervention de nettoyage exceptionnel pour éliminer des taches particulièrement tenaces, il est recommandé d'appliquer sans attendre un des détergents spécifiques indiqués dans le tableau ci-dessous:

**MACCHIA DA RIMUOVERE / STAIN FOR REMOVAL**  
ZU ENTFERNENDE FLECKEN  
TACHES À ENLEVER

**CATEGORIA DI DETERGENTE / TYPE OF DETERGENT**  
REINIGUNGSMITTEL-KATEGORIE  
CATÉGORIE DE DETERGENT

**DETERGENTI CONSIGLIATI / RECOMMENDED CLEANERS**  
EMPFOHLENE REINIGUNGSMITTEL  
DÉTERGENTS RECOMMANDÉS

<b>OLIO E GRASSO / OIL AND GREASE</b>	DETERGENTI ALCALINI / ALKALINE CLEANERS	FILAPS87				
<b>BIRRA / BEER</b>						
<b>CHEWING GUM / CHEWING GUM</b>						
<b>COLLA VINILICA / VINYL GLUE</b>						
<b>PNEUMATICO / TYRE MARKS</b>	SMACCHIATORI ALCALINI O SOLVENTI / ALKALINE STAIN-REMOVERS OR SOLVENTS	FILAZERO SIL				
<b>SILICONE / SILICONE</b>						
<b>SPUMA POLIURETANICA / POLYURETHANE FOAM</b>						
<b>RESIDUO DI NASTRO / ADHESIVE TAPE RESIDUES</b>						
<b>PASTELLO A CERA / WAX PASTEL MARKS</b>	DETERGENTI O SMACCHIATORI ALCALINI / ALKALINE STAIN-REMOVERS OR CLEANERS	FILAPS87 - FILASR95				
<b>INCHIOSTRO / INK</b>						
<b>NICOTINA / NICOTINE</b>						
<b>URINA E VOMITO / URINE AND VOMIT</b>						
<b>PENNARELLO / MARKER PEN STAINS</b>						
<b>TINTURA PER CAPELLI / HAIR DYE</b>						
<b>CAFFÈ / COFFEE</b>						
<b>VINO / WINE</b>						
<b>SANGUE / BLOOD</b>						
<b>COCA COLA / COCA COLA</b>						
<b>SEGNI DI VENTOSA / SUCTION-CUP MARKS</b>	DETERGENTI ALCALINI / ALKALINE CLEANERS	FILAPS87 - FILACRIO				
<b>RUGGINE / RUST</b>	DETERGENTI ACIDI O CONVERTITORI DI RUGGINE / ACID CLEANERS OR RUST CONVERTERS	DETERDEK - FILANO RUST				
<b>CEMENTO-SALNITRO / CEMENT-SALTPETRE</b>	DETERGENTI ACIDI O DISINCROSTANTI ACIDI / ACID CLEANERS OR ACID DESCALER	DETERDEK - FILAPH ZERO				
<b>CALCARE / LIMESCALE</b>						
<b>SEGNI DI ALLUMINIO - METALLO / ALUMINIUM - METAL MARKS</b>						
<b>MATITA / PENCIL</b>	DETERGENTI ALCALINI / ALKALINE CLEANERS	FILACRIO				
<b>STUCCO EPOSSIDICO / EPOXY FILLER</b>						
<b>VERNICE - PITTURE / VARNISH - PAINT</b>			SVERNICIANTI ALCALINI O SOLVENTI / ALKALINE PAINT STRIPPERS OR SOLVENTS	FILANO PAINT STAR		
<b>GRAFFITI / GRAFFITI</b>			PULITORI ALCALINI / ALKALINE CLEANERS	FUGANET		
<b>FUGA SPORCA / DIRTY GROUT LINES</b>						
<b>BITUME / BITUMEN</b>					SOLVENTI / SOLVENTS	FILASOLV
<b>CERA DI CANDELA / CANDLE WAX</b>					DETERGENTI NEUTRI / NEUTRAL CLEANERS	FILACLEANER
<b>MANUTENZIONE ORDINARIA / ROUTINE MAINTENANCE</b>						
<b>CERA ANTIGRAFFIO / SCRATCH REMOVER WAX</b>						



**IT NB:** In caso di prodotti lappati evitare di utilizzare i detergenti acidi FILA DETERDEK in concentrazioni elevate. Si consiglia di diluirli in acqua al 10-15%. Prima di qualsiasi impiego dei prodotti detergenti, è importante fare sempre una prova su una porzione di superficie, in particolare per quanto riguarda i prodotti lappati. Si consiglia di diluire con acqua tutti i prodotti detergenti.

**EN NB:** On polished products, do not use FILA DETERDEK acid cleaners at high concentrations. They should be diluted in water to 10-15%. Before any use of cleaners, it is important always to test them on part of the surface, especially on polished products. All cleaning products should be diluted with water.

**DE MERKE:** Bei anpolierten Produkten ist die Verwendung der säurehaltigen Reinigungsmittel FILA DETERDEK in hohen Konzentrationen zu vermeiden. Es wird zu einer 10-15%-igen Verdünnung in Wasser empfohlen. Vor jedem Gebrauch der Reinigungsprodukte ist unbedingt stets auf einer Oberflächenportion eine Probreinigung durchzuführen, besonders bei anpolierten Produkten und Dekoren. Es wird empfohlen, alle Reinigungsprodukte mit Wasser zu verdünnen.













**FR NB:** Dans le cas des produits à finition adoucie, éviter d'utiliser les détergents acides FILA DETERDEK à une concentration élevée. Il est recommandé de les diluer dans l'eau à 10-15%. Avant toute application de produits détergents, il est important d'effectuer un essai sur une partie de la surface, en particulier pour les matériaux à finition adoucie et les décors. Il est recommandé de diluer dans l'eau tous les détergents.

## Tabella calibri / Working size chart

FORMATO / SIZE	6 mm	12 mm	9 mm	20 mm OPEN
 120x280 cm 47 <sup>1/4</sup> x 110 <sup>1/4</sup>	1195x2797 mm			
 160x320 cm 62 <sup>3/8</sup> x 125 <sup>3/4</sup>		1620x3240 mm		
 120x120 cm 47 <sup>1/4</sup> x 47 <sup>1/4</sup>			1195x1195 mm	
 80x160 cm 31 <sup>1/2</sup> x 63"			797x1596 mm	
 80x80 cm 31 <sup>1/2</sup> x 31 <sup>1/2</sup> "			797x797 mm	
 60x120 cm 23 <sup>1/2</sup> x 47 <sup>1/4</sup> "			596,5x1195 mm	596,5x1195 mm
 20x120 cm 8" x 47 <sup>1/4</sup> "			197,5x1195 mm	
 60x60 cm 23 <sup>1/2</sup> x 23 <sup>1/2</sup> "			596,5x596,5 mm	596,5x596,5 mm
 30x60 cm 11 <sup>7/8</sup> x 23 <sup>1/2</sup> "			297,2x596,5 mm	
 15x60 cm 6" x 23 <sup>1/2</sup> "			147,6x596,5 mm	
 9x50 cm 3 <sup>1/2</sup> x 19 <sup>3/4</sup> "			90x495,4 90x585,4 mm	
 10x30 cm 4" x 11 <sup>7/8</sup> "			97,7x297,2 mm	















# Tabella tecniche gres porcellanato / Technical specifications porcelain stoneware

CONFORME A NORME / CONFORMING TO STANDARDS / GEMÄSS DEN NORMEN / CONFORMES AUX NORMES  
EN 14411 ISO 13006 APPENDICE G GRUPPO Bia UGL CON Ev ≤ 0,5%

CARATTERISTICA TECNICA PHYSICAL PROPERTIES TECHNISCHE DATEN CARACTERISTIQUE TECHNIQUE	METODICA DI PROVA TESTING METHOD PRÜFVERFAHREN NORME D'ESSAIS	RIFERIMENTO NORMA REFERENCE STANDARD STANDARDWERT RÉFÉRENCE NORME	VALORE PRODOTTO PRODUCT VALUES- PRODUKT WERTE VALEUR PRODUIT
		7cm ≤ N < 15 cm (mm)	N ≥ 15 cm (%) (mm)
		Lunghezza e larghezza - Length and width - Länge und Breite Longueur et largeur	±0.9 ±0.6 ±2.0
		Spessore - Thickness - Stärke - Epaisseur	±0.5 ±5.0 ±0.5
		Rettilineità spigoli - Linearity - Kantengeradheit - Rectitude des arêtes	±0.75 ±0.5 ±1.5
 Dimensioni Sizes Abmessungen Dimensions	EN ISO 10545-2	Ortogonalità - Wedging - Rechtwinkligkeit - Orthogonalité	±0.75 ±0.5 ±2.0
		Planarità - Warpage - Ebenförmigkeit - Planéité	±0.75 ±0.5 ±2.0
		Aspetto: percentuale di piastrelle accettabili nel lotto - appearance: percentage of acceptable tiles, per lot - oberflächenbeschaffenheit: prozentsatz der fliesen, die den geforderten eigenschaften entsprechen - aspect: pourcentage de carreaux acceptables sur la fourniture totale	95 % min. 95 % min.
 Assorbimento d'acqua % - Water absorption % Wasseraufnahme % - Absorption d'eau %	EN ISO 10545-3	Ev ≤ 0,5%	Conforme - Conforming Erfüllt - Conforme
 Resistenza alla flessione - Modulus of rupture Biegezugfestigkeit - Résistance à la flexion	EN ISO 10545-4	Valore medio 35 N/mm <sup>2</sup> min.	Conforme - Conforming Erfüllt - Conforme
 Sforzo di rottura - Breakage resistance Bruchlast - Resistance à la rupture		sp. > = 75 mm: min 1300 N sp. < 75 mm: min 700 N	Conforme - Conforming Erfüllt - Conforme
 Resistenza all'abrasione profonda - Deep abrasion resistance - Bestimmung des Widerstandes gegen tiefen Verschleib - Résistance à l'abrasion	EN ISO 10545-6	175 mm <sup>3</sup> max.	Medio - Average - Mittelwert Moyenne
 Coefficiente di dilatazione termica lineare - Thermal expansion coefficient - Wärmeausdehnung - Coefficient de dilatation thermique linéaire	EN ISO 10545-8	Valore dichiarato - Declared value - Valeur déclaré Valor declarado	6,8 MK-1
 Resistenza agli sbalzi termici - Thermal shock resistance - Temperaturwechselbeständigkeit - Résistance aux écarts de température	EN ISO 10545-9	Test superato in accordo con iso 10545-1 - Pass according to iso 10545-1 Test ueberstanden nach ISO 10545-1 - Pv en accord avec norme en 10545-1	* Resistente - Resistant Widerstandsfähig - Résistants
 Resistenza al gelo - Frost resistance Frostbeständigkeit - Résistance au gel	EN ISO 10545-12	Test superato in accordo con iso 10545-1 - Pass according to iso 10545-1 Test ueberstanden nach ISO 10545-1 - Pv en accord avec norme en 10545-1	* Resistente - Resistant Widerstandsfähig - Résistants
 Resistenza a basse concentrazioni di acidi e alcali - Resistance to low concentrations of acids and alkali - Beständigkeit gegen schwach konzentrierte säuren und laugen - Résistance à des basses concentrations d'acides et bases	EN ISO 10545-13	Valore dichiarato - Declared value - Angegebener Wert - Valeur déclaré	* Resistente - Resistant Widerstandsfähig - Résistants
 Resistenza ad alte concentrazioni di acidi e alcali - Resistance to high concentrations of acids and alkali - Beständigkeit gegen stark konzentrierte säuren und laugen - Résistance à des hautes concentrations d'acides et bases		Valore dichiarato - Declared value - Angegebener Wert - Valeur déclaré	* Resistente - Resistant Widerstandsfähig - Résistants
 Resistenza ai prodotti chimici di uso domestico e agli additivi per piscina - Resistance to domestic chemicals and additives for swimming pools - Beständigkeit gegen chemische haushaltsreiniger und zusatzstoffe für schwimmbäder - Résistance aux prod. chimiques d'usage domestique et additifs pour piscines		UB min.	UA
 Resistenza alle macchie di piastrelle non smaltate naturali - Stain resistance of unglazed matte porce- lain - Fleckenbeständigkeit von unglasierten natur Fliesen - Résistance aux taches des carreaux non émaillés naturel	EN ISO 10545-14	Valore dichiarato - Declared value - Angegebener Wert - Valeur déclaré	* Resistente - Resistant Widerstandsfähig - Résistants
 Resistenza alla scivolosità Slip resistance Rutschfestigkeit Résistance au dérapage	EN 16165	Annex A	Valore disponibile a richiesta Value available upon request Wert auf Anfrage verfügbar Valeur disponible sur demande
		Annex B	Valore disponibile a richiesta Value available upon request Wert auf Anfrage verfügbar Valeur disponible sur demande
		B.C.R.A. - D.M.236/ 89	> 0,40 Dry / > 0,40 Wet
		ANSI A326.3 D CDF	≥ 0,42 Wet

\* Si raccomanda di consultare Project Department per le indicazioni necessarie al corretto utilizzo.  
It's advisable to refer Project Department for all necessary guidelines to a correct use.  
Zur korrekten Anwendung wird empfohlen unsere Project Department zu kontaktieren.  
Merci de consulter notre Project Department pour les indications a un usage correct.

CONFORME A NORME / CONFORMING TO STANDARDS / GEMÄSS DEN NORMEN / CONFORMES AUX NORMES  
EN 14411 ISO 13006 APPENDICE G GRUPPO Bia GL CON Ev ≤ 0,5%

CARATTERISTICA TECNICA PHYSICAL PROPERTIES TECHNISCHE DATEN CARACTERISTIQUE TECHNIQUE	METODICA DI PROVA TESTING METHOD PRÜFVERFAHREN NORME D'ESSAIS	RIFERIMENTO NORMA REFERENCE STANDARD RÉFÉRENCE NORME STANDARDWERT	VALORE PRODOTTO PRODUCT VALUES- PRODUKT WERTE VALEUR PRODUIT
		7cm ≤ N < 15 cm (mm)	N ≥ 15 cm (%) (mm)
		Lunghezza e larghezza - Length and width - Länge und Breite Longueur et largeur	±0.9 ±0.6 ±2.0
		Spessore - Thickness - Stärke - Epaisseur	±0.5 ±5.0 ±0.5
		Rettilineità spigoli - Linearity - Kantengeradheit Rectitude des arêtes	±0.75 ±0.5 ±1.5
 Dimensioni Sizes Abmessungen Dimensions	EN ISO 10545-2	Ortogonalità - Wedging - Rechtwinkligkeit - Orthogonalité	±0.75 ±0.5 ±2.0
		Planarità - Warpage - Ebenförmigkeit - Planéité	±0.75 ±0.5 ±2.0
		Aspetto: percentuale di piastrelle accettabili nel lotto - appearance: percentage of acceptable tiles, per lot - oberflächenbeschaffenheit: prozentsatz der fliesen, die den geforderten eigenschaften entsprechen - aspect: pourcentage de carreaux acceptables sur la fourniture totale	95 % min. 95 % min.
 Assorbimento d'acqua % - Water absorption % Wasseraufnahme % - Absorption d'eau %	EN ISO 10545-3	Ev ≤ 0,5%	Conforme - Conforming Erfüllt - Conforme
 Resistenza alla flessione - Modulus of rupture Biegezugfestigkeit - Résistance à la flexion	EN ISO 10545-4	Min 35 N/mm <sup>2</sup>	Conforme - Conforming Erfüllt - Conforme
 Sforzo di rottura - Breakage resistance Bruchlast - Resistance à la rupture		sp. > = 75 mm: min 1300 N sp. < 75 mm: min 700 N	Conforme - Conforming Erfüllt - Conforme
 Resistenza all'abrasione - Abrasion resistance Widerstand gegen Verschleiss - Résistance à l'abrasion	EN ISO 10545-7	Richiesta - Required - Gefordert - Requite	Vedi il minimale - See single tile picture Siehe einzelnen abbildungen - Voir sous du carreau photo
 Coefficiente di dilatazione termica lineare Thermal expansion coefficient - Wärmeausdehnung - Coefficient de dilatation thermique linéaire	EN ISO 10545-8	* Metodica di prova disponibile - Testing method available Prüfverfahren greifbar - Norme d'essais	6,8 MK*
 Resistenza agli sbalzi termici - Thermal shock resistance - Temperaturwechselbeständigkeit - Résistance aux écarts de température	EN ISO 10545-9	* Metodica di prova disponibile - Testing method available Prüfverfahren greifbar - Norme d'essais	* Resistente - Resistant Widerstandsfähig - Résistants
 Determinazione della resistenza al cavillo Glaze crazing resistance - Widerstand gegen Haarriß von der Glasur - Résistance aux taches	EN ISO 10545-11	Richiesta - Required - Gefordert - Requite	* Resistente - Resistant Widerstandsfähig - Résistants
 Resistenza al gelo - Frost resistance Frostbeständigkeit - Résistance au gel	EN ISO 10545-12	Richiesta - Required - Gefordert - Requite	* Resistente - Resistant Widerstandsfähig - Résistants
 Resistenza a basse concentrazioni di acidi e alcali Resistance to low concentrations of acids and alkali - Beständigkeit gegen schwach konzentrierte säuren und laugen - Résistance à des basses concentrations d'acides et bases		Come dichiarato dal produttore - See manufacturer's declaration Selon déclaration du producteur - Entsprechend der herstellerangaben	* Resistente - Resistant Widerstandsfähig - Résistants
 Resistenza ad alte concentrazioni di acidi e alcali Resistance to high concentrations of acids and alkali - Beständigkeit gegen schwach konzentrierte säuren und laugen - Résistance à des basses concentrations d'acides et bases	EN ISO 10545-13	* Metodica di prova disponibile - Testing method available Prüfverfahren greifbar - Norme d'essais	* Resistente - Resistant Widerstandsfähig - Résistants
 Resistenza ai prodotti chimici di uso domestico e agli additivi per piscina - Resistance to domestic chemicals and additives for swimming pools - Beständigkeit gegen chemische haushaltsreiniger und zusatzstoffe für schwimmbäder - Résistance aux prod. chimiques d'usage domestique et additifs pour piscines		GB min.	Conforme - Conforming Erfüllt - Conforme
 Resistenza alle macchie di piastrelle non smaltate naturali - Stain resistance of unglazed matte porce- lain - Fleckenbeständigkeit von unglasierten natur Fliesen - Résistance aux taches des carreaux non émaillés naturel	EN ISO 10545-14	Valore dichiarato - Declared value - Angegebener Wert - Valeur déclaré	* Resistente - Resistant Widerstandsfähig - Résistants
 Resistenza alla scivolosità Slip resistance Rutschfestigkeit Résistance au dérapage	B.C.R.A. - D.M.236/ 89	Dove richiesto - If needed - Nach anforderung - Si demande	Valore disponibile a richiesta Value available upon request Wert auf Anfrage verfügbar Valeur disponible sur demande

## Simbologia / Symbol captions

### Spessori gres porcellanato / Porcelain Stoneware Thickness

— 6 mm    — 9 mm    — 12 mm    — 20 mm

### Fascia prezzo / Price band

■ Fascia prezzo al mq.  
Price band per m<sup>2</sup>  
Preisgruppe/ m<sup>2</sup>  
Fourchette de prix/m<sup>2</sup>

■ Fascia prezzo al pezzo  
Price band per piece  
Preisgruppe / Stück  
Fourchette de prix/pièce

### Traffico / Traffic



MEDIUM TRAFFIC

#### TRAFFICO MEDIO

Gres porcellanato ideale per aree residenziali e commerciali leggere soggette ad usura causata da un livello di calpestio medio come: ristoranti, uffici, negozi, hotel, business lounge, ecc. Sono esclusi passaggi obbligati ed aree adiacenti ad uscite esterne.

#### MEDIUM TRAFFIC

Porcelain stoneware is ideal for residential and light-duty commercial areas subject to wear from medium-level foot traffic, such as restaurants, offices, shops, hotels, business lounges etc. Not suitable for passageways and areas near entrances/exits.

#### MITTLERE BELASTUNG

Ideales Feinsteinzeug für leicht belastete Wohn- und Gewerbebereiche, die der Abnutzung durch eine mittlere Begehungsfrequenz ausgesetzt sind, z.B.: Restaurants, Büros, Geschäfte, Hotels, Business-Lounges, usw. Ausgeschlossen sind Pflichtpassagen und Bereiche neben externen Ausgängen.

#### TRAFIC MOYEN

Grès cérame idéal pour les espaces résidentiels et commerciaux légers sujets à usure causée par un niveau de trafic moyen, tels que: restaurants, bureaux, magasins, hôtels, business lounge, etc. Sont exclues les voies de passage obligé et les zones jouxtant les sorties donnant sur l'extérieur.



HEAVY TRAFFIC

#### TRAFFICO PESANTE

Gres porcellanato ideale per tutte le destinazioni d'uso, incluse le aree pubbliche e commerciali soggette ad usura causata da un livello di calpestio elevato come: aeroporti, centri commerciali, luoghi di culto, scuole, musei, ospedali, ecc.

#### HEAVY TRAFFIC

Porcelain stoneware is ideal for all intended uses, including public and commercial areas subject to wear from intensive foot traffic such as airports, shopping malls, places of worship, schools, museums, hospitals etc.

#### HOHE BELASTUNG

Ideales Feinsteinzeug für alle Bestimmungszwecke, einschließlich öffentliche und gewerbliche Bereiche, die der Abnutzung durch eine starke Begehungsfrequenz ausgesetzt sind, z.B.: Flughäfen, Einkaufszentren, Kultstätten, Schulen, Museen, Krankenhäuser, usw.

#### TRAFIC INTENSE

Grès cérame idéal pour tous usages, y compris les espaces publics et commerciaux sujets à usure causée par un niveau de trafic intense, tels que: aéroports, centres commerciaux, lieux de culte, établissements scolaires, musées, hôpitaux, etc

### Unità di brillantezza / Gloss unit



GLOSS UNITS

#### UNITÀ DI BRILLANTEZZA:

I valori vengono espressi in unità di brillantezza (GU gloss unit) e si riferiscono a una scala di brillantezza che varia da 0 (per la superficie molto opaca) a 100 (per la superficie molto lucida). Nel nostro caso specifico:

Valori > 80 = Superficie molto brillante ----- 30 < Valori > 60 = Superficie semilucida

#### GLANZEINHEIT:

Die Werte sind in Glanzeinheiten (GU gloss unit) ausgedrückt und beziehen sich auf eine Glanzskala, die von 0 (für sehr matte Oberflächen) bis 100 (für stark glänzende Oberflächen) reicht. In unserem spezifischen Fall:

Werte > 80 = Sehr glänzende Oberfläche ----- 30 < Werte > 60 = Halbglanz-Oberfläche

#### GLOSS UNIT:

Values are in gloss units (GU) and refer to a gloss scale running from 0 (for very matte surfaces) to 100 (for very glossy surfaces). In our specific case:

Values > 80 = Very glossy surface ----- 30 < Values > 60 = Semigloss surface

#### UNITÉ DE BRILLANCE :

Les valeurs sont exprimées en unité de brillance (GU gloss unit) et se réfèrent à une échelle de brillance qui varie de 0 (pour la surface la plus opaque) à 100 (pour la surface très brillante). Dans le cas des présents produits :

Valeurs > 80 = Surface très brillante ----- 30 < Valeurs > 60 = Surface semi-brillante

### Mix di superfici / Mix surfaces



MIX SURFACES

Mix di superfici già miscelate all'interno delle scatole, più facili da ordinare e pronte all'uso.

Every box contains 1 piece in every available finish, to make it easier and ready to start tiling.

Gemischten Oberflächen zusammen verpackt. Einfach zu bestellen und zu verlegen.

Surfaces mélangées à l'intérieur de la boîte, facile à commander et prêtes à l'emploi.

### Variazioni di stonalizzazione / Shade variation guideline



V1 LOW

ASPETTO UNIFORME  
UNIFORM APPEARANCE  
Einheitliches Aussehen  
Aspect uniforme



V2 MODERATE

LIEVE VARIAZIONE  
LIGHT VARIATION  
Geringe abweichung  
Légère variation



V3 HIGH

ALTA VARIAZIONE  
HIGH VARIATION  
HOHE abweichung  
Variation haute



V4 SUBSTANTIAL

FORTE STONALIZZAZIONE  
SUBSTANTIAL VARIATION  
Akzentuierte abweichung  
Effet dénuancé tres accentué



I Travertini Bianco Vein Cut 60x120 20mm, I Cementi Bianco 120x280x0,6

## Condizioni generali di vendita / General conditions of sale

Condizioni generali di vendita

Condizioni generali di vendita

### IT Condizioni generali di vendita

#### 1. Normativa contrattuale

Le presenti condizioni generali, salve eventuali modifiche o deroghe concordate per iscritto, disciplinano tutti i contratti di vendita, relativi ai prodotti commercializzati da ITALGRANITI GROUP, conclusi fra ITALGRANITI GROUP e l'acquirente. Le variazioni delle condizioni generali di vendita, le transazioni e gli abbuoni, anche se effettuati su iniziativa di nostri agenti, procacciatori o altri intermediari, saranno impegnative per ITALGRANITI GROUP solo dopo eventuale conferma scritta e comunque limitatamente al singolo contratto cui si riferiscono.

#### 2. Proposta d'ordine

Le offerte effettuate all'acquirente da agenti, procacciatori o altri intermediari e le proposte d'ordine da essi inoltrate a ITALGRANITI GROUP non saranno vincolanti per ITALGRANITI GROUP fino a quando l'ordine dell'acquirente non sia stato accettato per iscritto.

#### 3. Conferma d'ordine

Il contratto di vendita si perfezionerà con il ricevimento da parte dell'acquirente di una conferma d'ordine di ITALGRANITI GROUP oppure con il ricevimento da parte dell'acquirente o del vettore da lui prescelto dell'ordine di carico della merce.

L'eventuale conferma d'ordine di ITALGRANITI GROUP che sia, anche parzialmente, difforme dalla proposta d'ordine, sarà vincolante per l'acquirente che non l'abbia contestata per iscritto entro dieci giorni dal ricevimento della conferma d'ordine.

#### 4. Consegna

La consegna si intende sempre eseguita ad ogni effetto nei magazzini di ITALGRANITI GROUP al momento della consegna della merce al vettore.

Pertanto la merce viaggia sempre a rischio e pericolo dell'acquirente e ogni responsabilità di ITALGRANITI GROUP cessa con la consegna al vettore. Eventuali reclami relativi a danni subiti dalla merce durante il trasporto dovranno pertanto essere inviati esclusivamente al vettore.

Il vettore incaricato dal destinatario delle merci si impegna a consegnare la merce al destinatario nel luogo indicato nel documento di trasporto. Egli comunicherà altresì a ITALGRANITI GROUP la mancata consegna della merce e/o l'avvenuta consegna della stessa presso luogo di destinazione diverso da quello comunicato a ITALGRANITI GROUP dal cessionario e indicato nel documento di trasporto e, entro e non oltre 30 giorni dalla consegna, mediante invio, tramite posta oppure email oppure fax, di copia del documento di trasporto completo della propria sottoscrizione e dai dati identificativi del destinatario delle merci presso il quale è stata effettuata la consegna.

#### 5. Termine di consegna

Il termine di consegna, decorre dal giorno della conclusione del contratto e, salvo espresso accordo scritto, deve considerarsi puramente indicativo e non essenziale. Se il termine di consegna è espresso in giorni, si intende riferito a giorni lavorativi in base al calendario italiano. Ogni causa di forza maggiore sospende la decorrenza del termine per tutta la durata della causa stessa. E' esclusa ogni responsabilità di ITALGRANITI GROUP per danni derivanti da ritardo o mancata consegna (totale o parziale), salvi i casi di dolo o colpa grave.

#### 6. Pagamento

Il luogo del pagamento è fissato presso la nostra sede amministrativa, anche nel caso di emissione di tratte o ricevute bancarie, ovvero di rilascio di effetti cambiari; eventuali deroghe saranno valide solo se da noi concesse per iscritto. Qualsiasi ritardo nel pagamento dà a ITALGRANITI GROUP il diritto di risolvere i contratti in corso o di sospendere le consegne della merce o di pretendere il pagamento anticipato, anche con riferimento ad altri contratti, nonché il diritto al recupero delle spese e al risarcimento degli eventuali danni subiti, senza alcun diritto per l'acquirente ad avanzare pretese, indennizzi od altro. Inoltre, qualsiasi ritardo nel pagamento, darà luogo all'immediata decorrenza degli interessi di mora in misura pari al tasso ufficiale di riferimento aumentato di cinque punti, senza bisogno di preventiva messa in mora.

#### 7. Restituzione dei pagamenti non dovuti

L'acquirente non potrà sospendere o ritardare il pagamento per alcun motivo, compresi pretesi vizi o non conformità dei prodotti, fatta salva comunque la facoltà di ottenere la restituzione di quanto pagato indebitamente.

#### 8. Riserva di proprietà

Nel caso in cui il pagamento, per accordi contrattuali, debba essere effettuato in tutto o in parte dopo la consegna, i prodotti consegnati restano di proprietà di ITALGRANITI GROUP fino all'integrale pagamento del prezzo.

#### 9. Garanzia

I prodotti di ITALGRANITI GROUP sono garantiti conformi alle norme UNI-EN in vigore. Le indicazioni di pesi, misure, dimensioni, colore, tonalità ed altri dati contenuti in tutto il materiale pubblicitario e di promozione hanno carattere meramente indicativo e non sono vincolanti. La garanzia di ITALGRANITI GROUP è in ogni caso limitata ai prodotti di prima scelta con una percentuale di piastrelle difettose non superiore al 5% (cinque per cento); la garanzia è espressamente esclusa per i prodotti di scelta occasionale, secondaria, di sottoscelta e di stock. Le differenze di tonalità non potranno in alcun caso essere considerate un vizio o una difformità del prodotto.

La garanzia ha una durata limitata a due anni dalla data di consegna.

#### 10. Reclami

I vizi e i difetti riconoscibili devono essere denunciati a pena di decadenza entro otto giorni dalla consegna; i vizi e i difetti occulti dovranno essere denunciati a pena di decadenza entro otto giorni dalla scoperta. Il reclamo dovrà essere inviato ad ITALGRANITI GROUP per iscritto e dovrà sempre essere effettuato prima della posa in opera. L'acquirente si impegna a tenere a disposizione il materiale contestato per poter consentire la verifica dei difetti. In ogni caso ITALGRANITI GROUP, salve le ipotesi di dolo o colpa grave, non sarà tenuta ad alcun risarcimento danno, esclusa l'eventuale sostituzione del prodotto.

#### 11. Diritto applicabile e foro competente

I contratti sono regolati ed interpretati in conformità al diritto italiano.

Il Foro competente sarà quello di Modena (Italia).

Condizioni generali di vendita

### EN General conditions of sale

#### 1. Contract Validity

Subject to amendments or waivers agreed in writing, these general conditions shall govern all sales contracts concerning the products distributed by ITALGRANITI GROUP agreed between ITALGRANITI GROUP and the purchaser. Any modifications to the general conditions of sale, transactions and allowances, even if made on the initiative of our agents, brokers or other intermediaries, shall only be binding on ITALGRANITI GROUP after any written confirmation, and only with regard to the single contract to which they refer.

#### 2. Order Proposals

Offers made to the purchaser by agents, brokers or other intermediaries and the order proposals they send to ITALGRANITI GROUP shall not be binding on ITALGRANITI GROUP until the purchaser's order has been accepted in writing.

#### 3. Order Confirmation

The sales contract shall become definitive on receipt by the purchaser of an ITALGRANITI GROUP order confirmation, or receipt by the purchaser or its chosen carrier of the order to load the goods.

Any ITALGRANITI GROUP order confirmation which differs even in part from the order proposal shall be binding on the purchaser unless the latter has disputed it in writing within ten days after receipt of the order confirmation.

#### 4. Delivery

Delivery shall always be considered to have taken place at the ITALGRANITI GROUP stores on consignment of the goods to the carrier.

Therefore the goods shall always travel at the purchaser's risk, and all responsibility on the part of ITALGRANITI GROUP shall cease on consignment to the carrier. Any claims for damage incurred by the goods in transit shall therefore be made solely against the carrier.

With reference to sales made for delivery in EU countries, the recipient of the goods agrees to inform ITALGRANITI GROUP in writing about any failure to deliver the goods to the destination specified on the transport document, or about their delivery to a location different to that specified on the transport document, within a period of thirty days subsequent to the expected delivery date, by sending a suitable declaration and a copy of the signed transport document to the latter by post, fax, e-mail or any other means. Subsequent to the receipt of the above documentation, ITALGRANITI GROUP will amend the invoices issued with the application of VAT pursuant to Presidential Decree no. 600/1973.

It is understood that the recipient of the goods agrees to hold ITALGRANITI GROUP free from all taxes, surtaxes, interest and penalties of any kind, as well as from all related legal expenses, if the latter receives charges from the tax authorities as a consequence of any failure to make the above written communication. The recipient of the goods, taking note of the communication that ITALGRANITI GROUP will ask the carrier to sign, also agrees to inform the carrier about all changes or modifications to the destination of the goods. Breach of this obligation will result in ITALGRANITI GROUP recharging to the recipient of the goods all taxes, surtaxes, interest and penalties of any kind, as well as all related legal expenses, deriving from assessments made by the tax authorities as a consequence of failure to make the above communication.

#### 5. Delivery Terms

The cout of the delivery term shall start from the day of finalisation of the contract, and the term shall be considered purely guideline and non-binding unless otherwise agreed in writing. Delivery terms in days shall refer to working days in the Italian calendar. All situations of force majeure shall suspend the count of the delivery time for the entire duration of the situation concerned. ITALGRANITI GROUP shall not be liable for any damage deriving from late delivery or total or partial failure to deliver, except in cases of malicious intent or serious fault.

#### 6. Payment

The place of payment shall be our head accounts department, even in the event of issue of drafts or bank payment orders, or the issue of bills of exchange; any waivers shall only be valid if granted in writing. Any delay in payment shall entitle ITALGRANITI GROUP to terminate the current contracts, suspend delivery of the goods or demand payment in advance, even with reference to other contracts, and to recoup the expenses and compensation for any damages incurred, without any right on the part of the purchaser to claim compensation or damages. Moreover, any delay in payment shall immediately trigger the charging of interest at the official discount rate increased by five percent, with no need for prior formal intimation to pay.

#### 7. Return of Payments not Due

The purchaser shall not be permitted to suspend or delay payment for any reason, including claimed defects or nonconformity of the products, subject to the right to return of any amounts paid unduly.

#### 8. Retention of Ownership

In the event that, by contract, all or part of the payment is to be made after delivery, the products delivered shall continue to be the property of ITALGRANITI GROUP until full payment of the price.

#### 9. Warranty

ITALGRANITI GROUP products are guaranteed compliant with the relevant UNI-EN standards. All references to weights, measurements, dimensions, colours, shades and other data in all advertising and promotional material shall be merely guideline and not binding. In all events, the ITALGRANITI GROUP warranty shall be limited to first grade products with a percentage of defective tiles not exceeding 5% (five per cent); no warranty shall be provided for random-selected, second grade, substandard or stock tiles. Under no circumstances shall variations in shade be considered a fault or nonconformity of the product. The duration of the warranty shall be limited to two years from the delivery date.

#### 10. Claims

Recognisable faults and defects shall be reported within eight days after delivery, concealed faults and defects shall be reported within eight days after discovery; in both cases, failure to comply with the above term shall lead to forfeiture of rights. The claim shall be sent to ITALGRANITI GROUP in writing and shall always be made before installation of the material. The purchaser undertakes to keep the material to which the claim relates at the vendor's disposal to allow inspection of the defects. In all events, except in case of malicious intent or serious fault, ITALGRANITI GROUP shall not be obliged to provide any form of compensation except for replacement of the product, if appropriate.

#### 11. Applicable law and legal jurisdiction

Contracts shall be governed and interpreted in accordance with Italian law. The Modena (Italy) law court shall have jurisdiction.

Condizioni generali di vendita

### DE Allgemeine Verkaufsbedingungen

#### 1. Vertragsbestimmungen

Die vorliegenden allgemeinen Bedingungen regeln, vorbehaltlich schriftlich vereinbarter Änderungen oder Abweichungen, alle zwischen ITALGRANITI GROUP und dem Käufer abgeschlossenen Kaufverträge für die von ITALGRANITI GROUP vertriebenen Produkte.Von den Allgemeinen Verkaufsbedingungen abweichende Bedingungen, Geschäftsabschlüsse und Rabatte werden, auch wenn diese durch unsere Handelsvertreter, Akquisiteure oder sonstige Geschäftsvertremlter zustande kommen, für ITALGRANITI GROUP erst nach einer schriftlicher Anerkennung verbindlich und beziehen sich lediglich auf den einzelnen Vertrag.

#### 2. Auftrag

Die dem Käufer von Handelsvertretern, Akquisiteuren oder anderen Geschäftsvermittlern gemachten Angebote und die von diesen an ITALGRANITI GROUP weitergeleiteten Aufträge sind für ITALGRANITI GROUP erst nach schriftlicher Annahme verbindlich.

#### 3. Auftragsbestätigung

Der Kaufvertrag gilt als abgeschlossen, sobald der Käufer die Auftragsbestätigung seitens ITALGRANITI GROUP erhält bzw. sobald der Käufer oder der von ihm bestellte Transportführen den Auftrag zur Warenladung erhält. Auftragsbestätigungen von ITALGRANITI GROUP, die auch teilweise vom Auftrag abweichen, sind für den Käufer verbindlich, sofern er sie nicht innerhalb von zehn Tagen nach Erhalt beanstandet.

#### 4. Lieferung

Als Leistungsort für die Lieferung gelten stets die Lager von ITALGRANITI GROUP. Mit Übernahme der Ware durch den Transportführer gilt die Lieferung als vollzogen.

Die Ware ist deshalb stets auf Risiko und Gefahr des Käufers unterwegs, da mit ihrer Übergabe an den Transportführer jegliche Haftung für ITALGRANITI GROUP erlischt. Reklamationen bei Transportschäden sind beim Transportführer vorzubringen. Bezüglich der die in die EU-Länder bestimmten Verkäufe verpflichtet sich der Warenempfänger, ITALGRANITI GROUP die ausgebliebene Zustellung der Ware an dem im Warenbegleitschein vermerkten Empfangsort bzw. die erfolgte Zustellung derselben Ware an einem anderen als dem im Warenbegleitschein vermerkten Ort spätestens dreißig Tage nach festgesetztem Zustellungsdatum durch Einsenden einer zweckentsprechenden Erklärung und einer Kopie des unterzeichneten Warenbegleitscheins auf dem Postweg oder per Telefax, E-Mail oder mit beliebigen anderen Kommunikationsmitteln schriftlich mitzuteilen. Nach Eingang vorgenannter Unterlagen veranlasst ITALGRANITI GROUP die Regelung der ausgestellten Rechnungen durch Anwendung der Mehrwertsteuer laut Dekret des Präsidenten der Republik Nr. 600/1973. Es bleibt dabei, dass sich der Warenempfänger verpflichtet, ITALGRANITI GROUP schadlos zu halten an Steuern, Zuschlägen, Zinsen und Strafen jeder Art, sowie an Rechtsunkosten, sollte ihm die Finanzverwaltung Zahlungspflichten aufgrund des Versäumnisses besagter schriftlicher Mitteilung zur Last legen. Nach Kenntnismahme der Mitteilung, zu deren Unterzeichnung ITALGRANITI GROUP den Frachtführer bitten wird, verpflichtet sich der Warenempfänger außerdem, dem Frachtführer selbst jede Verlegung oder Änderung des Warenempfangsorts mitzuteilen. Das Versäumnis besagter Pflicht bewirkt, dass ITALGRANITI GROUP dem Warenempfänger etwaige Steuern, Zuschläge, Zinsen und Strafen jeder Art sowie Rechtsunkosten im Falle von Beanstandungen seitens der Finanzverwaltung infolge besagter versäumter Mitteilung zur Last legt.

#### 5. Lieferfrist

Sofern keine ausdrückliche Vereinbarung in schriftlicher Form vorliegt, beginnen die Lieferfristen ab dem Tag des Vertragsabschlusses und sind als nicht streng verbindlich anzusehen. Falls die Lieferfristen in Anzahl von Tagen ausgedrückt sind, beziehen sich diese auf Werktage nach italienischem Kalender. Bei Ereignissen höherer Gewalt verschiebt sich der Fristbeginn um die Dauer des Ereignisses. ITALGRANITI GROUP übernimmt keinerlei Haftung für durch Lieferverzug oder Nichtlieferung (Gesamt- oder Teillieferung) entstandene Schäden, außer in den Fällen von Vorsatz oder grober Fahrlässigkeit.

#### 6. Zahlung

Erfüllungsort für die Zahlung ist unser Geschäftssitz, auch bei Ausstellung von Tratten oder Bankgutschriften oder Bankwechseln; Abweichungen sind nur dann rechtswirksam, wenn sie von uns schriftlich genehmigt werden. Bei Zahlungsverzug hat ITALGRANITI GROUP das Recht, die laufenden Verträge aufzulösen, die Lieferungen einzustellen oder die Vorauszahlung – auch für andere Lieferungen – zu fordern sowie eine Spesenrückerstattung oder einen Schadensersatz geltend zu machen, ohne dass damit dem Käufer ein Recht auf Entschädigungen oder Sonstiges entsteht. Ferner hat jeder Zahlungsverzug eine unmittelbare Erhebung von Verzugszinsen in Höhe von fünf Punkten über dem zu jenem Zeitpunkt geltenden offiziellen Diskontsatz zur Folge. Eine vorausgehende Mahnung ist nicht erforderlich.

#### 7. Rückerstattung nicht geschuldeter Zahlungen

Darf der Käufer aus keinem Grund, auch nicht aus Garantieansprüchen wegen Mängel und Abweichungen, Zahlungen einstellen oder hinausschieben; unberührt davon bleibt das Recht auf Rückerstattung nicht geschuldeter Zahlungen.

#### 8. Eigentumsvorbehalt

Falls Zahlungen laut vertraglicher Vereinbarungen ganz oder teilweise nach der Lieferung geleistet werden sollen, bleiben die gelieferten Produkte bis zur vollständigen Entrichtung des Kaufpreises Eigentum von ITALGRANITI GROUP.

#### 9. Garantie

Die Produkte von ITALGRANITI GROUP sind für die Erfüllung der Güteanforderungen nach den geltenden UNI-EN-Normen garantiert. Die Angaben in Bezug auf Gewicht, Format, Abmessungen, Farbe, Farbnuancen sowie die anderen im gesamten Werbe- und Promotionsmaterial enthaltenen Angaben verstehen sich als Richtwerte und sind daher nicht verbindlich. In jeden Fall beschränkt sich die Garantie von ITALGRANITI GROUP auf Produkte erster Wahl, deren Anteil an defekten Fliesen nicht mehr als 5 % (fünf Prozent) beträgt. Jegliche Garantie für Sonderposten, Ware zweiter Wahl, Mindersortierungen oder Stockware bleibt ausdrücklich ausgeschlossen. Unterschiede in den Farbnuancen dürfen in keinem Fall als Mängel oder Materialfehler angesehen werden. Die Garantie ist für einen Zeitraum von zwei Jahren ab Lieferatum gültig.

#### 10. Reklamationen

Offensichtliche Mängel und Defekte müssen innerhalb von acht Tagen ab Lieferung gerügt werden, da sonst die Gewährleistungsansprüche des Käufers verfallen. Mängelrügen sind schriftlich an ITALGRANITI GROUP zu richten und müssen stets vor der Verlegung erfolgen. Der Käufer verpflichtet sich, das beanstandete Material für eine eventuelle Prüfung der Defekte zur Verfügung zu halten. Soweit weder Vorsatz noch grobe Nachlässigkeit vorliegen, ist ITALGRANITI GROUP, mit Ausnahme der Lieferung von Ersatzware, zu keiner Art von Schadensersatz verpflichtet.

#### 11. Anwendbares Recht und Gerichtsstand

Die Verträge unterliegen der Italienischen Rechtsprechung. Zuständiger Gerichtsstand ist Modena (Italien).

Condizioni generali di vendita

### FR Conditions générales de vente

#### 1. Règles contractuelles

Sauf éventuelles modifications ou dérogations convenues par écrit, les présentes conditions générales régèmentent tous les contrats de vente ayant pour objet les produits commercialisés par ITALGRANITI GROUP et conclus entre ITALGRANITI GROUP et l'acheteur. Toute variation des conditions générales de vente, transaction ou ristourne, même si elles sont dues à l'initiative de l'un de nos agents, démarcheurs ou autre intermédiaire, n'engageront ITALGRANITI GROUP qu'après une éventuelle confirmation par écrit et, en tout état de cause, relativement au seul contrat auquel elles se réfèrent.

#### 2. Proposition de commande

Les offres que les agents, démarcheurs ou autres intermédiaires présentent à l'acheteur et les propositions de commande que ceux-ci transmettent à ITALGRANITI GROUP n'engageront pas ITALGRANITI GROUP tant que la commande de l'acheteur n'aura pas été dûment acceptée par écrit.

#### 3. Confirmation de commande

Le contrat de vente sera réputé définitivement conclu lorsque l'acheteur aura reçu une confirmation de commande de la part de ITALGRANITI GROUP ou encore lorsque l'acheteur ou le transporteur que celui-ci aura choisi aura reçu l'instruction de charger la marchandise. L'éventuelle confirmation de commande de ITALGRANITI GROUP différente, en tout ou en partie, de la proposition de commande sera réputée obligatoire pour l'acheteur en l'absence de contestation de sa part par écrit dans un délai de dix jours à compter de la date de réception de la confirmation de commande.

#### 4. Livraison

La livraison est réputée effectuée à tous les effets auprès des entrepôts de ITALGRANITI GROUP au moment de la livraison de la marchandise au transporteur. Par conséquent, la marchandise voyage toujours aux risques et périls de l'acheteur et la responsabilité de ITALGRANITI GROUP cesse au moment de la livraison au transporteur. Les éventuelles réclmations concernant des dommages subis par la marchandise durant le transport devront dès lors être adressées exclusivement au transporteur. En ce qui concerne les ventes destinées à des pays de l'UE, le destinataire des marchandises s'engage à communiquer par écrit à ITALGRANITI GROUP le fait que la marchandise n'a pas été livrée auprès du lieu de destination indiqué dans le document de transport, ou que la marchandise a été livrée dans un lieu différent de celui qui est indiqué dans le document de transport, dans les trente jours qui suivent la date prévue de livraison : il enverra à cet effet, par courrier normal, télécopie ou courriel, ou par tout autre moyen, une déclaration appropriée et une copie du document de transport soussigné. Après avoir reçu la documentation susmentionnée, ITALGRANITI GROUP régularisera les factures émises en appliquant la TVA due au titre du DPR no 600/1973. Il reste entendu que le destinataire des marchandises s'engage à libérer ITALGRANITI GROUP des impôts, surtaxes, intérêts et sanctions in tout genre, ainsi que des débours si l'administration financière devait lui facturer des frais dérivant du fait qu'une telle communication écrite ne lui a pas été envoyée. Le destinataire des marchandises, après avoir pris acte de la communication qu' ITALGRANITI GROUP demandera de signer au transporteur, s'engage également à communiquer au transporteur en question tout changement ou toute modification de la destination de la marchandise. En cas de non-exécution de l'obligation susmentionnée, ITALGRANITI GROUP facturera au destinataire des marchandises les éventuels impôts, surtaxes, intérêts et sanctions in tout genre, ainsi que tout débours de nature légale, exigés par l'administration du fait qu'une telle communication ne lui a pas été envoyée.

#### 5. Délai de livraison

Le délai de livraison est à calculer à compter de la date de conclusion du contrat et, sauf dispositions contraires expressément prévues par écrit, est réputé purement indicatif et non essentiel. Si le délai de livraison est exprimé en jours, il se réfère aux jours ouvrables du calendrier en vigueur en Italie. Tout cas de force majeure interromp le décompte du délai de livraison pour toute la durée du cas de force majeure considéré. ITALGRANITI GROUP n'est nullement responsable pour des dommages dus à un retard de livraison ou à une absence de livraison (en tout ou en partie), à l'exception des cas de dol ou de faute grave.

#### 6. Paiement

Le lieu du paiement est réputé être notre siège administratif même en cas d'émission de traites, de reçus bancaires ou encore d'effets cambiarses sauf éventuelles dérogations que nous aurons concédées par écrit. Tout retard de paiement autorisera ITALGRANITI GROUP à mettre fin aux contrats en cours ou d'interrompre les livraisons de marchandises ou encore d'exiger le paiement anticipé (y compris concernant d'autres contrats) outre à réclamer le remboursement des frais supportés et le paiement des dommages et intérêts en raison des dommages éventuellement subis sans faculté pour l'acheteur de revendiquer quoi que ce soit, le paiement d'une indemnité ou autre chose. Par ailleurs, tout retard de paiement donnera immédiatement lieu à l'application d'intérêts moratoires à calculer au taux d'escompte officiel majoré de cinq points sans nécessité de mise en demeure préalable.

#### 7. Restitution des paiements indus

Sauf les cas de nullité, d'annulation et de résiliation du contrat, l'acheteur ne pourra suspendre ou retarder le paiement pour aucun motif que ce soit (y compris l'existence alléguée de vices ou d'un manque de conformité des produits), la faculté d'obtenir la restitution de sommes payées indûment demeurant en tout état de cause sauve.

#### 8. Clause de réserve de propriété

En cas d'accords contractuels prévoyant que le paiement doit être effectué, en tout ou en partie, après la livraison, ITALGRANITI GROUP demeurera propriétaire des produits livrés jusqu'au paiement de la totalité du prix.

#### 9. Garantie

Les produits de ITALGRANITI GROUP sont garantis conformes aux normes UNI-EN en vigueur. Les mentions concernant les poids, les dimensions, la couleur, la tonalité et toutes les autres données que le matériel publicitaire et promotionnel mentionne sont de nature purement indicative et sont dépourvues de tout caractère obligatoire. En tout état de cause, la garantie que fournis ITALGRANITI GROUP est limitée aux produits de premier choix avec un pourcentage de carreaux défectueux n'excédant pas 5% (cinq pour cent) ; il est expressément précisé que la garantie ne s'applique pas aux produits de qualité variable, seconde ou inférieure et aux produits de stock. Les différences de tonalité ne pourront jamais être considérées comme constituant un vice ou un défaut du produit. La garantie a une durée de deux ans à compter de la date de livraison. La garantie susmentionnée substitue les garanties légalement prévues en ce qui concerne les vices et les défauts et elle exclut toute autre forme de responsabilité de la part de ITALGRANITI GROUP.

#### 10. Réclamations

Sous peine de déchéance, les vices et les défauts apparents doivent être signalés dans les huit jours à compter de la livraison ; les vices et les défauts non visibles doivent être signalés sous peine de déchéance dans les huit jours à compter de la constatation de leur existence. La réclamation devra être adressée à ITALGRANITI GROUP par écrit et devra être effectuée avant toute pose des produits. L'acheteur s'engage à tenir les produits contestés à disposition afin que la présence des défauts puisse être dûment vérifiée. En tout état de cause, ITALGRANITI GROUP ne sera tenu aux dommages et intérêts sauf les cas de dol ou de faute grave, l'éventuelle possibilité de remplacer le produit concerné demeurant sauve.

#### 11. Droit applicable et clause d'arbitrage international

A l'exception des litiges relatifs au paiement du prix qui restent de la compétence des tribunaux étatiques, toute contestation survenant à l'occasion de l'exécution, de l'interprétation ou de la rupture du présent contrat sera résolue par arbitrage. L'arbitrage est confié à un Collège d'arbitres constitué d'un arbitre nommé par chacune des parties et d'un troisième arbitre nommé d'un commun accord, ou en cas de désaccord, par le Président de la C.C.I.A.A. (Chambre de Commerce) de Modena (Italie) à la demande de la partie la plus diligente. La partie qui entend engager une procédure arbitrale doit notifier à l'autre partie par lettre recommandée le nom de l'arbitre qu'elle a choisi ainsique son acceptation. L'autre partie doit nommer son propre arbitre dans les quinze jours de la réception de la lettre recommandée, en communiquant ladite nomination et l'acceptation relative dans le délai indiqué. A défaut, l'autre partie sera en droit de demander la nomination d'un second arbitre par le Président de la C.C.I.A.A. (Chambre de Commerce) de Modena (Italie). L'arbitrage a comme siège Modène (Italie), comme langue l'italien et comme loi applicable le droit italien.

#### 12. Politique de confidentialité

Conformément à l'art. 13 du règlement UE 2016/679 ITALGRANITI GROUP SA, Mandataire de Données, souhaite vous informer que vos données personnelles seront traités uniquement pour cibles commerciales et contractuelles. Pour cela, ils pourront être diffusés aux sujets autorisés internes ou externes à l'entreprise, mais toujours sous le contrôle de ITALGRANITI GROUP SA. Vous pouvez à tout moment faire opposition et exercer vos droits. Merci de vous connecter à [www.italgranitigroup.com](http://www.italgranitigroup.com) pour télécharger les documents d'information.

Italgraniti Group si riserva la facoltà esclusiva di modificare e sostituire, anche solo parzialmente, i prodotti illustrati in questo catalogo senza l'obbligo di darne preavviso. Le informazioni contenute nel presente catalogo sono il più possibile esatte ed aggiornate al momento della stampa, pertanto i dati elencati possono subire variazioni. I colori e le tonalità delle piastrelle qui riprodotti sono indicativi.

Per approfondimenti consulta i nostri video tutorial sul sito e sul canale YouTube.

Italgraniti Group behält sich das Recht vor, Teile der in diesem Katalog aufgeführten Produkte ohne vorherige Ankündigung zu ändern oder zu ersetzen. Die im vorliegenden Katalog enthaltenen Angaben sind so genau wie möglich gehalten und sind zum Ausgabedatums richtiggestellt worden. Jeweilige Veränderungen entsprechender Angaben sind somit vorbehalten. Die her abgebildeten Farbtöne der Fliesen sind lediglich zur Orientierung gedacht.

Weitere Informationen finden Sie in unseren Video-Tutorials auf der Website und auf dem YouTube-Kanal.

Italgraniti Group reserves the right to modify and replace the materials illustrated in this catalogue, even only partially and with no obligation to give notice thereof. The information contained in this catalogue is correct to the best of our knowledge and updated at the catalogue printing time; therefore the listed data can be altered. The colours and shades shown here are only indicative.

For more details, check our tutorial videos on the website and on YouTube.

Italgraniti Group se réserve le droit de modifier et de replacer sans aucun préavis, même partiellement, les articles présentés dans ce dépliant. Les reinsegnements données dans ce catalogue sont le plus possible exacts et ajournés au moment où le catalogue est imprimé, c'est pourquoi les données peuvent subir de variations. Les couleurs et les tonalités des carreaux ici reproduits sont indicatives.

Pour plus d'informations, regardez les vidéos disponibles sur notre site et sur notre chaîne YouTube.



Website

Follow us on



**PRINTED IN ITALY**

January 2026



**Italgraniti Group S.p.A.**

Via Radici in Piano 355  
41043 Formigine - Modena - Italy  
Tel +39 059 888411  
Fax +39 059 848808  
www.italgranitigroup.com  
info@italgranitigroup.com  
project.department@italgranitigroup.com

**Flagship Store**

Via Statuto 21  
20121 - Milano - Italy  
Tel +39 02 84567687  
milano@italgranitigroup.com

**ITALGRANITI**  
EXCLUSIVE ITALIAN SURFACES



[italgranitigroup.com](http://italgranitigroup.com)

