

ROMA

Eterna bellezza



FAP
CERAMICHE
Naturalmente casa.

ROMA

Eterna bellezza

8

STATUARIO

22

GRAFITE

26

TRAVERTINO

34

PIETRA

44

IMPERIALE

54

CALACATTA



WALL & FLOOR

Roma è un progetto ceramico completo di pavimenti e rivestimenti per circondare di bellezza i vostri spazi.

Roma is a complete ceramic programme of floor and wall tiles to encase your rooms with a sensation of beauty.

Roma représente un projet céramique complet composé de sols et de murs qui saura valoriser vos espaces de vie. / Roma ein vollständiges Keramikprojekt für Fußböden und Verkleidungen der Ihren Raum mit Schönheit umgibt. / Roma es un proyecto cerámico completo de pavimentos y revestimientos para inundar vuestros espacios de belleza. / Roma — это универсальный проект напольной и настенной плитки, приносящей в ваш дом истинную красоту.

MARMO E PIETRA MARBLE & STONE

Roma esprime con fascino contemporaneo la bellezza del marmo e della pietra. Sei colori interpretano con grandi lastre una nuova estetica progettuale, senza limiti, senza tempo.

Roma lends contemporary appeal to the beauty of marble and stone. Six colours and large slabs for a new aesthetic project that is timeless and knows no limits.



MARBRE ET PIERRE. Roma exprime la beauté du marbre et de la pierre avec un charme contemporain. Sur de grandes plaques, six couleurs interprètent une nouvelle esthétique conceptuelle, sans limite et sans contrainte. / MARMOR UND STEIN. Roma bringt die Schönheit des Marmors und des Steins mit zeitgemäßen Charme zum Ausdruck. Sechs Farben interpretieren mit großen Platten eine neue Planungsästhetik, grenzenlos und zeitlos. / MARMOL Y PIEDRA. Roma refleja con un moderno atractivo la belleza del mármol y de la piedra. Seis colores interpretan junto con grandes losas una nueva estética proyectual sin límites ni tiempo. / Мрамор и КАМЕНЬ. Roma передает в современном ключе красоту мрамора и камня. В шести тональностях крупноформатной плитки выражена новая дизайнерская эстетика: без границ и вне времени.

STATUARIO

puro e perfetto / pure and perfect

PASTA BIANCA
WHITE BODY



50x120 RT



50x120 RT



25x75



25x75

pur et parfait
Perfekt und rein
puro y perfecto
чистая и безупречная

GRES PORCELLANATO
PORCELAIN STONEWARE



80x80 RT



60x60 RT



MY LIVING

Pavimento e rivestimento, il puro fascino dello Statuario e del grande formato.

Wall and floor coverings, the pure attraction of Statuario and large size.



Sols et murs, le charme de Statuario et du grand format à l'état pur. / Fußboden und Wandverkleidung, der reine Charme des Statuario und des großen Formats. / Pavimento y revestimiento, la atracción pura del Statuario y del gran formato. / Настенная и напольная плитка, непревзойденное очарование линии Statuario и крупного формата.



Wall
Roma Statuario
Roma Filo Statuario

Floor
Roma Statuario

LA SUPERFICIE DECORA SURFACES FOR DECORATION

*Tridimensionale nella struttura Filo, o elegante fondo, è sempre la materia la vera decorazione.
Whether it is the three dimensional texture of Filo or the elegant tile, the real decoration is always the material.*



C'EST LA MATIERE QUI DECORE. Tridimensionnel dans sa structure Filo, ou élégante base unie, c'est la matière qui constitue la véritable décoration. / **DIE OBERFLÄCHE DEKORIERT.** Das 3D- Dekor Filo oder eine elegante Grundfliese, die Dekoration liegt immer in der Materie. / **LA SUPERFICIE DECORA.** Tridimensional en la estructura Filo, o fondo elegante, la materia resulta ser siempre la auténtica decoración. / **ПОВЕРХНОСТЬ УКРАШАЕТ.** Объемная структура Filo или элегантная фоновая плитка — в центре внимания неизменно сам материал.



Wall
Roma Statuario
Roma Natura
Statuario Mosaico



*Mosaico Natura,
listello cromato Silver
e il formato del rivesti-
mento 25x75 rendono
tutto contemporaneo.*

*Natura Mosaic, Silver
chrome listel and the
25x75 wall covering
shape make everything
look contemporary.*

Mosaïque Natura, listel chromé Silver et format 25x75 au mur, une association qui apporte à l'espace une réelle touche de modernité. / Mosaik Natura, die verchromte Leiste Silver und die Wandverkleidung im Format 25x75 lassen alles zeitgemäß erscheinen. / Mosaico Natura, listel cromado Silver y el formato del revestimiento 25x75 confieren siempre modernidad. / Мозаика Natura, хромированный бордюр Silver и формат настенной плитки 25x75 преобразуют помещение в современном стиле.



Stair
Roma Statuario

Floor
Roma Grafite

UNA MATERIA SENZA TEMPO

A TIMELESS MATERIAL

Una gamma completa di pezzi speciali per coordinare perfettamente ogni ambiente della casa. Pavimento, scalino e battiscopa.

A full range of trim tiles to coordinate all the spaces in the home to perfection. Flooring, step and skirting tiles.

UNE MATIÈRE INTEMPORELLE. Un programme complet de pièces spéciales pour revêtir à la perfection chaque espace de la maison. Sol, marche et plinthe. / EINE ZEITLOSE MATERIE. Eine vollständige Auswahl von Spezialteile für eine perfekte Raumkoordination Ihres Heims. Fußboden, Stufe und Fußleiste. / UNA MATERIA A TEMPORAL. Una gama completa de piezas especiales para coordinar a la perfección cada ambiente de la vivienda. Pavimento, escalera y zócalo. / НЕПРЕХОДЯЩАЯ МАТЕРИЯ. Идеальное завершение всех помещений вашего дома благодаря полной гамме специальных элементов. Напольная плитка, ступенька и плинтус.



Wall
Roma Statuario
Floor
Roma Righe Statuario Grafite Matt

SHOP SIMPLY CHIC

*Una grande bellezza per realizzare spazi commerciali contemporanei.
Il vero lusso: personalizzarli con sofisticate decorazioni.*

*True beauty for contemporary commercial applications.
True luxury: customisation with sophisticated decorations.*



Le maximum de l'esthétique pour réaliser des espaces commerciaux contemporains. Et pour encore plus de classe, apportez leur une touche de personnalité avec quelques décors. / Eine wunderbare Schönheit für die Erschaffung von zeitgemäßen kommerziellen Räumlichkeiten. Der wahre Luxus: Personalisierung mit raffinierten Dekorationen. / Una gran belleza para realizar espacios comerciales contemporáneos. El auténtico lujo: personalizarlos con sofisticadas decoraciones. / Красота стиля для реализации современных деловых помещений. Придание индивидуальности благодаря изысканным декорам — это настоящая роскошь.

GRAFITE

elegante e profondo / elegant and profound

GRES PORCELLANATO
PORCELAIN STONEWARE

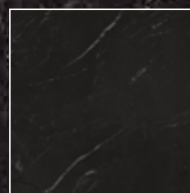

80 x 80 RT

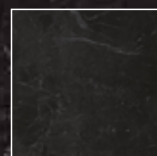

60 x 60 RT

élégant et profond
Elegant und tief
elegante y profundo
элегантная и глубокая

ELEGANT CONTEMPORARY

*La seduzione del marmo e
l'affidabilità del gres porcel-
lanato: partner perfetti per
locali esclusivi.*

*The seduction of marble and
the reliability of porcelain
stoneware: ideal partners for
exclusive spaces.*

Wall
Roma Statuario

Floor
Roma Grafite

La séduction
du marbre et
la fiabilité du
grès cérame :
des partenaires
parfaits pour
des espaces
exclusifs. / Die
Verführung des
Marmors und die
Zuverlässigkeit
des Feinsteinzeu-
gs: Perfekte Part-
ner für exklusive
Räume. /
La seducción
del mármol y
la fiabilidad del
gres porcelánico:
excelente com-
binación para lo-
cales exclusivos.
/ Очарование
мрамора и
надежность
керамогранита:
идеальное
сочетание для
оформления
эксклюзивных
помещений.

TRAVERTINO

ricco e naturale / rich and natural

riche et naturel
Reich und natürlich
rico y natural
роскошная и естественная

PASTA BIANCA
WHITE BODY



25 x 75 25 x 75

GRES PORCELLANATO
PORCELAIN STONEWARE



80 x 80 RT 60 x 60 RT



Wall
Roma Travertino
Roma Filo Travertino
Roma Natura Travertino Mosaico

Floor
Roma Travertino Matt

FASCINO NATURALE NATURAL ATTRACTION

Naturali striature circondano lo spazio. Nella doccia, il mosaico Natura e la versatile materia esprimono soluzioni architettoniche affascinanti.

Natural veins encasing the space. In the shower, the Natura mosaic and the versatile material express attractive architectural solutions.



CHARME NATUREL. Les striures naturelles présentes entourent l'espace. Dans la douche, la mosaïque Natura et la matière très éclectique donnent naissance à des solutions architectoniques particulièrement intéressantes. / NATÜRLICHER CHARME. Natürliche Verläufe umgeben den Raum. In der Dusche strahlen das Mosaik Natura und die vielseitige Materie charmante architektonische Lösungen aus. / ATTRACTIVO NATURAL. Vetas naturales rodean el espacio. En la ducha, el mosaico Natura y la versátil materia muestran excelentes soluciones arquitectónicas. / ОЧАРОВАНИЕ ПРИРОДЫ. Естественное рифление наполняет пространство. В душевой кабине мозаика Natura и многофункциональная керамика воплощают восхитительные архитектурные решения.



GLAM GYM

*Atmosfera sofisticata,
sensazioni naturali.*

*Sophisticated atmosphere,
natural sensations.*

Wall
Roma Travertino

Floor
Roma Travertino

Une atmosphère captivante,
des sensations naturelles. /
Raffinierte Atmosphäre, natür-
liche Sensationen. / Atmós-
fera sofisticada, sensaciones
naturales. / Утонченная
атмосфера, соприкосновение
с природой.

PIETRA

raffinata e accogliente / elegant and inviting

raffinée et accueillante
Raffiniert und einladend
refinada y acogedora
изысканная и уютная

PASTA BIANCA
WHITE BODY



50x120 RT



50x120 RT



25x75



25x75

GRES PORCELLANATO
PORCELAIN STONEWARE



80x80 RT



60x60 RT



Wall

Roma Pietra
Roma Filo Pietra
Roma Pietra Mosaico

Floor

Roma Pietra Matt



Differenti e morbide vibrazioni di luce decorano la materia in un mood perfettamente coordinato.

The soft and changing shimmering light decorates the material with a mood that is perfectly coordinated.



Des reflets de lumière, doux et ondoyants, animent cet espace ou tout apparait coordonné avec juste équilibre. / Verschiedene und sanfte Vibrationen von Licht schmücken die Materie in einem perfekt koordinierten Mood. / Distintas vibraciones suaves de luz decoran la materia con un estilo perfectamente coordinado. / Разнообразные мягкие световые блики придают плитке безупречное единство стиля.



Wall
Roma Pietra
Roma Classic Pietra
Roma Classic Pietra Listello
Floor
Roma Pietra Matt

NEW CLASSIC



L'eleganza tridimensionale del decoro Classic sul calore screziato della Pietra: un nuovo classico che sorprende per contemporaneità.

The three dimensional elegance of the Classic decoration on the grainy warmth of Pietra: a new classic whose contemporary mood is astonishing.

L'élégance et le chic du relief du décor Classic en opposition à l'ardeur jaspée de Pietra : un classique insolite qui surprend par sa modernité. / Die 3D-Eleganz des Dekors Classic auf dem natürlichen Farbverlaufs des Pietra: ein neuer Klassiker, der mit seinem modernen Einklang überrascht. / La elegancia tridimensional de la decoración Classic en el cálido vetado de la Pietra: un nuevo clásico que sorprende por su modernidad. / Элегантность трехмерного декора Classic выражена теплыми крапинками Pietra: новая классика, поражающая своей современностью.

Pietra e Imperiale, un abbinamento sofisticato, esaltato dalle infinite possibilità progettuali di Roma.

Pietra and Imperiale a sophisticated combination emphasised by the infinite design possibilities of Roma.



Wall
Roma Pietra
Roma Imperiale
Roma Natura Imperiale Mosaico

Floor
Roma Imperiale



Pietra et Imperiale, un mariage recherché, relevé par les innombrables possibilités conceptuelles de Roma. / Pietra und Imperiale, eine raffinierte Kombination mit unendlichen Planungsmöglichkeiten von Roma. / Pietra e Imperiale, una sofisticada combinación exaltada por infinitas posibilidades proyectuales de Roma. / Pietra и Imperiale, утонченное сочетание, подчеркнутое бесконечными дизайнерскими возможностями Roma.

IMPERIALE

s sofisticato e singolare / sophisticated and unusual

sophisticqué et singulier
Raffiniert und einmalig
sofisticado y singular
утонченная и уникальная

PASTA BIANCA
WHITE BODY



50x120 RT



50x120 RT



25x75

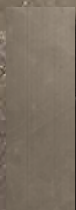

25x75

GRES PORCELLANATO
PORCELAIN STONEWARE



80x80 RT



60x60 RT



Wall
Roma Imperiale
Roma Filo Pietra

Floor
Roma Imperiale

WELCOME STYLE

*Roma, la collezione perfetta per donare alla vostra accoglienza lo stile desiderato.
Roma, the ideal collection to welcome your guests in perfect style.*



Roma, la toile de fond idéale pour recevoir vos amis dans un cadre d'un grand style. / Roma, die perfekte Kollektion die Ihrem Empfang und Begrüßung den gewünschten Stil verleiht. / Roma, la colección perfecta para otorgarle a su recibimiento el estilo deseado. / Roma, идеальная коллекция для придания вашему гостеприимству индивидуального стиля

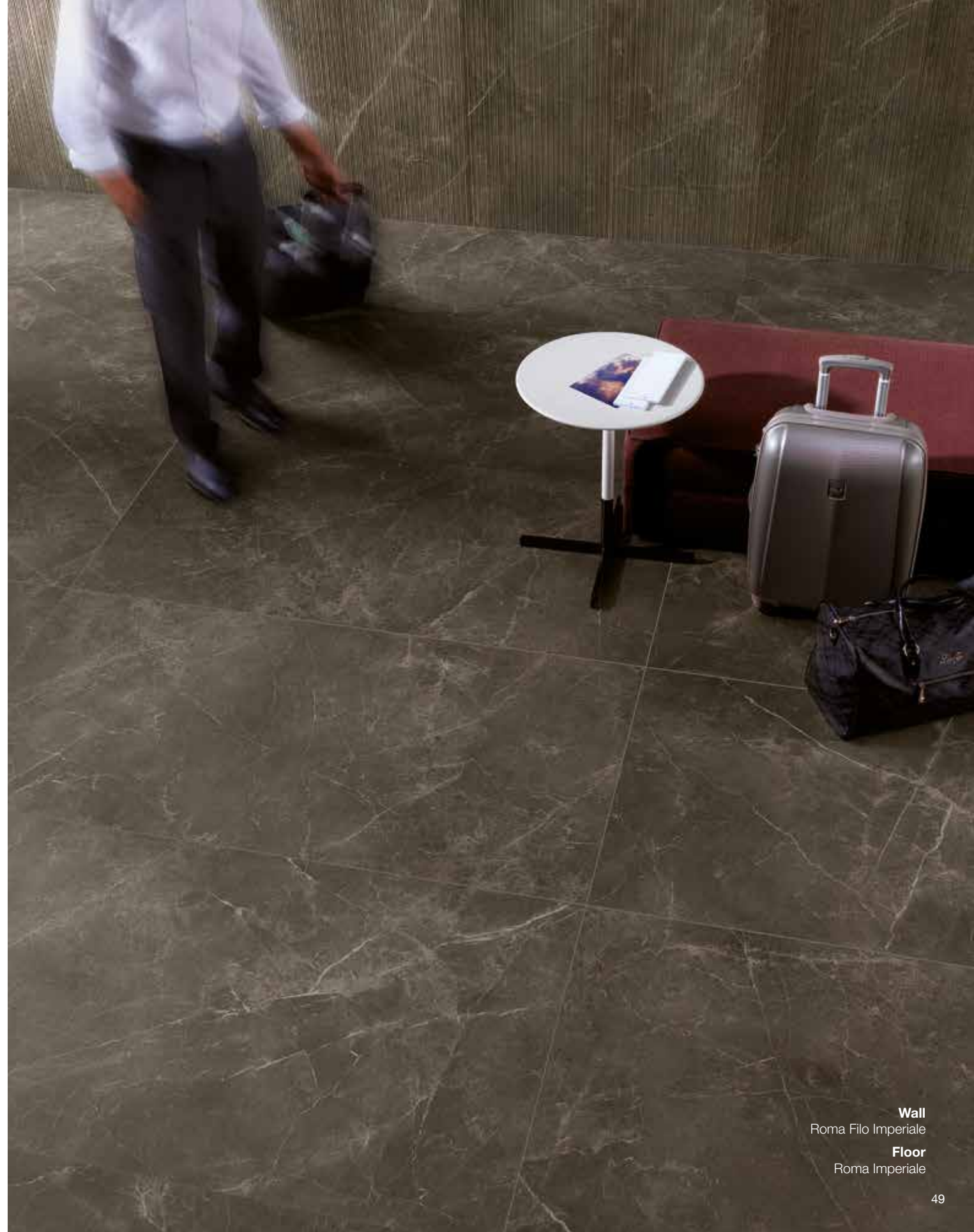

Wall
Roma Filo Imperiale
Floor
Roma Imperiale



Wall
Roma Imperiale
Roma Filo Imperiale
Floor
Roma Imperiale Matt

BELLEZZA AVVOLGENTE ENVELOPING BEAUTY

*Ogni lastra è un pezzo unico.
Una naturale meraviglia fatta di
differenti e spontanee venature.*

*Each slab is unique. A natural
wonder made up of different and
spontaneous veins.*



UNE BEAUTÉ CAPTIVANTE. Chaque plaque est une pièce unique. Une merveille naturelle faite de veinures variées et spontanées. / MITREISSENDE SCHÖNHEIT. Jede Platte ist einzigartig. Ein natürliches Wunder, welches aus unterschiedlichen Verläufe besteh. / ENCANTADORA BELLEZA. Cada losa es una pieza única. Una maravilla natural hecha con diferentes y espontáneas vetas. / ЧАРУЮЩАЯ КРАСОТА. Каждая плитка — это уникальный элемент, будто созданный самой природой из неодинаковых произвольных прожилок.

La materia è qui protagonista come decorativo drappeggio e come elemento essenziale per un perfetto piano lavabo.

Here the material is in the spotlight in decorative folds and an essential element for a perfect top for a washbasin.



La matière joue ici un rôle de drapé décoratif et d'élément essentiel, pour un plan de toilette parfait. / Die Materie, Hauptdarsteller als dekorativer Vorhang und als essentielles Element für ein perfektes Waschbecken. / La materia es aquí protagonista como decoración drapeada y elemento esencial para una perfecta encimera de lavabo. / Материя выступает здесь и как роскошная драпировка, и как основной элемент в оформлении зоны раковины.

CALACATTA

caldo e pregiato / warm and precious

prestigieux et chaleureux
Warm und wertvoll
cálido y precioso
Теплая и драгоценная

PASTA BIANCA
WHITE BODY



50 x 120 RT



50 x 120 RT



25 x 75



25 x 75

GRES PORCELLANATO
PORCELAIN STONEWARE



80 x 80 RT



60 x 60 RT



Wall
Roma Calacatta

Floor
Roma Calacatta

RAFFINATO CALORE ELEGANT WARMTH

*80x160, la meraviglia del marmo,
la praticità del Gres porcellanato.*

*80x160, the wonder of marble,
the practical features of porcelain stoneware.*

UNE CHALEUR ENVELOPPANTE. 80x160, le charme du marbre, les qualités pratiques du grès cérame. / RAFFINIERTA WÄRME. 80x160, wunderbarer Marmor und praktisches Feinsteinzeug. / REFINADO CALOR. 80x160, la maravilla del mármol, la practicidad del Gres porcelánico. / ИЗЫСКАННОЕ ТЕПЛО. 80x160 - красота мрамора, практичность керамогранита.

Raffinato e decò: Roma possiede tutti gli elementi decorativi necessari per realizzare lo stile che desideri.

Elegant and decò: Roma has all the decorative elements you need to create the style you want.



Wall

Roma Calacatta Alzata
Roma Calacatta Matita
Roma Greca Calacatta Listello
Roma Calacatta
Roma Calacatta London

Floor

Roma Calacatta



Raffiné et decò : Roma possède tous les éléments décoratifs nécessaires aux recherches de style les plus exigeantes. / Raffiniert und decò: Roma besitzt sämtliche dekorative Elemente für die Realisierung des gewünschten Stils. / Refinada y decò: Roma posee todos los elementos decorativos necesarios para realizar el estilo deseado. / Изысканность и decò: плитка Roma включает все декоративные элементы, необходимые для воплощения вашего персонального стиля.



Wall
Roma Calacatta
Roma Filo Calacatta



VERI INTARSI REAL INTARSIA

*Dalla materia incisa emergono
delicate decorazioni.*

*Delicate decorations emerge
from the engraved material.*

DE VÉRITABLES MARQUETÉRIES.
De la matière incisée naissent
d'élégants décors. / ECHTE IN-
TARSIEN. Die eingravierte Materie
lässt zarte Dekorationen entstehen.
/ AUTÉNTICOS INSERTOS. De la
materia incisa emergen delicadas
decoraciones. / НАСТОЯЩАЯ
ГРАВИРОВКА. Гравированная
плитка превращается в истинное
украшение.

SIAMO CERAMICA

UNA SCELTA CONSAPEVOLE

WE ARE CERAMICS

A MINDFUL CHOICE

NON BRUCIA
DOES NOT BURN

SICURA PER LA SALUTE
SAFE FOR HEALTH

IL MASSIMO DELL'IGIENE
MAXIMUM HYGIENE

RESISTE A TUTTO
RESISTANT TO EVERYTHING

VERSATILE
VERSATILE

ECOLOGICA
ECO-FRIENDLY

comunicazione e marketing in partnership con:
community e social media in partnership with:

ceramica.info

www.ceramica.info

Gres porcellanato pezzi speciali

Porcelain Stoneware special trims

Pièces spéciales grès cérame

Feinsteinzeug-formteile

Piezas especiales gres porcelánico

Специальные элементы из керамогранита

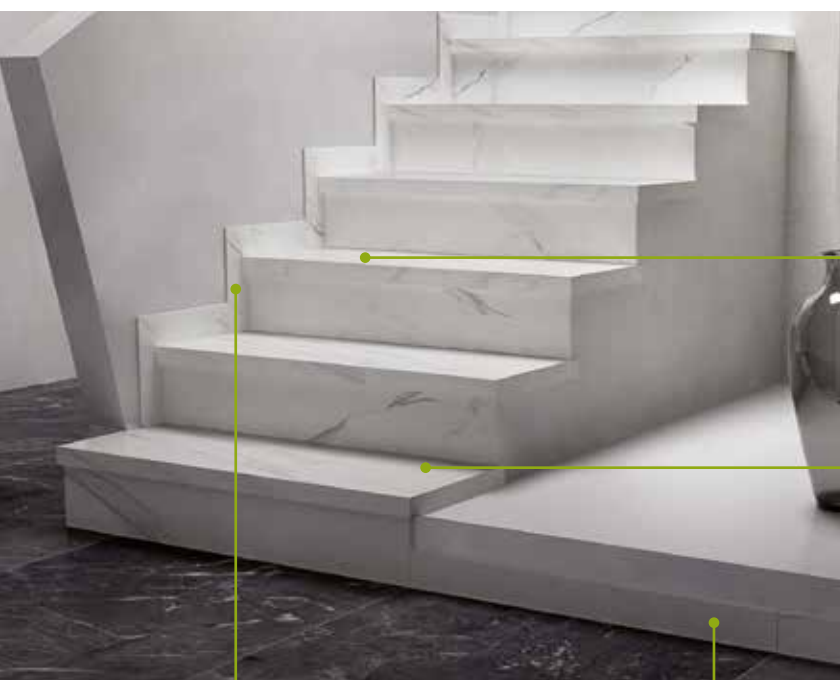

SCALINO

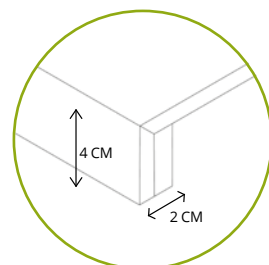

SCALINO ANGOLARE

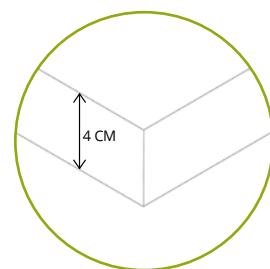

BATTISCOPIA SAGOMATO

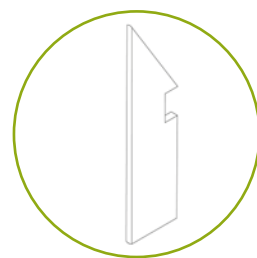

BATTISCOPIA

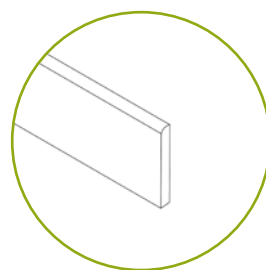

Destinazione d'uso

Destination of use

Utilisation prévue

Verwendungszweck

Destinos de uso

Область применения

MEDIUM WALKING

ambienti commerciali medi con accessi non diretti con l'esterno o protetti da zerbini come ristoranti, bar, negozi, hotel, biblioteche, business lounge, banche, ad esclusione di passaggi obbligati. Ideale anche per ambienti residenziali.

commercial environments with medium foot traffic: with non-direct outside access or access protected with doormats, such as restaurants, bars, shops, hotels, libraries, business lounges, banks, except for areas with obligatory passages. Also ideal for residential settings



espaces commerciaux soumis à un piétinement moyen avec accès non directs de l'extérieur ou protégés par des paillasons, tels que les restaurants, les cafés, les boutiques, les hôtels, les bibliothèques, les espaces affaires et les banques, à l'exception des lieux de passage obligatoires. Idéal aussi dans les espaces résidentiels.

Gewerberäume mit mittlerer Begehungsfrequenz: Räumlichkeiten ohne direkten Zugang von außen oder durch Fußmatten geschützte Bereiche wie Restaurants, Bars, Geschäfte, Hotels, Bibliotheken, Business Lounges und Banken mit der Ausnahme von Durchgangsbereichen. Auch für den Wohnbereich ideal.

ambientes comerciales medios: con accesos indirectos al exterior o protegidos por felpudos como restaurantes, bares, tiendas, hoteles, bibliotecas, business lounge, bancos, exceptuándose los pasajes obligatorios. Perfecto también para ambientes residenciales.

деловые помещения со средним уровнем проходимости: без прямого выхода на улицу или защищенные входными ковровыми покрытиями: рестораны, магазины, гостиницы, библиотеки, бизнес-залы, банки, за исключением обязательных зон прохода. Идеально подходит для жилых пространств.

Wall tiles

Piastrelle rettificate in pasta bianca,
pareti senza fughe

Rectified white body tiles,
jointless walls

Noi realizziamo piastrelle e ne tagliamo i bordi per renderle a “spigolo vivo”, questo permette di posarle senza fuga, così le pareti sono superfici continue, lisce e perfette, le fughe quasi invisibili. Oltre ai benefici estetici, non trattengono lo sporco e facilitano la pulizia.

We create tiles and cut the edges. These “sharp-edge” tiles can be laid without joints, for perfectly smooth, continuous surfaces, with the joints barely noticeable. In addition to the aesthetic advantages, these tiles prevent dirt from gathering and are thus easy to clean.

FORMATS RECTIFIÉS, POSE À JOINT RÉDUIT

Nous réalisons des carreaux que nous rectifions pour obtenir des bords parfaitement droits qui permettent une pose à joints réduits. Les murs apparaissent ainsi plus uniformes et continus car le joint est presque invisible. Ceci constitue non seulement un avantage esthétique, les espaces apparaissent plus grands, mais également fonctionnel : la saleté s'y loge en effet moins facilement et l'entretien est plus aisé.

GESCHLIFFENE FLIESEN, FUGENLOSE WÄNDE

Wir produzieren Fliesen und schneiden die Kanten, um «scharfe Kanten» zu erhalten. Dies bedeutet, dass sie nahtlos verlegt werden können, sodass die Oberflächen durchgehend, glatt und perfekt sind und die Fugen kaum sichtbar sind. Zusätzlich zu den ästhetischen Vorteilen wird Schmutz nicht eingeschlossen und die Reinigung wird erleichtert.

LOSAS RECTIFICADAS, PAREDES SIN JUNTAS

Realizamos losas y cortamos los bordes para que sean de “arista viva”, lo que permite colocarlas sin juntas; de esta manera las superficies de las paredes son continuas, lisas y perfectas y las juntas son casi invisibles. Además de los beneficios estéticos, no retienen la suciedad y facilitan la limpieza.

ОСНОВНАЯ ПЛИТКА, БЕСШОВНАЯ СТЕНКА

Мы производим плитки и дорабатываем края, чтобы создать «живой край». Это позволяет использовать бесшовную технику укладки, которая гарантирует непрерывность, гладкость и совершенство поверхностей с почти невидимыми швами. В дополнение к эстетическим преимуществам, этот стиль не задерживает грязь и облегчает стирку, отражают совершенное сочетание керамических традиций и находок современного дизайна.

RETTIFICHIAMO LE PIASTRELLE CON UN TAGLIO LEGGERMENTE INCLINATO PER CONSENTIRE LA POSA ACCOSTATA:

- ▶ posa senza sbecatura
- ▶ penetrazione agevolata dello stucco

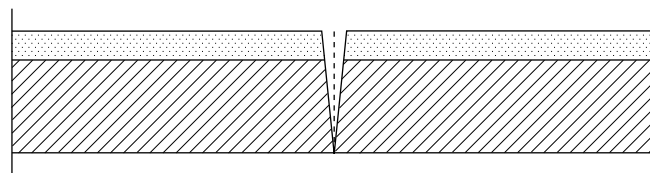

WE RECTIFY THE TILES WITH A SLIGHTLY DIAGONAL CUT, ALLOWING FOR FLUSH LAYING:

- ▶ laying without cracks
- ▶ makes it easier for the grout to penetrate

LA RECTIFICATION DES CARREAUX PRÉVOIT UNE COUPE AVEC UN LÉGER BIAIS POUR FACILITER LA POSE À JOINTS RÉDUITS :

- LES BORDS DES CARREAUX SONT MOINS EXPOSÉS À DES ÉCLATS
- LE MORTIER JOINT PÉNÈTRE PLUS FACILEMENT

WIR SCHLEIFEN DIE FLIESEN MIT EINEM LEICHT GENEIGTEN SCHNITTWINKEL, UM SIE NEBENEINANDER VERLEGEN ZU KÖNNEN:

- VERLEGEN OHNE ANGESCHLAGENEN RÄNDER
- LEICHTERES EINDRINGEN DER FUGENMASSE

RECTIFICAMOS LAS LOSAS CON UN CORTE LIGERAMENTE INCLINADO PARA PERMITIR LA COLOCACIÓN UNIDA:

- COLOCACIÓN SIN ASTILLADOS
- PENETRACIÓN FACILITADA DEL MORTERO DE REJUNTADO

МЫ ВЫРАВНИВАЕМ КРАЯ ПЛИТКИ, ОБРЕЗАЯ ИХ ПОД ЛЕГКИМ НАКЛОНОМ, ЧТО ПОЗВОЛЯЕТ ПРОИЗВОДИТЬ БЕСШОВНУЮ УКЛАДКУ:

- УКЛАДКА БЕЗ НЕРОВНОСТЕЙ
- БЕСПРЕПЯТСТВЕННОЕ ПРОНИКНОВЕНИЕ ШТУКАТУРКИ

PEZZI SPECIALI / TRIMS

WALL TILES

PIÈCES SPÉCIALES / FORMTEILE /

PIEZAS ESPECIALES / СПЕЦИАЛЬНАЯ СЕКЦИЯ

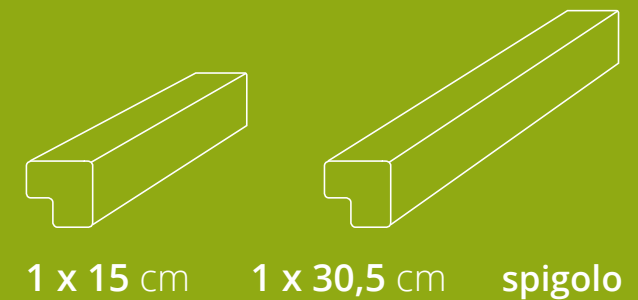

1 x 15 cm 1 x 30,5 cm spigolo



1 x 1 cm
angolo esterno spigolo



Roma Pietra Silk 120x278 RT V2 

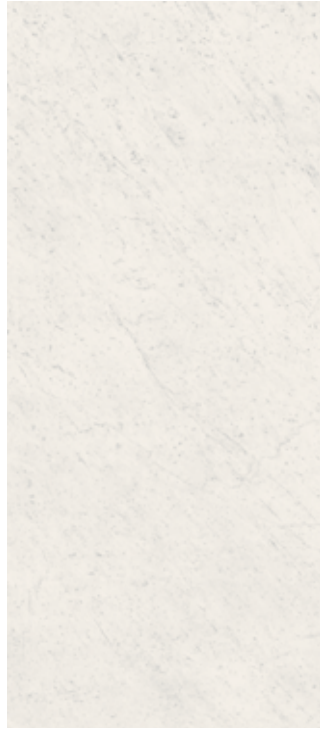

Roma Carrara Silk 120x278 RT V2 



Roma Calacatta Silk 120x278 RT V3 

Questi articoli sono caratterizzati da una grande variabilità delle venature fra le lastre.
These items feature a significant variability of veining effects on the slabs.



Wall: Roma Diamond Carrara Silk - Floor: Color > Now Grigio Silk

	Unità di vendita Sales unit	MQ./Box	PZ./Box	Kg/Box	Box/PL
	1 Box	3,336	1	47,94	18



Roma Statuario Matt V3



Roma Grafite Matt V2



Roma Calacatta Matt V3



Roma Pietra Matt V2



Roma Imperiale Matt V2



Roma Travertino Matt V2

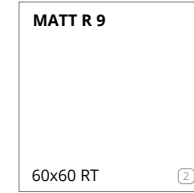
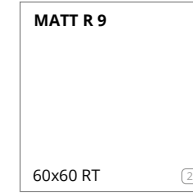
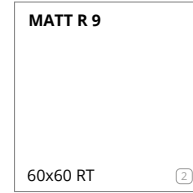
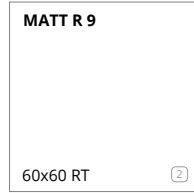
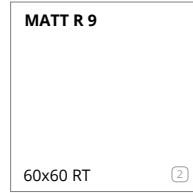
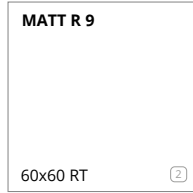
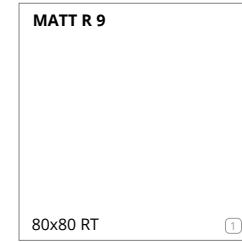
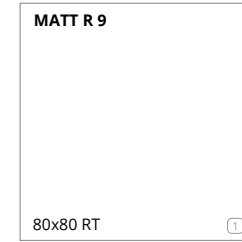
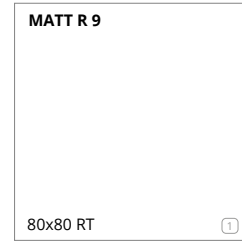
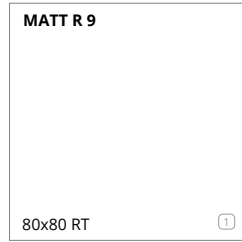
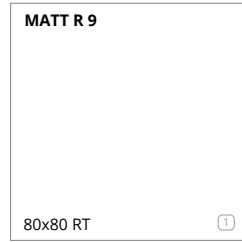
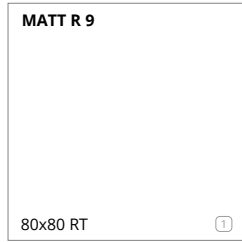

	Unità di vendita Sales unit	MQ./Box	PZ./Box	Kg/Box	Box/PL
①	1 Box	1,280	2	24,90	48
②	1 Box	1,080	3	21,70	40
③	1 Box	1,260	7	25,00	40

Classification UPEC
Seul le site du CSTB fait foi, pour vérifier les classements indiqués, merci de consulter le site <https://evaluation.cstb.fr/>



Roma Righe Statuario Grafite Matt Inserto 60x60 RT ①



Roma Righe Calacatta Imperiale Matt Inserto 60x60 RT ①



Roma Righe Matt Inserto

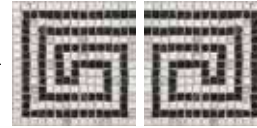

fMGU Roma Greca Statuario Grafite Mosaico Mix 2 20x40 ②

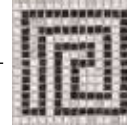

fMAQ Roma Angolo Greca Statuario Grafite Mosaico 20x20 ③



MOSAICO



Roma Round Statuario Mosaico*** 29,5x32,5 ④



Roma Round Calacatta Mosaico*** 29,5x32,5 ④



Roma Round Imperiale Mosaico*** 29,5x32,5 ④



Roma Round Travertino Mosaico*** 29,5x32,5 ④



Roma Round Pietra Mosaico*** 29,5x32,5 ④

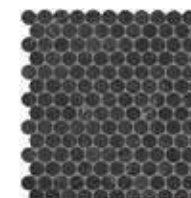

Roma Round Grafite Mosaico*** 29,5x32,5 ④

MOSAICO ANTICATO



Roma Statuario Macromosaico Anticato 30x30 ⑤



Roma Calacatta Macromosaico Anticato 30x30 ⑤

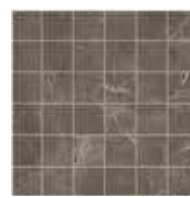

Roma Imperiale Macromosaico Anticato 30x30 ⑤



Roma Travertino Macromosaico Anticato 30x30 ⑤



Roma Pietra Macromosaico Anticato 30x30 ⑤

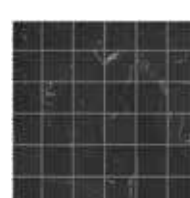

Roma Grafite Macromosaico Anticato 30x30 ⑤



Roma Statuario Micromosaico Anticato* 30x30 ⑤



Roma Calacatta Micromosaico Anticato* 30x30 ⑤



Roma Imperiale Micromosaico Anticato* 30x30 ⑤



Roma Travertino Micromosaico Anticato* 30x30 ⑤



Roma Pietra Micromosaico Anticato* 30x30 ⑤

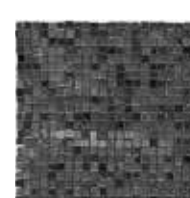

Roma Grafite Micromosaico Anticato* 30x30 ⑤



Roma Brick Statuario Mosaico Anticato** 30x30 ⑤



Roma Brick Calacatta Mosaico Anticato** 30x30 ⑤



Roma Brick Imperiale Mosaico Anticato** 30x30 ⑤



Roma Brick Travertino Mosaico Anticato** 30x30 ⑤



Roma Brick Pietra Mosaico Anticato** 30x30 ⑤



Roma Brick Grafite Mosaico Anticato** 30x30 ⑤

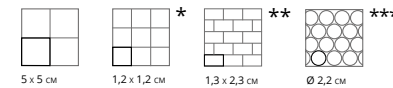

	Unità di vendita Sales unit	MQ./Box	PZ./Box	Kg/Box	Box/PL
①	1 Box	-	1	8,00	-
②	1 Box	-	2 MIX	3,20	-
③	1 Box	-	4	3,20	-
④	1 Box	0,575	6	9,90	72
⑤	1 Box	0,540	6	10,20	60



	Unità di vendita Sales unit	MQ./Box	PZ./Box	Kg/Box	Box/PL
①	1 Box	ML 6,40	8	8,24	-
②	1 Box	ML 4,80	8	6,70	-
③	1 Box	-	8	-	-
④	1 Box	-	2	-	-

TRIMS

ROMA	STATUARIO	GRAFITE	CALACATTA	PIETRA	IMPERIALE	TRAVERTINO
 Battiscopa 7,2x80 RT 3"x31 ^{1/2} "	 Matt ①	 Matt ①	 Matt ①	 Matt ①	 Matt ①	 Matt ①
 Battiscopa 7,2x60 RT 3"x23 ^{5/8} "	 Matt ②	 Matt ②	 Matt ②	 Matt ②	 Matt ②	 Matt ②
 Battiscopa Sagomato DX 7,2x30 RT 3"x11 ^{3/4} "	 Matt ③	 Matt ③	 Matt ③	 Matt ③	 Matt ③	 Matt ③
 Battiscopa Sagomato SX 7,2x30 RT 3"x11 ^{3/4} "	 Matt ③	 Matt ③	 Matt ③	 Matt ③	 Matt ③	 Matt ③
 Scalino 33x80 RT 13"x31 ^{1/2} "	 Matt ④	 Matt ④	 Matt ④	 Matt ④	 Matt ④	 Matt ④
 Scalino 33x60 RT 13"x23 ^{5/8} "	 Matt ④	 Matt ④	 Matt ④	 Matt ④	 Matt ④	 Matt ④
 Scalino Angolare 33x33 RT 13"x13"	 Matt ④	 Matt ④	 Matt ④	 Matt ④	 Matt ④	 Matt ④





Roma Statuario 50x120 RT

V3
①



Roma Filo Statuario 50x120 RT

V3
②



Roma Calacatta 50x120 RT

V3
①



Roma Filo Calacatta 50x120 RT

V3
②



Roma Imperiale 50x120 RT

V2
①



Roma Filo Imperiale 50x120 RT

V2
②



Roma Pietra 50x120 RT

V2
①



Roma Filo Pietra 50x120 RT

V2
②

AVVERTENZE PER LA POSA IN OPERA DEGLI ARTICOLI FILO: posare il prodotto facendo combaciare i movimenti tridimensionali fra una piastrella e l'altra. Le frecce sul retro non sono indicative del verso di posa.

N.B. FOR ON-SITE LAYING OF THE ITEMS FILO: make sure the three-dimensional patterns of the tiles match. The arrows on the back do not indicate the laying direction.

AVERTISSEMENTS POUR LA POSE DES ARTICLES FILO: poser le produit en faisant coïncider les mouvements tridimensionnels entre un carreau et l'autre. Les flèches situées à l'arrière n'indiquent pas l'orientation de la pose.

HINWEIS FÜR DIE VERLEGUNG DER ARTIKEL FILO: Achten Sie bei der Verlegung darauf, dass die dreidimensionalen Bewegungen zwischen den Fliesen jeweils zusammenpassen. Die Pfeile auf der Rückseite geben keine Hinweise auf die Verlegerichtung.

ADVERTENCIAS PARA LA COLOCACIÓN DE LOS ARTÍCULOS FILO: colocar el producto de manera que coincidan los movimientos tridimensionales entre un azulejo y otro. Las flechas de la parte posterior no indican la dirección de colocación.

ИНСТРУКЦИИ ПО УКЛАДКЕ ПЛИТКИ FILO: расположите плитки таким образом, чтобы трехмерные мотивы на каждой из них соответствовали друг другу. Стрелки на обратной стороне не указывают на направление укладки.

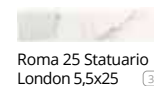

Roma 25 Statuario London 5,5x25 ③

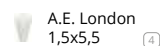

A.E. London 1,5x5,5 ④

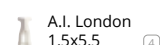

A.I. London 1,5x5,5 ④

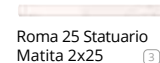

Roma 25 Statuario Matita 2x25 ③

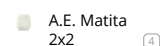

A.E. Matita 2x2 ④

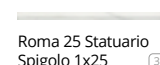

Roma 25 Statuario Spigolo 1x25 ③

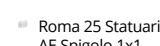

Roma 25 Statuario AE Spigolo 1x1 ④

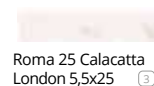

Roma 25 Calacatta London 5,5x25 ③

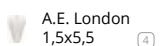

A.E. London 1,5x5,5 ④

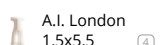

A.I. London 1,5x5,5 ④

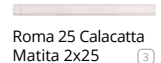

Roma 25 Calacatta Matita 2x25 ③

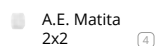

A.E. Matita 2x2 ④



Roma 25 Calacatta Spigolo 1x25 ③

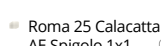

Roma 25 Calacatta AE Spigolo 1x1 ④

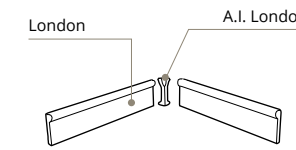
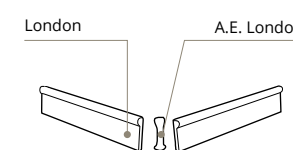

Roma 25 Imperiale Spigolo 1x25 ③

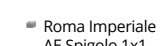

Roma Imperiale AE Spigolo 1x1 ④



Roma 25 Travertino Spigolo 1x25 ③

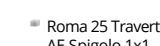

Roma 25 Travertino AE Spigolo 1x1 ④

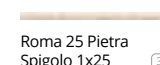

Roma 25 Pietra Spigolo 1x25 ③

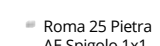

Roma 25 Pietra AE Spigolo 1x1 ④

	Unità di vendita Sales unit	MQ./Box	PZ./Box	Kg/Box	Box/PL
①	1 Box	1,800	3	31,50	30
②	1 Box	1,800	3	31,80	30
③	1 Box	-	5	-	-
④	1 Box	-	4	-	-



Wall: Roma Calacatta & Fold Calacatta - Floor: Roma Calacatta Micromosaico Anticato



Roma Statuario 25x75 V3 ①

Roma 25 Statuario Spigolo 1x25 ③

Roma 25 Statuario AE Spigolo 1x1 ④



Roma Calacatta 25x75 V3 ①

Roma 25 Calacatta Spigolo 1x25 ③

Roma 25 Calacatta AE Spigolo 1x1 ④



Roma Imperiale 25x75 V2 ①

Roma 25 Imperiale Spigolo 1x25 ③

Roma Imperiale AE Spigolo 1x1 ④



Roma Travertino 25x75 V2 ①

Roma 25 Travertino Spigolo 1x25 ③

Roma 25 Travertino AE Spigolo 1x1 ④



Roma Pietra 25x75 V2 ①

Roma 25 Pietra Spigolo 1x25 ③

Roma 25 Pietra AE Spigolo 1x1 ④



Roma Filo Statuario 25x75 V3 ②



Roma Filo Calacatta 25x75 V3 ②



Roma Filo Imperiale 25x75 V2 ②



Roma Filo Travertino 25x75 V2 ②



Roma Filo Pietra 25x75 V2 ②

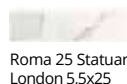

Roma 25 Statuario London 5,5x25 ③

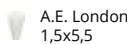

A.E. London 1,5x5,5 ④

Roma 25 Statuario Raccordo 2x25 ③

Roma 25 Calacatta Raccordo 2x25 ③

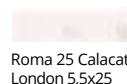

Roma 25 Calacatta London 5,5x25 ③

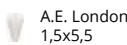

A.E. London 1,5x5,5 ④

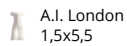

A.I. London 1,5x5,5 ④

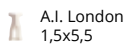

A.I. London 1,5x5,5 ④

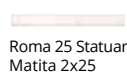

Roma 25 Statuario Matita 2x25 ③

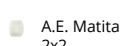

A.E. Matita 2x2 ④

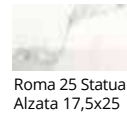

Roma 25 Statuario Alzata 17,5x25 ④

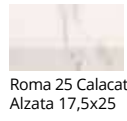

Roma 25 Calacatta Alzata 17,5x25 ④

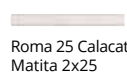

Roma 25 Calacatta Matita 2x25 ③

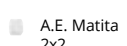

A.E. Matita 2x2 ④



Roma 25 Statuario A.E. Alzata 2x17,5 ③



Roma 25 Calacatta A.E. Alzata 2x17,5 ③



Roma 25 Statuario A.I. Alzata 2x17,5 ③



Roma 25 Calacatta A.I. Alzata 2x17,5 ③



Roma Classic Statuario Inserto 25x75 ⑤



Roma Classic Statuario Listello 8x25 ⑥



Roma Classic Calacatta Inserto 25x75 ⑤



Roma Classic Calacatta Listello 8x25 ⑥



Roma Classic Pietra Inserto 25x75 ⑤



Roma Classic Pietra Listello 8x25 ⑥



Roma Greca Statuario Listello 8x25 ⑥



Roma Greca Calacatta Listello 8x25 ⑥



Roma Greca Pietra Listello 8x25 ⑥



Roma Raku Listello 6x25 ⑥

MOSAICO PASTA BIANCA
Spessore 8,5 mm - Thickness 8,5 mm

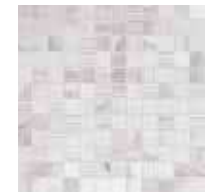

Roma Statuario Mosaico 30,5x30,5* ⑦

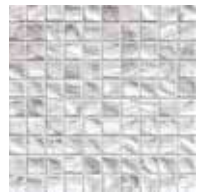

Roma Natura Statuario Mosaico 30,5x30,5** ⑧



Roma Calacatta Mosaico 30,5x30,5* ⑦



Roma Natura Calacatta Mosaico 30,5x30,5** ⑧

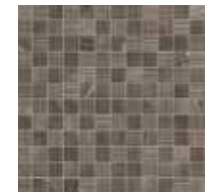

Roma Imperiale Mosaico 30,5x30,5* ⑦

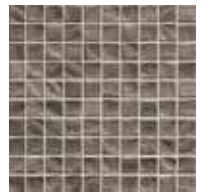

Roma Natura Imperiale Mosaico 30,5x30,5** ⑧



Roma Travertino Mosaico 30,5x30,5* ⑦



Roma Natura Travertino Mosaico 30,5x30,5** ⑧



Roma Pietra Mosaico 30,5x30,5* ⑦



Roma Natura Pietra Mosaico 30,5x30,5** ⑧



2,3 x 2,3 cm *



2,8 x 2,8 cm **

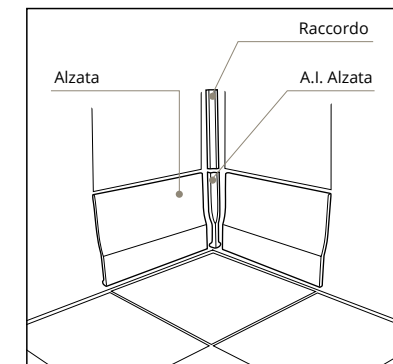
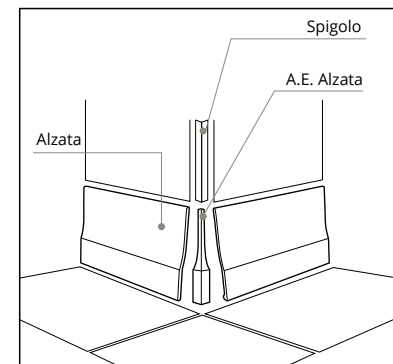
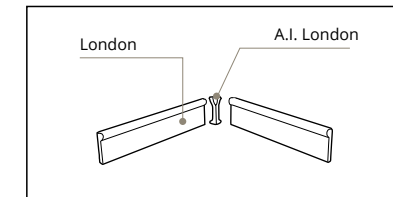
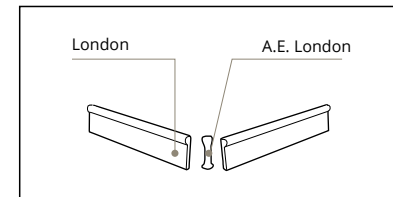

	Unità di vendita Sales unit	MQ./Box	PZ./Box	Kg/Box	Box/PL
①	1 Box	1,500	8	22,40	42
②	1 Box	1,3125	7	19,95	42
③	1 Box	-	5	-	-
④	1 Box	-	4	-	-
⑤	1 Box	-	4	12,10	-
⑥	1 Box	-	5	1,65	-
⑦	1 Box	0,558	6	8,20	84
⑧	1 Box	0,558	6	8,20	60

WALIPEC
Classification WallPEC
Seul le site du CSTB fait foi, pour vérifier les classements indiqués, merci de consulter le site <https://evaluation.cstb.fr/>

Gres Porcellanato - Standard ISO 13006 (EN 14411) Annex G Group BIa, Ev ≤ 0,5%

Porcelain. / Grès cerame. / Feinsteinzeug. / Gres porcelánico. / Керамогранит.

CARATTERISTICHE TECNICHE TECHNICAL SPECIFICATIONS CARACTERISTIQUES TECHNIQUES TECHNISCHE EIGENSCHAFTEN CARACTERÍSTICAS TÉCNICAS ТЕХНИЧЕСКИЕ ХАРАКТЕРИСТИКИ		NORME STANDARDS NORMES NORMEN NORMAS НОРМЫ	VALORE PRESCRITTO VALUES REQUIRED VALEUR PRESCRITE NORMVORGABE VALOR PRESCRITO ЗАДАННОЕ ЗНАЧЕНИЕ EN 14411 - ISO 13006 BIa (UGL e GL)	FAP - VALORE MEDIO* AVERAGE RATING VALEUR MOYENNE DURCHSCHNITTSWERT VALOR MEDIO СРЕДНЕЕ ЗНАЧЕНИЕ BIa UGL		
			NON RETTIFICATO - NOT RECTIFIED	RETTIFICATO - RECTIFIED	MATT	
DIMENSIONI SIZES DIMENSIONS GRÖSSEN DIMENSIONES РАЗМЕРЫ		Lunghezza e larghezza Length and width / Dimensions des côtés / Seitenlänge / Largo y ancho / Длина и ширина	± 0,6%, max 2 mm	± 0,3%, max 1 mm	Conforme In accordance	
		Spessore Thickness / Epaisseur / Stärke / Espesor / Толщина	± 5%, max 0,5 mm	± 5%, max 0,5 mm	Conforme In accordance	
		Ortogonalità ** Wedging / Orthogonalité / Rechtwinkligkeit / Ortogonalidad / Ортогональность	± 0,5%, max 2 mm	± 0,3%, max 1,5 mm	Conforme In accordance	
		Rettilinearità degli spigoli Straightness of the edges / Equerrage des angles / Kantengeradheit / Rectilinearidad de las aristas / Прямолинейность углов	± 0,5%, max 1,5 mm	± 0,3%, max 0,8 mm	Conforme In accordance	
		Planarità Flatness / Planéité / Oberflächenqualität / Planicidad / Плоскостность	± 0,5%, max 2 mm	± 0,4%, max 1,8 mm	Conforme In accordance	
STRUTTURA STRUCTURE STRUCTURE STRUKTUR ESTRUCTURA СТРУКТУРА		Assorbimento d'acqua - valore medio % Water absorption - average value % / Absorption d'eau - valeur moyenne % / Wasseraufnahme - Durchschnittswert % / Absorción de agua - valor medio % / Водопоглощение Среднее значение %	ISO 10545-3 ASTM C373	≤ 0,5%	Conforme In accordance	
		Sforzo di rottura Breaking strength / Force de rupture / Bruchlast / Esfuerzo di ruptura / Усилие на излом	ISO 10545-4	S ≥ 1300 N	S ≥ 2000 N	
		Resistenza alla flessione Bending strength / Résistance à la flexion / Biegefestigkeit / Resistencia a la flexión Прочность при изгибе	ISO 10545-4	R ≥ 35 N/mm ²		Conforme In accordance
		Abrasion profonda Deep abrasion / Abrasion profonde / Tiefenabrieb / Abrasión profunda / Глубокое истирание	ISO 10545-6	≤ 175mm ³	≤ 140mm ³	
SBALZI TERMICI THERMAL SHOCK ECARTS DE TEMPERATURE TEMPERATURWECHSEL CHOQUES TÉRMICOS ТЕМПЕРАТУРНЫЕ ПЕРЕПАДЫ		Coefficiente di dilatazione termica lineare Coefficient of thermal linear expansion / Coefficient de dilatation thermique linear / Wärmeausdehnungskoeffizient / Coeficiente de dilatación termica linear / Коэффициент теплового линейного расширения	ISO 10545-8	Valore dichiarato Declared Value / Valeur déclarée / Angegebener Wert / Valor declarado / Объявленная ценность	≤ 7 МК ⁻¹	
		Resistenza agli sbalzi termici Thermal shock resistance / Resistance aux variations thermiques / Temperaturwechselbeständigkeit / Resistencia a las diferencias de temperatura / Сопротивление температурным перепадам	ISO 10545-9	Resistente Resistant		Resistente Resistant
SICUREZZA SAFETY SÉCURITÉ SICHERHEIT SEGURIDAD БЕЗОПАСНОСТЬ		Coefficiente di attrito dinamico Dynamic friction coefficient / Coefficient de frottement dynamique / Dynamischer Reibungskoeffizient / Coeficiente de fricción dinámico / Динамический коэффициент трения	DCOF BOT 3000	Slip resistant ≥ 0,42	Conforme In accordance	
		Coefficiente di attrito dinamico Dynamic friction coefficient / Coefficient de frottement dynamique / Dynamischer Reibungskoeffizient / Coeficiente de fricción dinámico / Динамический коэффициент трения	DIN 51130	In funzione dell'ambiente o della zona di lavoro. According to the space or the working area / Selon le lieu concerné ou la zone de travail / Je nach Raum oder Arbeitszone / Según el ambiente o de la zona de trabajo / В зависимости от среды или рабочей зоны	R9	
		Classificazione antiscivolo Non-slip classification / Classification antiderapant / Bewertungsgruppe trittsicherheit / Clasificación antideslizante / Классификация противоскольжения	DIN 51097	In funzione delle zone bagnate soggette a calpestio a piedi nudi. According to the wet area to be stepped on barefoot / Selon le type de surface mouillée parcourue pieds nus. / Je nach Nassbereich die barfuß zu betreten sind / Según de la zona mojada que se pisa con los pies desnudos / С учётом увлажняемых зон, предназначенных для ходьбы босиком		
RESISTENZA CHIMICA CHEMICAL RESISTANCE RÉSISTANCE AUX ATTAQUES CHIMIQUES CHEMIKALIENFESTIGKEIT RESISTENCIA A LOS PRODUCTOS QUÍMICOS ХИМИЧЕСКАЯ СТОЙКОСТЬ		Resistenza ai prodotti chimici di uso domestico e agli additivi per piscina Resistance to household chemicals and swimming pool salts / Résistance aux produits chimiques à usage domestique et aux adjuvants pour piscines / Beständigkeit gegen Haushaltchemikalien und Badewasserzusätze / Resistencia a los productos químicos de uso domestico o productos para la piscina / Сопротивляемость химическим средствам домашнего применения и добавкам для бассейна.	ISO 10545-13	MINIMUM B	Conforme In accordance	
		Resistenza a basse concentrazioni di acidi ed alcali Resistance to low concentrations of acids and alkalis / Résistance aux acides et aux alcalis à basse concentration / Beständigkeit gegen niedrigkonzentrierte Säuren und Laugen / Resistencia a concentración baja de ácidos y álcali / Сопротивляемость кислотам и щелочам низкой концентрации		Secondo la classificazione indicata dal fabbricante. According to classification indicated by the manufacturer / Second la classification indiquée par le fabricant / Je nach der angegebenen Fabrikantenbewertung / Según la clasificación indicada del fabricante / Согласно классификации, указанной производителем.		LB Min.
		Resistenza alle macchie Stain resistance / Résistance aux taches / Baständigkeit gegen Fleckenbildung / Resistencia a las manchas / Стойкость к загрязнению	ISO 10545-14	UGL: Metodo di prova disponibile / Test method available / Méthode d'essai disponible / Verfügbare Prüfmethode / Método de prueba disponible / Доступный метод испытания GL: Minimum 3		5

Wall Tiles - Standard ISO 13006 (EN 14411) Annex L Group BIII, Ev > 10%

Pasta Bianca. / White body. / Weißscherbiger. / Pâte blanche. / Pasta blanca. / Белой глины.

CARATTERISTICHE TECNICHE TECHNICAL SPECIFICATIONS CARACTERISTIQUES TECHNIQUES TECHNISCHE EIGENSCHAFTEN CARACTERÍSTICAS TÉCNICAS ТЕХНИЧЕСКИЕ ХАРАКТЕРИСТИКИ		NORME STANDARDS NORMES NORMEN NORMAS НОРМЫ	VALORE PRESCRITTO VALUES REQUIRED VALEUR PRESCRITE NORMVORGABE VALOR PRESCRITO ЗАДАННОЕ ЗНАЧЕНИЕ EN 14411 - ISO 13006 BIII (GL)	VALORE MEDIO FAP* AVERAGE FAP RATING VALEUR MOYENNE FAP DURCHSCHNITTSWERT FAP VALOR MEDIO FAP СРЕДНЕЕ ЗНАЧЕНИЕ FAP BIII (GL)		
			NON RETTIFICATO - NOT RECTIFIED	RETTIFICATO - RECTIFIED	TUTTI I FORMATI - ALL SIZES	
DIMENSIONI SIZES DIMENSIONS GRÖSSEN DIMENSIONES РАЗМЕРЫ		Lunghezza e larghezza Length and width / Dimensions des côtés / Seitenlänge / Largo y ancho / Длина и ширина	± 0,6%, max 2 mm	± 0,3%, max 1 mm	Conforme In accordance	
		Spessore Thickness / Epaisseur / Stärke / Espesor / Толщина	± 10%, max 0,5 mm	± 10%, max 0,5 mm	Conforme In accordance	
		Ortogonalità ** Wedging / Orthogonalité / Rechtwinkligkeit / Ortogonalidad / Ортогональность	± 0,5%, max 2 mm	± 0,3%, max 1,5 mm	Conforme In accordance	
		Rettilinearità degli spigoli Straightness of the edges / Equerrage des angles / Kantengeradheit / Rectilinearidad de las aristas / Прямолинейность углов	± 0,5%, max 1,5 mm	± 0,3%, max 0,8 mm	Conforme In accordance	
		Planarità Flatness / Planéité / Oberflächenqualität / Planicidad / Плоскостность	± 0,5%, max 2 mm	± 0,4%, max 1,8 mm	Conforme In accordance	
STRUTTURA STRUCTURE STRUCTURE STRUKTUR ESTRUCTURA СТРУКТУРА		Assorbimento d'acqua - valore medio % Water absorption - average value % / Absorption d'eau - valeur moyenne % / Wasseraufnahme - Durchschnittswert % / Absorción de agua - valor medio % / Водопоглощение Среднее значение %	ISO 10545-3	> 10%	Conforme In accordance	
		Sforzo di rottura Breaking strength / Force de rupture / Bruchlast / Esfuerzo di ruptura / Усилие на излом	ISO 10545-4	S ≥ 600 N		Conforme In accordance
		Resistenza alla flessione Bending strength / Résistance à la flexion / Biegefestigkeit / Resistencia a la flexión Прочность при изгибе	ISO 10545-4	R ≥ 12 N / mm ²		Conforme In accordance
		Aspetto della superficie % senza difetti nel lotto di prova Quality of the surface Faultless % within the sample lot / Qualité de la surface % sans défauts dans le lot d'essai / Oberflächenqualität % an fehlerfreien Fliesen im Prüfbett / Aspecto de la superficie % sin defectos en el lote de prueba Вид поверхности % без брака в пробной партии		≥ 95%		Conforme In accordance
SBALZI TERMICI THERMAL SHOCK ECARTS DE TEMPERATURE TEMPERATURWECHSEL CHOQUES TÉRMICOS ТЕМПЕРАТУРНЫЕ ПЕРЕПАДЫ		Resistenza agli sbalzi termici Thermal shock resistance / Resistance aux variations thermiques / Temperaturwechselbeständigkeit / Resistencia a las diferencias de temperatura / Сопротивление температурным перепадам	ISO 10545-9	Conforme In accordance	Conforme In accordance	
		Resistenza al cavillo Crazing resistance / Résistance aux craquelures / Haarriß-Beständigkeit / Resistencia al cuarteado / Сопротивляемость образованию кракелюров	ISO 10545-11	Conforme In accordance		Conforme In accordance
		Resistenza ai prodotti chimici di uso domestico e agli additivi per piscina Resistance to household chemicals and swimming pool salts / Résistance aux produits chimiques à usage domestique et aux adjuvants pour piscines / Beständigkeit gegen Haushaltchemikalien und Badewasserzusätze / Resistencia a los productos químicos de uso domestico o productos para la piscina / Сопротивляемость химическим средствам домашнего применения и добавкам для бассейна.	ISO 10545-13	B Min.		Conforme In accordance
SUPERFICIE SURFACE OBERFLÄCHE SUPERFICIE ПОВЕРХНОСТЬ		Resistenza a basse concentrazioni di acidi ed alcali Resistance to low concentrations of acids and alkalis / Résistance aux acides et aux alcalis à basse concentration / Beständigkeit gegen niedrigkonzentrierte Säuren und Laugen / Resistencia a concentración baja de ácidos y álcali / Сопротивляемость кислотам и щелочам низкой концентрации		Metodo di prova disponibile Test method available / Méthode d'essai disponible / Verfügbare Prüfmethode / Método de prueba disponible / Доступный метод испытания	LB Min.	
		Resistenza alle macchie Stain resistance / Résistance aux taches / Baständigkeit gegen Fleckenbildung / Resistencia a las manchas / Стойкость к загрязнению	ISO 10545-14	MINIMUM CLASS 3		5

* Valore medio dei test condotti negli ultimi 24 mesi. Average rating of tests conducted during the last 24 months. Durchschnittswert der in den letzten 24 Monaten durchgeführten Tests. Valeur moyenne des essais menés au cours des 24 derniers mois. Valor medio de las pruebas llevadas a cabo en los últimos 24 meses. Среднее значение испытаний, проведенных в течение последних 24 месяцев.

** Per piastrelle rettangolari, che abbiano il lato maggiore L ≥ 60 cm, e rapporto tra i lati ≥ 3, la misurazione della ortogonalità deve venire condotta solo sul lato corto. For oblong tiles with L ≥ 60 cm and ratio length/width L/W ≥ 3, measurement of rectangularity only on short edges

* Valore medio dei test condotti negli ultimi 24 mesi. Average rating of tests conducted during the last 24 months. Durchschnittswert der in den letzten 24 Monaten durchgeführten Tests. Valeur moyenne des essais menés au cours des 24 derniers mois. Valor medio de las pruebas llevadas a cabo en los últimos 24 meses. Среднее значение испытаний, проведенных в течение последних 24 месяцев.

** Per piastrelle rettangolari, che abbiano il lato maggiore L ≥ 60 cm, e rapporto tra i lati ≥ 3, la misurazione della ortogonalità deve venire condotta solo sul lato corto. For oblong tiles with L ≥ 60 cm and ratio length/width L/W ≥ 3, measurement of rectangularity only on short edges

VSHADE

La classificazione V-Shade indica il livello di stonizzazione del prodotto, classificato da V0 a V4.

The V-Shade classification indicates the level of shading of the product, ranked from V0 to V4.

V0

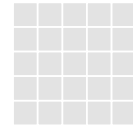

Nessuna
None

Aucune
Keine
Ninguna
нулевой

V1



Leggera
Light

Légère
Leicht
Ligera
Низкий

V2

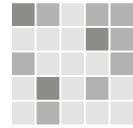

Moderata
Moderate

Modérée
Mäßig
Moderada
Средний

V3



Alta
High

Élevée
Hoch
Alta
Значительный

V4

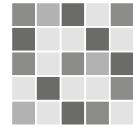

Forte
Very High

Forte
Stark
Fuerte
Высокий

Le classement V-shade indique le niveau de mouvement chromatique au sein d'un produit. Il va de V0 à V4.

Die V-Shade-Einstufung gibt die Farbunterschiede zwischen Fliesen einer Kollektion an, die Kategorien sind V0 bis V4.

La clasificación V-Shade indica el nivel de destonación del producto, clasificado de V0 a V4.

Согласно классификации V-Shade, указывающей на уровень цветовой неоднородности изделия, нашей плитке были присвоены значения от V0 до V4.

Per tutte le istruzioni di posa, pulizia e smaltimento, consultare il sito www.fapceramiche.com alla sezione Faq.
For full instructions on installation, cleaning and disposal, consult the FAQ section on the www.fapceramiche.com.
Pour toutes les instructions de pose, de nettoyage et d'élimination, consultez le site www.fapceramiche.com à la section FAQ.
Für alle Anweisungen für das Verlegen, Reinigen und Entsorgen besuchen Sie bitte die Website www.fapceramiche.com im Bereich FAQ.
Puede consultar todas las instrucciones de colocación, limpieza y eliminación en la sección de preguntas frecuentes (FAQ) del sitio web www.fapceramiche.com.
Для любой информации по укладке, очистке и утилизации посетите страницу Частых Вопросов на сайте www.fapceramiche.com.

I colori e le caratteristiche estetiche dei materiali illustrati nel presente catalogo sono da ritenersi puramente indicativi.
Colours and optical features of the materials illustrated in this catalogue are to be regarded as mere indications.
Die Farben und die ästhetischen Eigenschaften der in diesem Katalog abgebildeten Produkte sind als reine Richtwerte zu betrachten.
Les coloris et les caractéristiques esthétiques des références illustrées dans le catalogue sont donnés à titre purement indicatif.
Los colores y las características ópticas de los materiales ilustrados en este catalogo deben ser mirados como indicaciones meras.
Цвета и эстетические характеристики описанных в настоящем каталоге материалов являются только ориентировочными.

Fap ceramiche si riserva di apportare modifiche e/o eliminare senza preavviso i prodotti declinando ogni responsabilità per danni diretti o indiretti derivanti da eventuali modifiche.
Fap ceramiche can change the indicated products without notice declining any responsibility for direct or indirect damage that depend on these changes.
Fap ceramiche se réserve le droit de modifier sans préavis les produits indiqués et décline toute responsabilité pour dommages directs ou indirects dus à éventuelles modifications.
Fap Ceramiche se reserva la facultad de modificar los productos sin preaviso, declinando cualquier responsabilidad por daños directos o indirectos que dependan de estos cambios.
Fap ceramiche kann die genannten Produkten ändern ohne Voranmeldung und lehnt dabei jegliche Verantwortung für die davon abhängenden direkten oder indirekten Schäden ab.
Компания "Fap ceramiche" сохраняет за собой право на внесение изменений в продукцию без предварительного уведомления, снимая с себя всякую ответственность за связанный с этими изменениями прямой или не прямой ущерб.

Fap ceramiche - 5th edition October 2025 - 1st edition September 2015

È vietata la riproduzione anche parziale dell'opera in tutte le sue forme.
Reproduction of this printed catalogue, even partially, is prohibited.



17889-1
Certified by DNV





Via Ghiarola Nuova, 44 - 41042 Fiorano Modenese (MO) Italy
tel. +39 0536 837511 - fax +39 0536 837532 - fax estero +39 0536 837542
www.fapceramiche.com - info@fapceramiche.com

